



# Digital Level User Manual



## Introduction

Thanks for your support. SDL-2 is an economic type of digital automatic level featured in easy operation, quick & accurate reading. With the newest digital system, SDL-2 will be your right-hand assistant.

Please keep User Manual properly and read it carefully for a good use of the instrument.

### Notice:

1. For a good state, the instrument should be checked and adjusted by responsible person esp. after long time storage or transportation. For further information, please refer to Page 16 **3. *Checking and Adjustment.***
2. Before Measuring, please conform instrument running properly.
3. Do not storage the instrument at high temperature nor set it up under strong sunlight for a long time in case of photosensor heating up and affect the accuracy of the instrument.
4. Please use specialized staffs when operate with digital measuring mode. Make sure staff surface clean without scratching & stain and pull out staff in proper position. When you operate with Optical

measuring, you can use the back side of bar staff or equivalent.

5. For a better use and daily adjustment, we highly suggests you to equip at least two pieces of our standard bar staff.
6. When operating digital mode, avoid direct sunlight passing through objective lens and eyepiece which may cause interference. If image of staff is too dark and background is too light, it may cause interference the same.
7. During transportation, please keep instrument stay in case. If you are going to move the instrument, put it into case firstly.
8. After working, please clean the instrument and put it into cases.
9. Surface, buttons, screen etc is suitable cleaned by soft clean clothes, Optical parts is better to use lens paper. Do not touch lens with fingers.
10. Storage the instrument in a try room with constant temperature.
11. If the instrument need repair. Make sure it is checked & repaired by technicians with well known of instrument construction or send it back to a professional dealer.

## **Warning**

1. **Never observe the sun through telescope system.**

- 2. Be carefully when working around high voltage facilities.**
- 3. Do not handle Staff in thunderstorms.**
- 4. Humid condition is harmful to battery.**
- 5. Keep distance from flammable and explosive materials.**
- 6. Survey should be operated in safety area and please obey local safety rules & traffic rules.**
- 7. Prevent battery from high temperature.**

# Index

1. Important Parts and Operation	
Manual.....	5
1.1 Important Parts.....	5
1.2 Buttons.....	6
1.3 Display Screen.....	6
2. Instrument Operation.....	7
2.1 Preparation.....	7
2.1.1 Battery Install.....	7
2.1.2 Instrument setting.....	7
2.2 Sight and Focusing.....	8
2.3 Digital mode.....	9
2.3.1 Digital measurement.....	9
2.3.1.1 Height.....	9
2.3.1.2 Height difference.....	9
2.3.1.3 Inverse staff mode.....	10
2.3.2 SET the instrument.....	10
2.3.3 The rest operation of settings.....	12
2.4 Optical Measurement.....	12
2.4.1 Height measurement.....	12
2.4.2 Height Difference.....	13
2.4.3 Stadia Measurement.....	14
2.4.4 Angle Measurement.....	15
3. Checking and Adjustment.....	16
3.1 Circular Bubble.....	16
3.2 Line of sight.....	17
3.2.1 Optical.....	17
3.2.2 Digital.....	18
3.3 Staff Offset.....	21
3.4 Stadia Err.....	22
3.5 Reset.....	23
4. Fault information.....	24
5. Technical Data.....	25
6. Packing list.....	26

# 1. Important Parts and Operation Manual

## 1.1 Important Parts

1. Objective lens
2. Peep Sight
3. Screen
4. Buttons
5. Seal Plug
6. Eye piece
7. Graduation Pointer
8. Horizontal Graduation Circle
9. Bubble Adjusting Screw
10. Circular Bubble
11. Reflecting Mirror
12. Battery Compartment
13. Battery Set Screws
14. Footscrews
15. Horizontal Tangent Screw
16. Focusing Knob

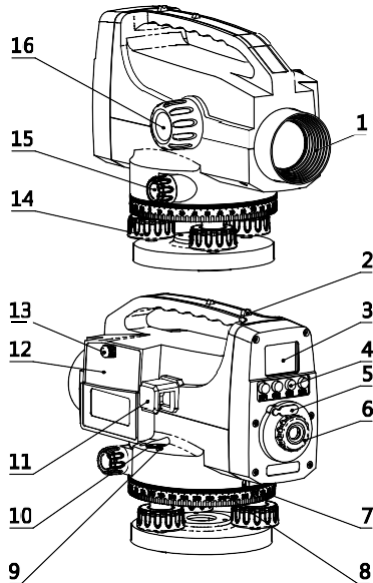

Fig 1

## 1.2 Buttons

Four buttons active functions like below(left side to right side):

(1) Main function: Power / Model / Setting / Measure

(2) Settings function: None / Quit / Confirm / Shift

(3) Input function: None / Quit / Shift / Input

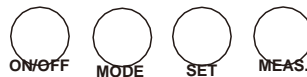
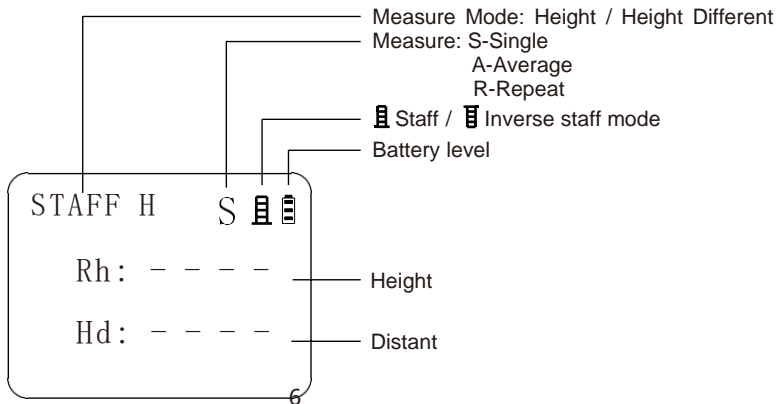

Fig 2

## 1.3 Display Screen





## 2. Instrument Operation

### 2.1 Preparation

#### 2.1.1 Battery Install

Loosen screw and open battery cap(Figure 4). Install four AA batteries as figure 5 shows, lock the cap, and tighten the set screw.

**☞Tips:** When locking the battery compartment, please tighten the screw to ensure seal design works.

#### 2.1.2 Instrument setting

- (1) Extend the tripod legs until top holder is at eye level.
- (2) Tighten screws and stick tripod legs firmly into the grand.
- (3) Set instrument and tighten the centering screw.
- (4) Move bubble to the center of circle by adjusting the footscrews. (figure 6) Adjust A and B screws to move bubble left and right then adjust C screw to move bubble

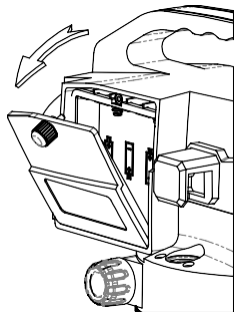

Fig 4

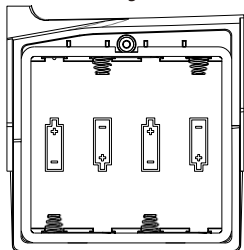

Fig 5

into the centre circle.

## 2.2 Sight and Focusing

- (1) Rotate eyepiece to make the reticle being clear. (figure 7)
- (2) Target the staff through peep sight. Rotate focusing knob to make the staff image being clear. Coincide vertical hair with the middle of the staff. (figure 8)
- (3) Move your eye sight

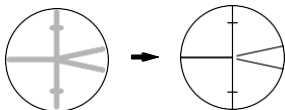

Fig 7

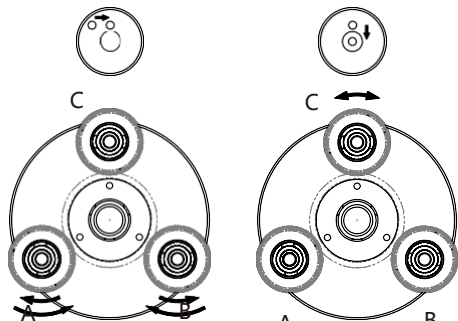

Fig 6

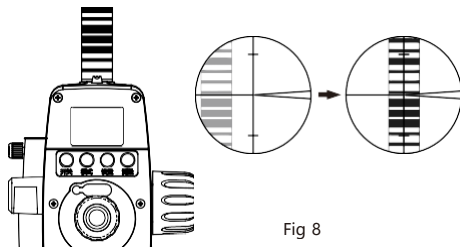

Fig 8

right, left, up and down. If staff image and reticle hair remains still, you can start work.

 **Attention:**

- a) Bar side is for digital mode measurement and ruler side is for optical mode.
- b) Digital measurement only fits our standard bar staff.
- c) Keep staff in a vertical position with the help of bubble level ( you can find this accessory in staff package).

## 2.3 Digital mode

### 2.3.1 Digital measurement.

#### 2.3.1.1 Height

- (1) Press power(ON/OFF) button and wait launching complete.
- (2) Press MODE button, select Staff H.
- (3) After measurement preparation, press MEAS. Button, date will show up in few seconds. (figure 9)  
Height=1.438m Distant=34.39m
- (4) Press and hold power button to power off.

#### 2.3.1.2 Height difference

- (1) Press power (ON/OFF) button and wait launching complete.



Fig 9

(2) Press mode button, select DIFF.

- (3) Meas. BS(Staff A) will show up in screen firstly. Measure the first staff and get data as Height=1.568 Distance=29.36 (figure 9). Press SET button then Meas. FS(Staff B) shows up. Measure the second staff and get data as figure 10. In few seconds, Height difference will be figured out (figure 11). Height difference=0.189m, Height of Staff B=1.379m, Distance to Staff B=29.98

 **Tips: Do not press the button too hard to bring a shaking. It will effect the accuracy of measurement.**

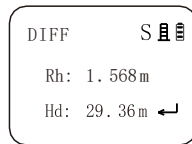

Fig 10

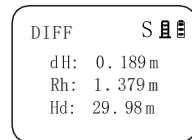



Fig 11

### 2.3.1.3 Inverse staff mode

This mode is for ceiling leveling. Processes is like below:

- (1) Press SET button few times until you see Inverse Staff  , press MEAS. to turn it on.
- (2) Inverse the staff vertically, and up against to the ceiling. Then operate the same with 2.3.1.1 and 2.3.1.2

### 2.3.2 SET the instrument

After startup, press SET button to enter settings mode. SET button

is used as to select and MEAS. Button is used as to confirm.  
MODE button used as to quit.

(1) Measure Mode.

Single --Data is figured out by a single measurement. You can see "S"on screen when this mode is activated.

Mean -- Several times of measurements average out a average data. You can see "A"on screen when this mode is activated.

Rept -- Measure target constantly and stop when you press MEAS button. This mode will show you the data of last measurement. You can see "R"on screen when this mode is activated.

(2) Backlight : On--turn on the backlight

Off--turn off the backlight

(You can also press and holding the SET button to switch between on and off)

(3) Beep: On--turn on the beep device

Off--turn off the beep device

(4) Inverse Staff:

Off-- Measuring upward staff, You can see "  "

- On-- Inverse the staff and measuring. You can see"  "
- (5) Units:  
M- - Metre  
ft - - Foot
- (6) Rounding:  
Minimum reading: 0.001/0.0001m
- (7) Auto Off:  
15min– Instrument will power off after 15 minutes  
without operation.  
Off - - - Instrument keeps running until power off.
- (8) Aver. Times: Data is figured out by 1~9 times measurements.

### 2.3.3 The rest operations of settings

- (1) Press and hold the SET button to turn on/turn off backlight.
- (2) In 3 seconds after Start up you can check Instrument ID number by pressing SET button .

## 2.4 Optical Measurement

### 2.4.1 Height measurement.

- (1) Use the ruler side of the staff, and keep vertical.
- (2) Adjust eyepiece and focusing knob to make reticle and staff

images both clear.

- (3) Read Data as figure 12,  $H=1.165\text{m}$

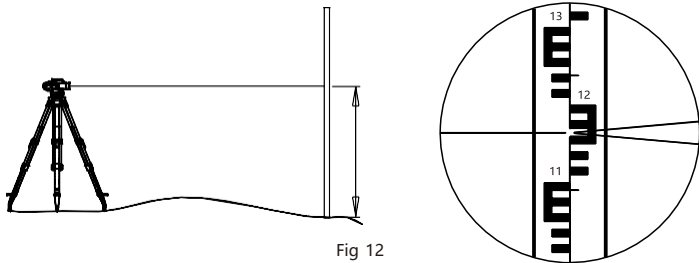

Fig 12

#### 2.4.2 Height Difference

- (1) Set up the instrument at a point approximately halfway between point A and point B.
- (2) Posit the staff vertically at point A, take a reading as “a” (Example  $a=1.735\text{ m}$ )
- (3) Then read the staff at point B and obtain the reading as “b”. (Example  $b=1.224\text{ m}$ )

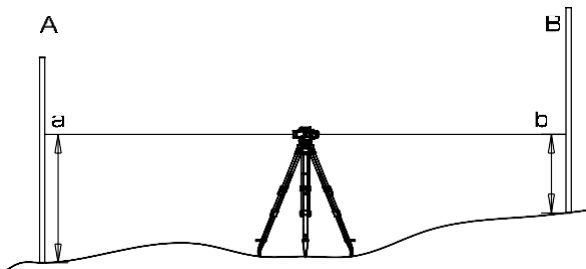

Fig 13

(4) The difference  $a-b$  is the AB height difference “ $h$ ”(Example:  $h=a-b=1.735-1.224=0.511\text{m}$ )

### 2.4.3 Stadia Measurement

(1) Read the staff and count the Difference  $L$  between two stadia lines.

Up Stadia Line: 1.238m

Down Stadia Line: 1.091m

Difference  $L=1.238-1.091=0.147\text{m}$ ,

Distance  $D= 100*L=14.7\text{m}$

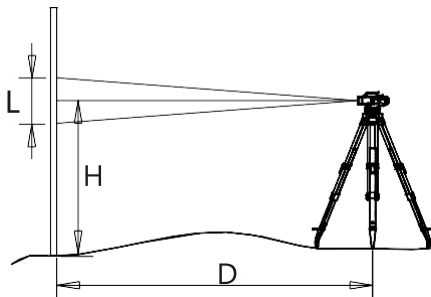
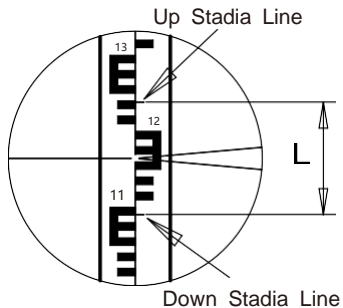

Fig 14

#### 2.4.4 Angle Measurement:

- (1) Direct instrument to staff A and turn Horizontal Circle to "0".
- (2) Point instrument to staff B
- (3) Read off Hz-angle from Horizontal Graduation Circle. Figure 15: Hz=43°

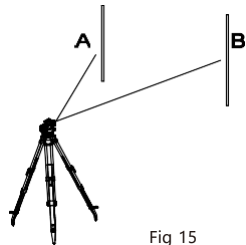

Fig 15

### 3. Checking and Adjustment

Pls check instrument before working. Instrument must be checked and adjusted by responsible person regularly.

#### 3.1 Circular Bubble:

- (1) Center the bubble of the Circular Level precisely by using the Leveling Foot Screws.
- (2) Turn the telescope around  $180^\circ$  (or 200 gon).
- (3) The bubble needs adjustment if it is uncentered.
- (4) Adjust Leveling

Footscrews to move the bubble to the middle place of the offset.

- (5) Adjust the rest half of offset by using Allen key.
- (6) Repeat the above steps until the bubble remains centered when telescope point

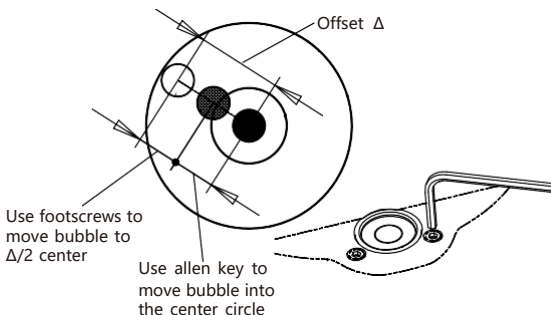

to any direction.

Fig 16

## 3.2 Line of sight

### 3.2.1 Optical

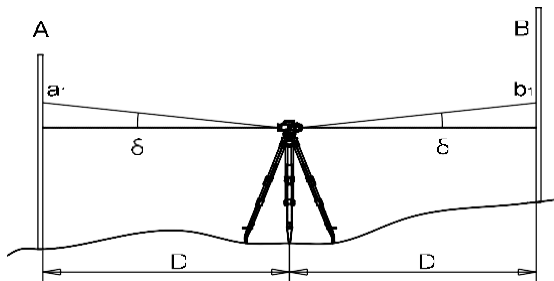

Fig 17

- (1) Set the instrument at a point halfway between point A and B spaced about 30-40m apart. Take readings of staff A and staff B as “a1” and “b1”.(Figure 17) Calculate the real height difference :  $\Delta H = a_1 - b_1$
- (2) Set up the instrument about 1 m away from point A and read staff A and staff B as “a2” and “b2”. (Figure 18)
- (3) Then you can get logical value  $b_2' = a_2 - \Delta H$

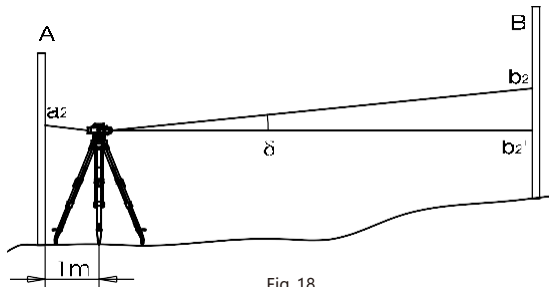

Fig 18

---- $b_2'$  is the height  $b_2$  should be

- (4) When the difference between  $b_2$  and  $b_2'$  is more than 3mm, the line of sight must be adjusted.
- (5) Pull out the seal plug and adjust the adjusting screw until horizontal hair move to reading  $b_2'$ .

### 3.2.2 Digital

- (1) Set staff A and staff B with 45 metres

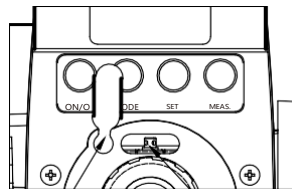

Seal Plug Adjusting

distance, and set Point 1 at 15 metres

Fig 19

screw

and Point 2 at 30 metres as Points where instrument set up.(Figure 20)

👉 To ensure a correct adjustment , distance between those points should be keep in a certain range as  $15 \pm 0.5\text{m}$ .

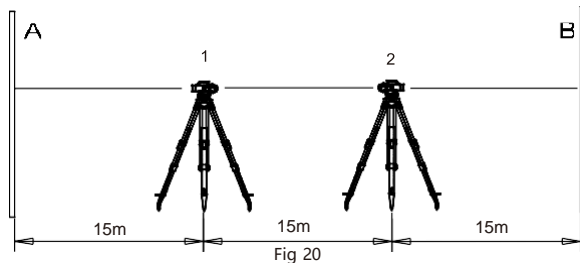

- (2) First set instrument at Point 1. Press and hold Meas. Button and press Power button to enter adjustment mode(Figure 21). Press MEAS. button then SET button to enter Collimation

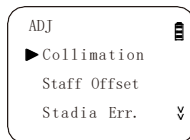

Fig 21

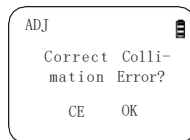

Fig 22

mode as figure 22. (MODE=CE SET=OK)

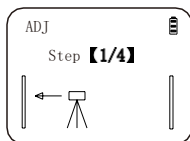

Fig 23

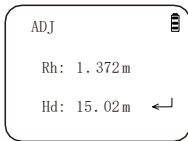

Fig 24

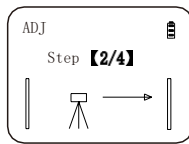

Fig 25

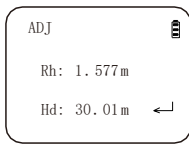

Fig 26

- (3) When you see figure 23, measure Staff A. After data showed up as figure24, press SET to the next step.
- (4) Rotate instrument to point Staff

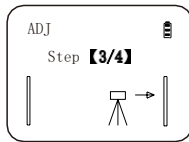

Fig 27

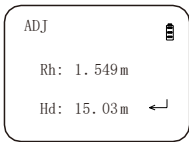

Fig 28

- B and measure it. After data showed up as figure26, press SET to the next step (Figure 27).
- (5) Move instrument to Point 2 and set it properly, measure Staff B. After data showed up as Figure 28, press SET button to the next step (Figure 29).



Fig 29

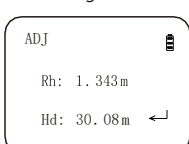

Fig 30

- (6) Then measure Staff A. After data showed up as Figure 30, press SET button to the next step
- (7) Now measurement of those 4 points has been finished. Press SET button to confirm the result.(Figure 31) Then press SET button to save and restart.

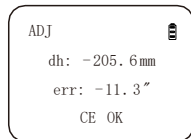

Fig 31

### 3.3 Staff Offset

- (1) When measuring a staff, you may find out that digital mode and optical mode give out difference height. Now you should operate staff off set.

**☞Attention: Before Staff offset, make sure that you have adjusted 3.2.1 optical line of sight and 3.2.2 digital line of sight.**

- (2) Set the staff and instrument properly, read the staff within optical system. Like 1.319m
- (3) Turn staff to the bar side.

**☞Attention: staff should set in hard ground, and when you turning the staff, do not change its height.**

- (4) Press and hold MEAS. button and power button



Fig 32

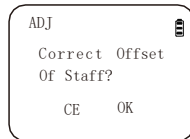

Fig 33

to enter adjusting mode. Press MEAS. button to select “Staff

Offset”(figure 32), press SET button to enter Staff offset(figure 33),

press SET button to confirm.  
 (5) Input the data you get from “(2)”, press SET button to select digit underline place, press MEAS. button to input 0-9 as 1.3190m (figure 34), Input numbers one by one. When “Enter” shows up in screen, (figure 35), press SET button, it will mentioned you to aim the staff.

(6) Measure the staff and get the data as figure 36. Press SET button to get the difference (figure 37). Then press SET to confirm and restart.

### 3.4 Stadia Err.

(1) Set the staff and instrument

properly, and measure the distance between staff and instrument with high-precision rangefinder.



Fig 34



Fig 35

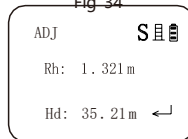

Fig 36

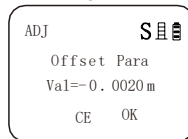

Fig 37



Fig 38

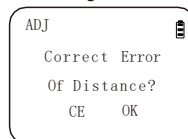

Fig 39

- (2) Press and hold MEAS. and Power Button to enter adjusting mode. Press Meas. to select “Stadia Err”(figure 38), press SET to enter

Stadia Err (figure 39), press SET to confirm.

- (3) Input distance data you get from process (1), press SET button to select digit underline place, press Meas. to input 0-9 (figure 40). Input numbers one by one. When “Enter” shows up in screen, (figure 41), press SET button, it will mentioned you to aim the staff.

- (4) Measure the staff and get the data as figure 42. Press SET button to

get the Stadia Err. (figure 43). Press SET to confirm and restart.

### 3.5 Reset.

Press and hold Meas. and Power Button to enter adjusting mode. Press MEAS button. to select “Reset”(figure 44), press SET to enter reset mode (figure 45), press SET to confirm.

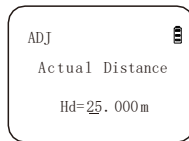

Fig 40

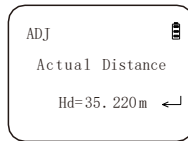

Fig 41

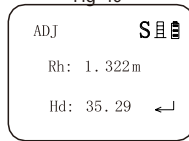
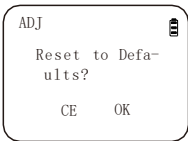

Fig 42



Fig 43



Save and restart.

Fig 44

Fig 45

## 4. Fault information

Fault Information	Reason	Solution
Poor Condition!	Miss the staff	Target the staff and focus staff properly
	Barrier	Remove barrier
	Shaking environment	Wait the shaking stop or select another spot
	Atmosphere disturbance caused by Strong wind or light	Wait a good weather
	Too close to staff	Change measuring distance to 3m at least
	Eye piece received too much light	Cover eye piece when Measuring
	Background light of staff is too strong	Change measuring spot or angle, or wait background light darken
	Staff set in a dark environment	Ensure environment light is higher than 40 lux
	Focusing is adjusted not properly	Focus the staff precisely, make image clear
	A bad sigh condition	No barriers should be existed between the staff and instrument
	Staff image incomplete	Keep surface of staff clear, No scratching No stain
Target too Far	Measuring distance is more than 110m	Keep measuring distance between 3m to 110m

## 5. Technical Data

Accuracy		
Height	1km double run leveling	
	Digital	0.8mm
	Optical	1.5mm
Distance	D≤10m	10mm
	D > 10m	Dx0.2%m
Measuring		
Digital Working Range	3-110m	
Optical Min-Focusing	0.6m	
Measuring time	1-3s*	
Min value (Height)	0.001/0.0001m	
Min value (Distance)	0.01m	
Continuous Working Time	> 20 Hour**	
Continuous Stand-by Time	> 45 Hour**	
Lowest Illumination	40lux	
Telescope System		
Image	Erect	
Magnification	32x	
Aperture	36mm	

Angle of Field of view	1°20'
Stadia Constant	100
Additive Constant	0
Compensator	
Damping	Magnetic
Accuracy	0.5"
Compensation Range	15'
Circleleveling Sensitive	8'/2mm
Circular Graduation	1° or 1gon
LCD Screen Resolution	128x64 pix
Working Temperature	-10—+50°C
Storage Temperature	-40—+70°C
Waterproof	IP54
Battery	AA battery x 4
Instrument Size	245x130x182mm
Weight (battery included)	1.8kg

\* ——— Actual measuring time depend on working environment.

\*\* ——— Continually time will change according to battery capacity.

## 6. Packing list

Instrument:	1 pc
Manual :	1 pc
Allen key:	1pc
Adjusting needle:	1pc
AA battery :	4pcs
Specialized bar staff:	optional
Plumb:	1pc



info@geonin.com  
www.geonin.com

Copyright GEONiN Geo Navigation Instrument Network Co., Ltd

