



**DM-101**



## Preface

Thanks a lot for purchasing our total station!

This manual is your good helper, please read it carefully before using the instrument and keep it safely.

Product affirms:

In order to get the best service from our company, please feedback your instruments' version including number, purchasing date and your suggestions to us after the purchasing of the product.

We will attach great importance to any piece of advice from you,

We will be very concerned about any detail of our products,

We will make great efforts to provide better quality.

Notice: Our Company has the right to upgrade and improve the technical parameters of instruments, which may not be announced in advance .The pictures in the manual are only for reference and kind prevail.

### ● Features:

Rich Feature: Our Total Station is equipped with a wealth of measurement applications including data storage, parameter settings and etc. It's suitable for all kinds of professional measurements.

#### 1. Absolute coded dial

With absolute digital dial, instruments can be measured directly when it powers on. The measured azimuth angle result will not be lost even when the instrument shut off.



## **2. powerful memory management**

Large-capacity EMS memory, easy to manage the file system, serving to add, delete and transfer data

## **3. No prism ranging**

The series Total Station with laser ranging No-Prism is capable of surveying for long distance, fast and precise measurements with various materials and different colors of objects (such as building walls, poles, wires, cliff wall, mountain, mud , stakes, etc.). For those which are hard or impossible to be reached, the application of Prism features can be a good measurement tasks.

## **4. special measurement procedure**

The series total station is equipped with the basic surveying function as well as special measurement procedures, undertaking REM, offset measuring, stakeout, Resection, area measurement and calculation, road design etc. to meet the needs of professional measurement.

## **5. eyepiece changeable**

The instruments' eyepiece can be changed, and equipped with a diagonal eyepiece, serving to observe zenith and high buildings

## **6. An optional laser plumb**

The site features is easy to instruct and set up stations

### **NOTE:**

1. Avoid look directly into the sun with the eyepiece when measuring. Recommended to use solar filter to reduce the impact
2. Avoid extreme temperature when storing equipment and sudden changes in temperature when using the instrument.
3. The instrument should be loaded in box placed in dry and ventilated place and prevented from shock, dust and moisture when it is not in use.
4. In order to get good accuracy, you should leave the instrument in the box if the instrument temperature has large difference between working and storing you may unpack the box and employ the instrument until the instrument reaches the temperature at the working field.
5. If the instrument is not used for a long time, the battery should be unloaded and stored separately and charged once a month to prolong battery life.



6. The instrument should be installed in box when it is transported. Extrusion, collision and violent vibration need to be carefully avoided during the transport process. The soft mat May be placed around the box on the long-distance transportation.
7. It is better to use high quality wooden foot stool to make sure the stability of measurement and improve its accuracy, when setting up the instrument.
8. Only use absorbent cotton or lens paper to wipe the instrument gently if exposed optical device need to be cleaned.
9. Use flannelette or hairbrush to clean the instrument after using. Do not electrify and start up after the device got wet in a rain. Using clean soft cloth to wipe it dry and put it at ventilated place for a period of time to make the instrument fully dry before using or packing.
10. Inspect instrument carefully and comprehensively to ensure its indicators, function, power supply, initial setting and correction parameters meet the requirements before operating.
11. If the function is abnormal, non-professional maintenance persons are not allowed to dismantle the device without authorization in case of any unnecessary damage.
12. The emitted light of the no-prism total station is laser, do not direct to eyes.

#### ● Security Guide

Pay attention to the following safety matters when you use the laser ranging free of prism.

#### **Warning:**

Total station fit out laser level 3R/**III** which is recognized by the logo, which is above: the vertical locking screw saying: "3A laser product ".This product belongs to Class 3R level laser .According to the following standards IEC 60825-1: 2001Class 3R/**III** laser product can reach five times of emission limits of the Class 2/**II**in the wavelength between 400nm-700nm.

#### **Warning :**

Continuous stare into the laser beam is harmful.





**Prevention:**

Do not stare at laser beam or point to others. The reflected beams is the effective signal of the instrument. It's safety to observe by eyepiece.

**Warning:**

When the laser beam is irradiated reflected by prisms, plane mirrors, surface of metal and windows, it's dangerous to look straight into the reflected beams.

**Prevention :**

Don't stare at the reflected beams. When the laser is switched on (distance mode), do not obstruct optical path or stand near the prism. Target at a prism with total station telescope only.

**Warning :**

It's dangerous to use the Class 3R laser device improperly.

**Prevention:**

To avoid injury, each user must carry safety prevention measures and operate the instrument within the safety scope according to standard IEC60825-1: 2001).

The following is the explanation of the main part of the standard:

Class 3R level laser products are used outdoors and in construction (surveying with No-Prism).

A: Only trained and certified persons are allowed to install, adjust and operate the laser equipment.

B: Set up appropriate laser warning sign within the operating field

C: To prevent anyone from looking into the laser beam use an optical instrument to observe.

D: In order to prevent laser damage to persons, the laser beams should be blocked at the end of the working route, and also should be cut off when people work in the restricted area (harmful distance)where laser beams crossing are harmful.

E: The route of the laser beam must set to be higher or lower than the human eye.

F: Properly store and safe keep the laser products when they it is not used, unauthenticated personals are not allowed using it.

G: Do not point laser beams at surfaces such as plane mirror, metal surface, window, especially the surface of plane mirror and concave mirror.

**Harmful Distance** is the maximum distance from the starting point of the laser beams to where people are right safe. The built-in harmful distance of the Class 3R/  laser



is 1000m(3300ft) and the laser intensity will reduce to that of Class 1 products (which does not harm eyes) if people is out of this range.

## CONTENTS

CONTENTS .....	6
1. Name and function of each part .....	10
1. Name .....	10
2. Keys Functions and information display .....	12
2. Preparation before measurement .....	13
1. Unpack and store instrument.....	13
2. Setting up the instrument .....	13
3. About the battery .....	15
4. Reflecting prism .....	16
5. Loading or unloading the base .....	16
6. Adjust telescope objective and aiming target .....	16
7. Input Mode .....	17
7.1 Input characters .....	17
7.2 Delete characters .....	18
8. Point Search .....	19
8.1 Direct search .....	19
8.2 Wildcard search .....	22
3. Q-Survey .....	24
1. Notes in the distance measurement .....	24
2. EDM Setting.....	26
2.1 Set the mode of EDM .....	26
2.2 Atmosphere setting .....	28
2.3 Grid factor setting .....	31
2.4 EDM signal.....	32
3. Start measurement .....	34
3.1 Set HA .....	34
3.2 Set Station and instrument height .....	37
3.3 Measurement .....	38
3.4 Code .....	39



4. Functions	41
1. Level	41
2. Offset	42
2.1 Distance Offset	42
2.2 Cylinder Offset	43
2.3 Angel Offset	45
3. NP/P Toggle	47
4. Height Transfer	47
5. Hidden Point	50
6. Free Coding	53
7. Laser Pointer	53
8. Light	53
9. Unit Setting	53
10. Main Setting	54
11. EDM Tracking	55
5. Applications	56
1. Setting the Job	56
1.1 Create a new Job	56
1.2 Select an Existing Job from Memory	58
2. Setting the Station	59
2.1 Select the coordinate from memory [Find]	59
2.2 Select the Fix Point in the Memory [List]	61
2.3 Input the coordinates manually.	63
3. Setting the Orientation	64
3.1 Manual input orientation	64
3.2 Set orientation with coordinates	66
4. Starting the Applications	67
5. Surveying	68
5.1 Individual Point	70
5.2 Data	71
6. Stakeout	73
6.1 Set Stakeout Point	73
6.2 Polar Stakeout Mode	77
6.3 Orthogonal to Station Stakeout Mode	80
6.4 Cartesian Stakeout Mode	83

6.5 Polar .....	86
7. Resection .....	89
8. Tie Distance .....	92
8.1 Polygonal .....	92
8.2 Radial .....	95
9. Area & Volume .....	98
10. Remote Height .....	100
10.1 Prism High Unknown .....	103
11. COGO .....	104
11.1 Traverse .....	104
11.2 Inverse .....	108
11.3 Bearing-Bearing Intersection .....	110
11.4 Bearing-Distance Intersection .....	113
11.5 Distance-Distance Intersection .....	115
11.6 Line-Line Intersection .....	119
11.7 Distance-Offset .....	121
11.8 Set Point .....	122
11.9 Extension .....	125
12. Road .....	127
12.1 Road Manage .....	127
12.2 Road Stakeout .....	129
12.3 Result.Setting out .....	130
12.4 Transfer .....	130
13. Stakeout Reference Element .....	131
13.1 RefLine .....	131
13.2 RefArc .....	139
13.3 RefSurface .....	149
6. File manage .....	151
1. Job .....	151
1.1 Select a Job .....	151
1.2 New a Job .....	152
1.3 Delete a job .....	154
2. Fix Pt. ....	155
2.1 Search Fix Pt. ....	156
2.2 Add Fix Pt. ....	156
2.3 Edit Fix Pt. ....	158
2.4 Delete Fix Pt. ....	159



3. Meas. Pt. ....	159
3.1 View the measurement data .....	160
3.2 Delete measurement data .....	161
4. Code. ....	162
4.1 Input Code .....	162
4.2 View Code .....	163
4.3 Delete Code .....	165
5. Memory Statistics .....	166
7. Data Transfer .....	167
1. Data Import .....	167
2. Data Export .....	169
8. Instrument Setting .....	172
1. General Setting .....	172
2. EDM Setting.....	176
9. Adjust and Tools .....	177
1. Adjust .....	177
1.1 View adjust parameters .....	178
1.2 Adjust Index Error .....	179
1.3 Adjust Tilt X .....	179
1.4 Adjust Tilt Y .....	181
1.5 Adjust Tilt Zero .....	183
1.6 Instrument constant setting .....	184
1.7 Factory setting .....	184
2. System information .....	185
2.1 View System Information .....	185
2.2 Set System Date .....	185
2.3 Set System Time .....	185
2.4 Firmware Upgrade .....	186
3. Checkout and calibration .....	189
3.1 Tube level .....	189
3.2 Circular level .....	189
3.3 Telescope reticle .....	190
3.4 The verticality of collimation axis and horizontal axis(2C) .....	191
3.5 Vertical plate index zero automatic compensation .....	192
Vertical collimation error (I Angle) and vertical collimation zero value setting .....	192



3.7	Plummet .....	193
3.8	Instrument additive constant (K) .....	195
3.9	The parallelism of collimation axis and photoelectricity axis .....	195
3.10	No prism ranging .....	196
10.	Technical parameters .....	197
11.	Attachment B File format introduction .....	199

## **1. Name and function of each part**

### **1. Name**

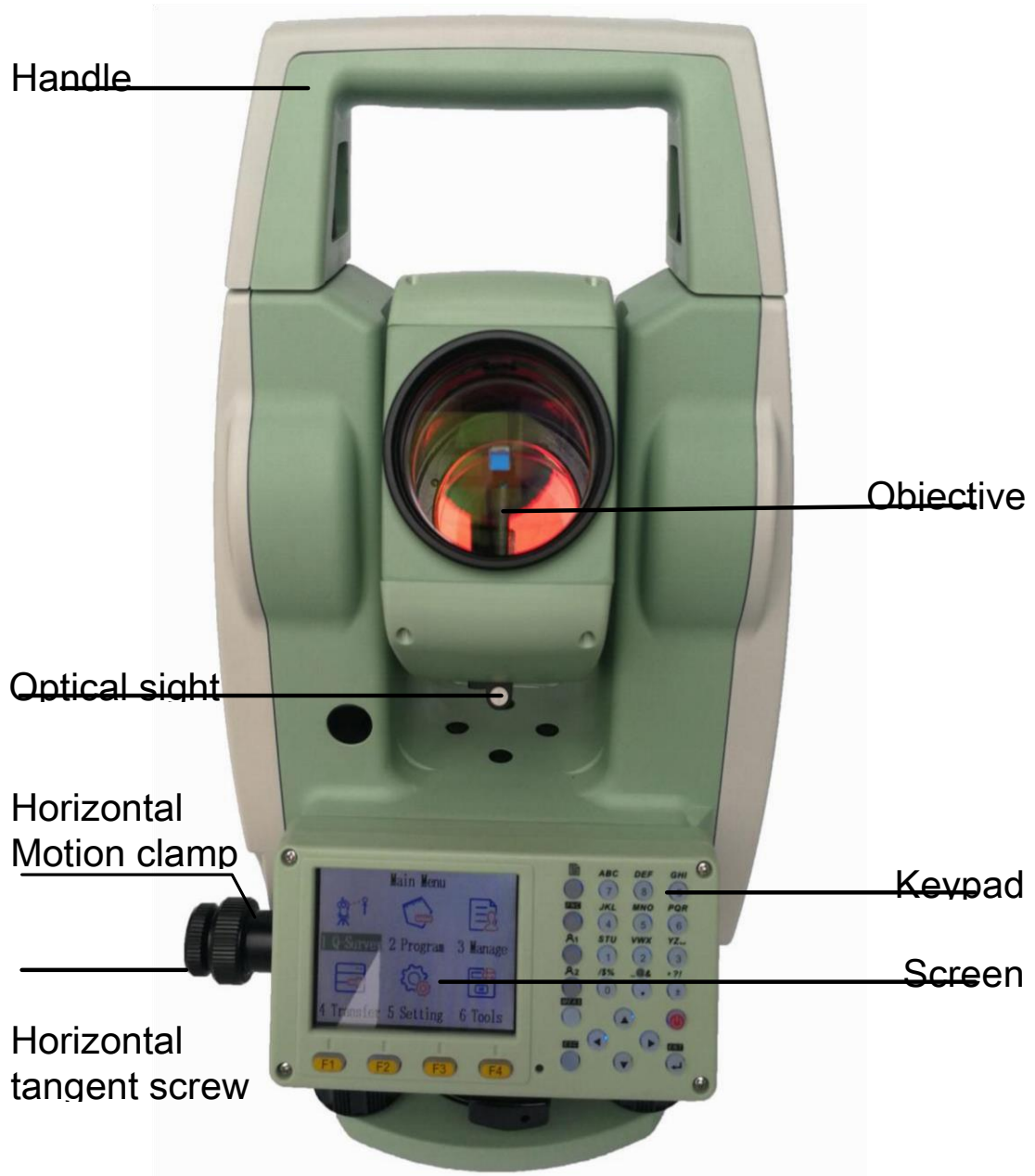



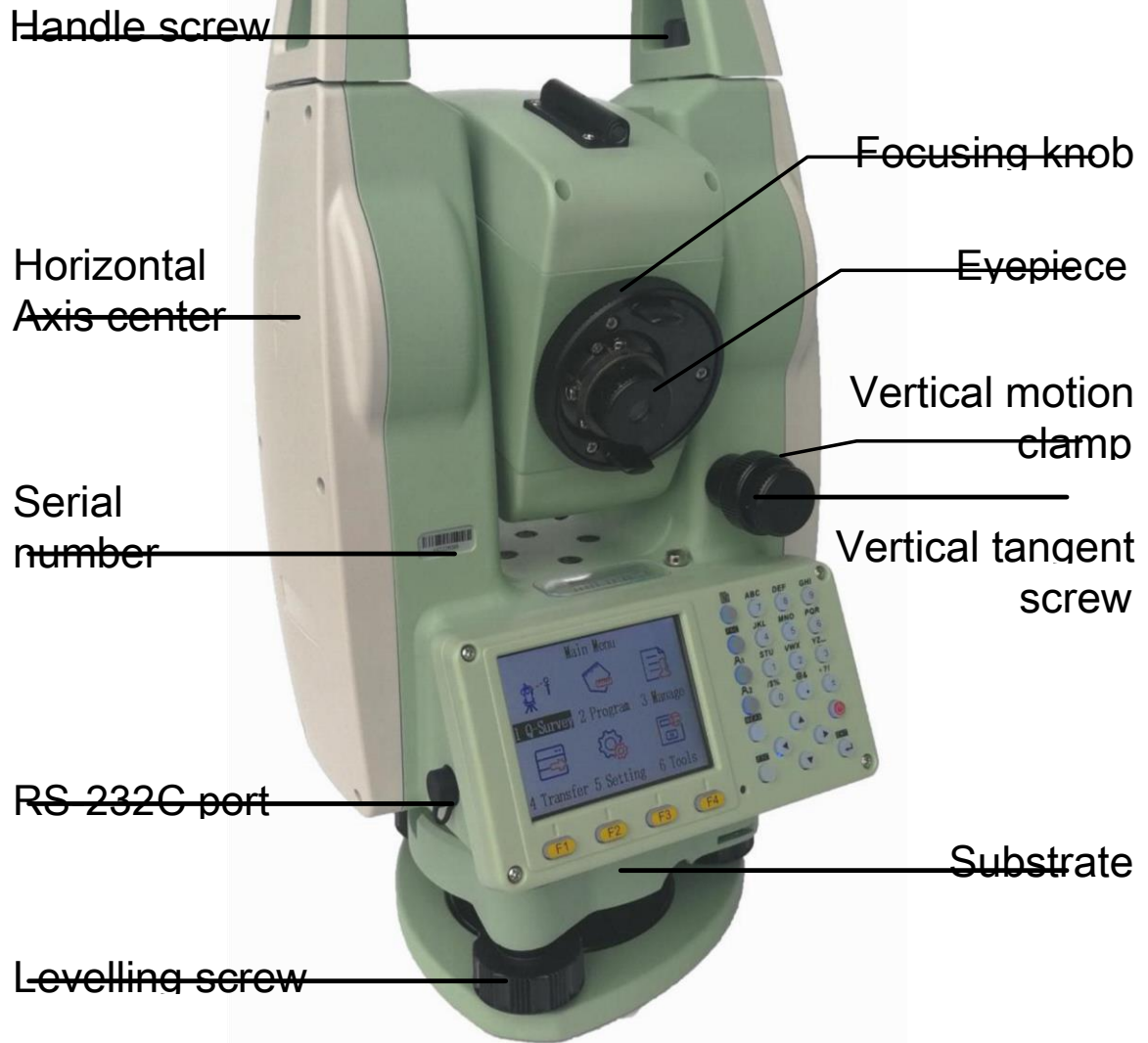









## 2. Keys Functions and information display



Key	Function
	Power ON/ Power OFF.
MEAS	Trigger key, depends on setting, maybe disting& save, disting or none.
ESC	Cancel or exit.
ENT	Confirm or commit editing.
	Page turning
<b>FNC</b>	Hot key to enter function menu in measuring interface.
	User defined function key 1.
	User defined function key 2
	Move cursor up or goto previous.
	Move cursor down or goto next.
	Move cursor left or goto left.
	Move cursor right or goto right.
STU GHI 1 ~ 9	Entering letters A-Z.
0 ~ 9	Entering number or choose menu item.
F1 ~ F4	Soft keys to choose screen bottom function.

## 2. Preparation before measurement

### 1. Unpack and store instrument

- Unpack

Put down the box gently and turn up the cover then turn on the lock, open the cover and take out the instrument.

- Deposit

Cover up the telescope mirror and make the vertical motion of alidade upwards then put the instrument horizontally (keep the objective upwards) into box. Then screw vertical motion gently. Cover up the box cover and lock the box. Loose horizontal and vertical axis as much as possible to reduce the shock damage to instrument.

### 2. Setting up the instrument

Install the instrument onto the tripod gently, then level and center the instrument to ensure the accuracy of the measurement result. ● Reference for operation:

#### 1. Centering and levelling 1)

Set up the tripod

① Position tripod legs so that the plummet is aimed to the ground mark point. Turn the focusing ring of the optical plummet to focus; ② Make sure that the center of the tripod top is right above the station; ③ Stamp the tripod on the ground with your feet.

#### 2) Install the instrument onto the tripod

Mount the instrument on the tripod head. Support it with one hand, and tighten the centering screw on the bottom of the unit to make sure it is secured to the tripod.

#### 3) Using the circular level to level the instrument coarsely

① Twist and adjust the two leveling screw A and B on the bottom of the instrument until the bubbles of the circular level moves to the line perpendicular to the center line the screw A and B;

② Twist and adjust leveling screw C to move the bubble to the center of the circular level.

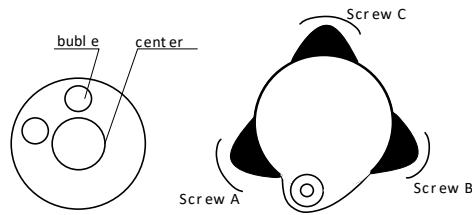

4) Using the plate level to level the instrument precisely

- ① Loosen the horizontal locking screw and turn the instrument around until the plate level is perpendicular to a line shaped with screws A and B. Adjust the screws A and B to make the bubble in the center of the level;

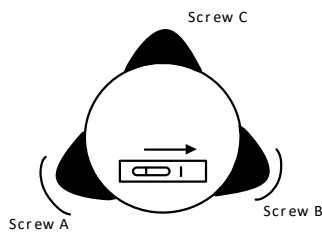

- ② Turn the instrument approximately 90° and adjust screw C until the bubble in the center of the level;

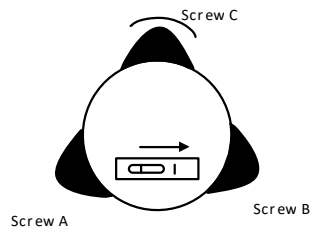

- ③ Turn around the instrument 90° again. Repeat above steps until the bubble remains in the center of the plate level even though the instrument is rotated to any position.

## 2. Centering by centering tool ( optional or laser )

1) Set up a tripod

Extend a tripod to the appropriate height make sure the legs are spaced at equal intervals and the head is approximately level .Set the tripod so that the head is positioned over the surveying point. Brace tripod on the ground and keep one leg fixed.

2) Set up instrument and spotting

Put instruments on a tripod carefully, and tighten the center connection screw. Adjust the optical centering tool to make reticule clear (open instrument and laser centering if it's a laser centering tool).Handle another two unfixed legs, and adjust

their position through the observation of the optical plummet. Make the three legs of the tripod fixed on the ground when the optical plummet is aligned to the station approximately. Adjust three feet screws of total station and keep the optical centering tool (or laser centering) aiming at the station accurately.

3) Leveling instrument roughly by circular level

(Same as The section above that discusses centering and leveling with plumb bob)

4) Leveling instrument accurately by tubular level

(Same as The section above that discusses centering and leveling with plumb bob)

5) Centering and leveling accurately

Loosen center connection screw slightly and move instrument horizontally (Don't rotate instrument) through observation to optical plummet, making the instrument aim at station accurately. Tighten the center connection screw and leveling instrument accurately again.

This operation should be repeated till the plumb aims at station accurately.

### 3. About the battery

#### ● Mounting the battery

☆ Fully charge the battery before measurement.

☆ Cut off the power before removing the battery.

▶ Step mounting the battery

1. Insert the battery to the instrument.
2. Press the top of the battery until you hear a click sound.

▶ Step Remove battery

1. Press the button downward.
2. Remove the battery by pulling it toward you.

#### ● Battery information

 — Power is adequate, operating available.

 — The battery can be used for 4 hours when this symbol first appears. If you cannot master the consumed time, you should prepare a spare battery or charge the battery before using.

 — End of the operation as soon as possible and replace the battery and charge if running out of power.

 — It takes several minutes for the instrument to shut down when this symbol first appears. The battery has few power now and should be replaced and recharged.

#### Notice:

- ① The operating time of battery depends on environmental conditions such as ambient temperature, time and times of charging and so on the battery is suggested to be prepared or charged ahead before operation to keep it safety.
- ② The battery symbol only indicates power capability under current measurement mode. The remained capacity of the battery shown under current mode does not guarantee its capacity under other modes .Because consumption of power in distance measurement mode is more than that in angle measurement mode ,the instrument may end ranging sometimes due to insufficient capacity of battery (when switching between modes).

**Notice in charging:**

- Though overcharging protection is installed in the instrument, please plug off the battery immediately after finishing charging.
- Charging range from  $0^{\circ}\sim\pm 45^{\circ}$  . Abnormal responds of instrument occurs over this range.
- Rechargeable for 300—500 times, it may shorten Service time of the battery completely.
- Charge the battery once a month no matter if it is used to prolong its longevity.

#### **4. Reflecting prism**

When measuring distance with prism mode, a reflecting prism must be set at the target site. You can connect the prism to the base, and then connect the base onto the tripod .you can also set the prism onto the centering rod. There are single-prism group and three prism group available on the market, so you can select them according to your requirements.

#### **5. Loading or unloading the base**

- Loading

Put the three fixed feet in the corresponding bases, make the instrument in a triangular base, clockwise lock the button by  $180^{\circ}$  to lock the base, and then fix screw with a screwdriver to screw it out at a fixed lock knob.

- Unloading

If necessary, the triangle base can be removed from the instrument (including the same base of reflection prism base connector) by loosening the lock knob base fixed screw with a screwdriver, and anticlockwise locking button about  $180^{\circ}$ , then separate the instrument from base.

## 6. Adjust telescope objective and aiming target

Aiming method (reference)

① Rotate the telescope and point it to the bright sky and focus reticule clearly (by rotating eyepiece in own direction and focusing reticule slowly ).

② Aim at the target with the crosswire in optical sight , and keep an appropriate distance when aiming ( about 200mm).

③ Use telescope focus screw to make target clear.

It means that focus or eyepiece diopter is not adjusted when there is a parallax with eye moving up and down, thus focus carefully and adjust eyepiece to reduce parallax.

## 7. Input Mode

Total station keyboard includes alpha/digit keys. User can input letters and numbers directly.

### ● Input box:

Each digit key defines 3 letters and 1 number. Depends on the properties of input box, input process varies.

Number input box:

In number input box, user can only input numbers, include "1-9", ".", "-+".

Number will appear in box when user presses the key.

Text input box:

In text input box, user can input numbers and letters. Repeat pressing same key to get proper letter, such as A->B->C->7.

└A

When right-bottom of screen display icon , user can input number/letter; when display





icon , user can only input number. User can press soft-key [F4] to switch input mode

between Number and Text when input box been active.

└1

### ● Letters:

Letters that total station can input includes "A-Z/\$%\_@&\*?!+-.". When wildcard queries, you need to use the "\*" character and press the ± key twice in the character input mode of the total station,.

- Arrow key,   move inputting cursor.
- Pressing  enters editing; pressing  confirms input after editing.
- When editing distance, angle, temperature and pressure values that contain unit format, input box's text will convert into text without unit format. Such as angle

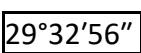
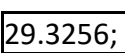
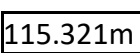
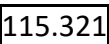
 transforms into ; Distance  transforms into . When finish editing, the text will automatic convert back.

## 7.1 Input characters

Each digit key defines 3 letters and 1 number. In text input mode, each time pressing the key, one character appears at cursor position. Number appears when pressing 4 times.

Example: input 123ABV2

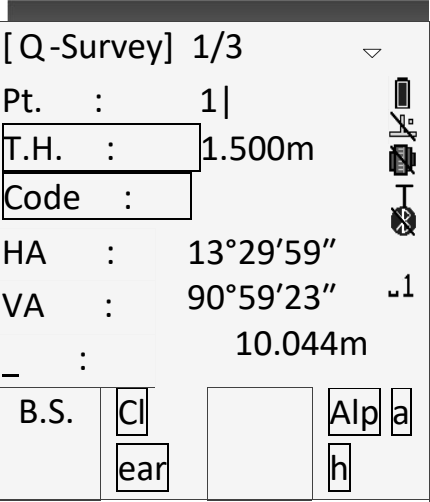
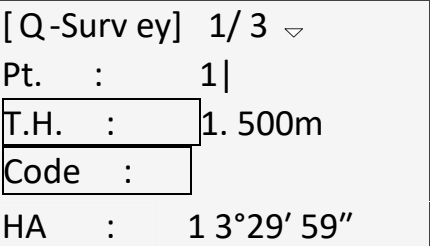
Steps	Key	Display
<p>O1 Pressing key to start inputting. Right-bottom screen displaying icon means in number input mode.</p> <p style="text-align: center;">┌1</p>		
<p>O2 Press key 1, key 2, key 3. Then press key F4, active text</p>	[1],[2],[3],[F4]	



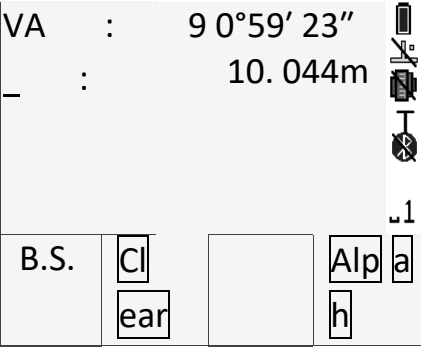
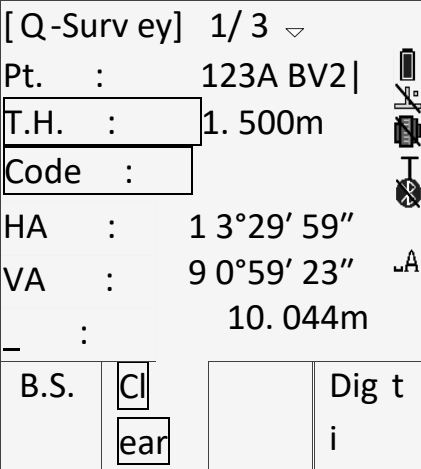
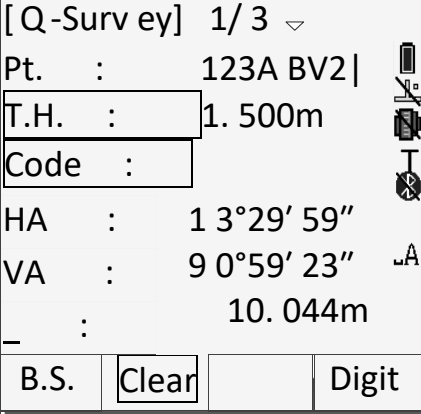

<p>input mode. Icon should appear in right bottom screen.</p> <p style="text-align: center;">└A</p>		
<p>○3 Press key 7, display letter 'A', wait about half second, press key 7 twice, display letter 'B', then press key 2, display letter 'V', wait about half a second, press key 2 four times, display number '2'. Then finished text '123ABV2' input.</p>	<p>[A],[B],[V],[2]</p>	
<p>○4 Press key ENT to finish editing, cursor will move down to next input box.</p>	<p>[ENT]</p>	

## 7.2 Delete characters

Delete or clear input characters.

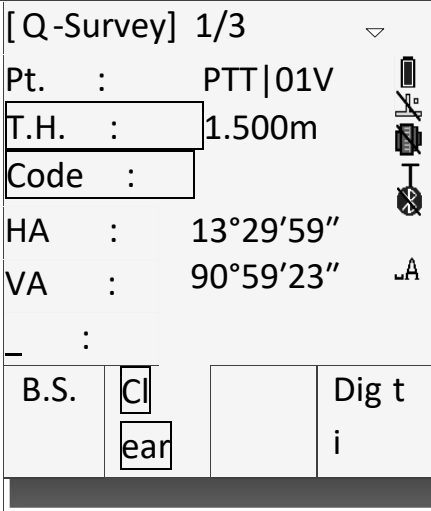
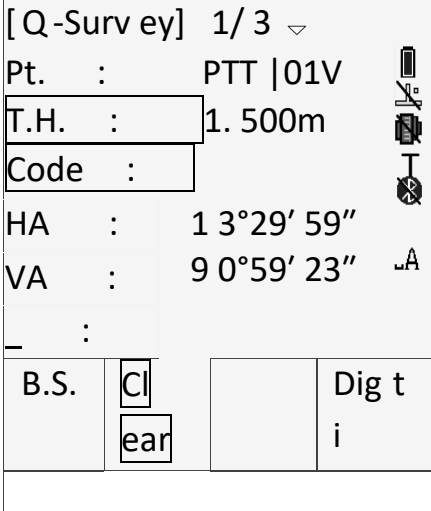
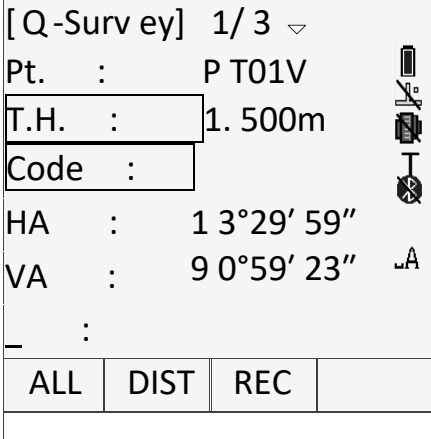

Steps	Key	Display
 <p>O1 Press key  to move cursor to right side of the character that to be deleted.</p>		
<p>O2 Press key F1(Delete).</p>	<p>[F1]</p>	
<p>O3 Press key ENT to confirm input. Press Key ESC to undo changes.</p>	<p>[ENT] / [ESC]</p>	

## 8. Point Search

Point search is a function used by applications to find measured or fixed points in the jobs.◦



Point search is limited to a particular job.

If several points meet the search criteria, then the results are ordered according to the date.

## 8.1 Direct search

By entering an actual point number (for example 'A1'), and pressing key SEARCH, all points within the selected job and with the corresponding point number are found.

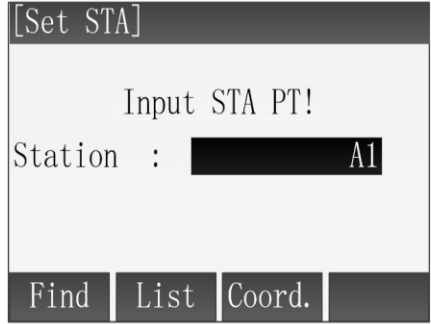
Here is an example for searching fix point in function 'Set STA'.

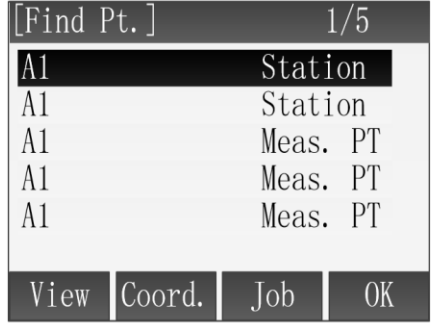
Steps	Key	Display
<p>① Choosing 'Survey' in application menu, then choose function 'Set STA'. Entering point number, for example 'A1', pressing ENT to finish input, then pressing F1 to search.</p>	[F1]	
<p>② In searching result window, using arrow key  to move cursor to select point number. Press key F4 or ENT to confirm selecting.</p>	 +[F4]/ [ENT]	



Soft keys introduction:

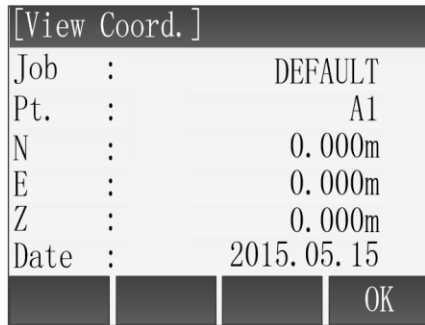
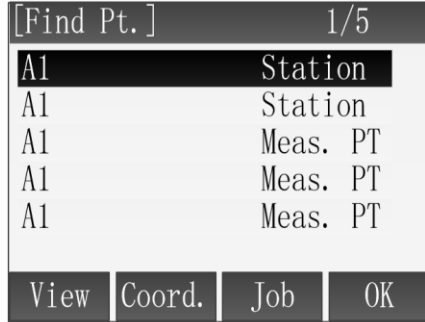

[View] Show the coordinate of selected point.

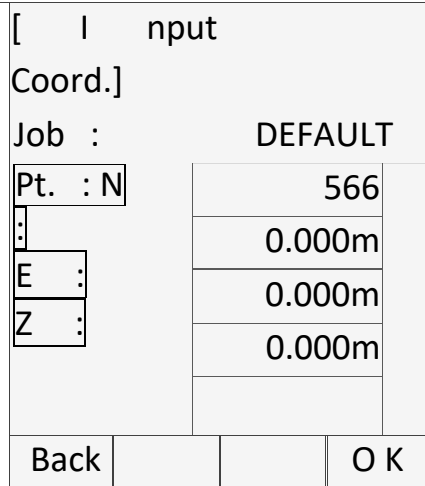
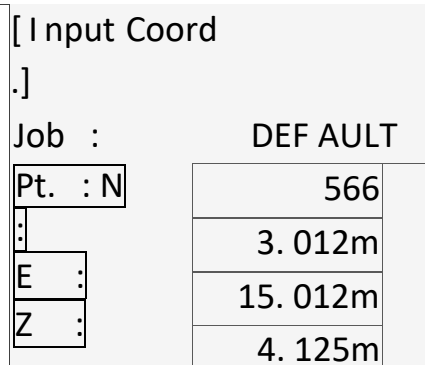
<p>③ Using arrow key <input type="text" value="↑"/> <input type="text" value="↓"/> to move cursor and select point number. Press key F1 to show the coordinate details of selected point.</p>	<p>[F1]</p>	
<p>④ Press ESC or F4 back to previous screen.</p>	<p>[ESC] [F4]</p>	

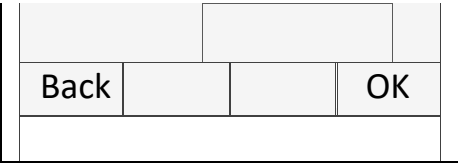
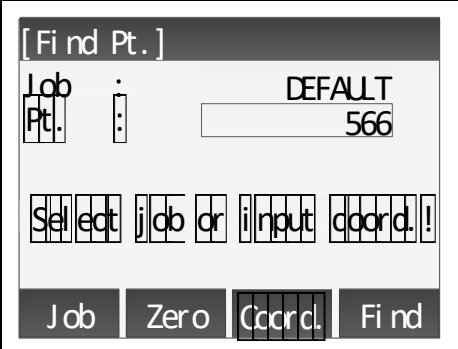
[Coord.] Input point manually.

<p>③ If required point not exists in the job, user can manually input it by pressing key F2. by pressing ENT to input box.</p>	<p>[F2]</p>	
<p>④ Input point number and N, E, Z values, by pressing ENT to move cursor to next input box.</p>	<p>[ENT]</p>	

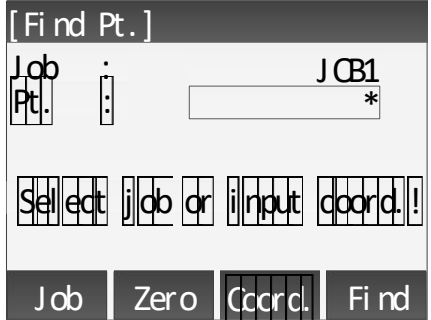
		
<p>○5 After all values finishing input, pressing key F4 to save the point to the job.</p>	[F4]	
[Job]Choose another job's points.		
<p>○3 If required point not exists in the job, user can choose another job's points.</p>	[F3]	
<p>○4 Entering job list by pressing key F1, choose the particular job and press ENT or F4 to commit choosing.</p>	[F1] [F4] [ENT]	

<p>☞ Entering searching point number. If using input point, press key F2 (Zero) or F3 (Coord.)<sup>1</sup></p>	<p>[ENT]</p>	
<p>☞ Press key F4 to search the point in the selected job.</p>	<p>[F4]</p>	
<p><sup>1</sup>[F2](Zero): Set N, E, Z to 0.  [F3](Coord.): Input point manually.</p>		

[OK] Commit selected point.

## 8.2 Wildcard search

The wildcard search is indicated by a “\*”. The asterisk is a place holder for any following sequence of characters. Wildcards should be used if the point number is not fully known, or to search for a batch of points.

Examples:

- \* All points are found.
- A All points with exactly the point number “A” are found.
- A\* All points containing “A” are found, for example, A1, A2, 1A.

Steps: (For example “\*”)

Steps	Key	Display
-------	-----	---------

<p>○1 Choosing 'Survey' in application menu, then choose function 'Set STA'. Entering "*", pressing ENT to finish input, then pressing F1 to search.</p>	<p>[F1]</p>	<p>[ Set STA ]</p> <p style="text-align: center;">Input STA PT!</p> <p>Station : <input style="width: 100px;" type="text"/></p> <p style="text-align: right;">A1</p> <p>Find List <u>Coord.</u> <input style="width: 30px;" type="text"/></p>
<p>○2 In searching result window, using arrow key <input style="width: 20px; height: 20px; border: 1px solid black;" type="text" value="↑↓"/> to move cursor to select point number. Press key F4 or ENT to confirm selecting.</p>	<p><input style="width: 20px; height: 20px; border: 1px solid black;" type="text" value="↑↓"/></p> <p>[F4] [ENT]</p>	<p>[ Find Pt.] 1/5</p> <p><b>A1</b> Station</p> <p>A1 Station</p> <p>A1 Meas. PT</p> <p>A1 Meas. PT</p> <p>A1 Meas. PT</p> <p>View <u>Coord.</u> Job OK</p>

### 3. Q-Survey

#### 1. Notes in the distance measurement

After the placement of instrument and turned on the power, total station is ready, can start measuring.

In measurement display, user can call the function of set key, the function keys and hotkey.

The show is an example. Localized version may be slightly different.

The example of Q-Survey show:

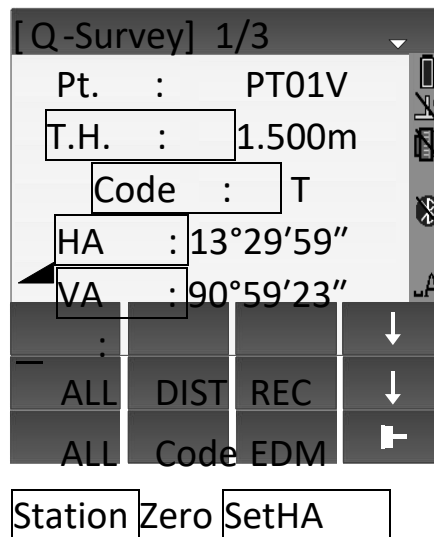

F1-F4 Start the corresponding functions

#### Notes:

**Measurements to strongly reflecting targets such as to traffic lights in Reflector EDM mode without prism should be avoided. The measured distances may be wrong or inaccurate.**

**When a distance measurement is triggered, the EDM measures to the object which is in the beam path at that moment.**

If e.g. people, cars, animals, swaying branches, etc. cross the laser beam while a measurement is being taken, a fraction of the laser beam is reflected and may lead to incorrect distance values.

Avoid interrupting the measuring beam while taking reflector less measurements or measurements using reflective foils.

➤ No Prism Ranging





- ◆ Ensure that laser beam is not reflected by any object with high reflectivity and close to the light path.
- ◆ When start the distance measurement, EDM will measure distance for the object in the light path. If there are temporary obstacles in the light path (such as by car, or the heavy rain, snow, or filled with fog), the distance measured by EDM is the distance to the nearest obstacle.
- ◆ When a long distance measurement, laser beam deviation of collimation line will affect the accuracy of measurement. This is because the divergence of the laser beam reflection point may not be with the crosshair sighting points coincide. It is recommended that the user accurately adjust to ensure that is consistent with laser beam collimation.(Please refer to “20.10 NO Prism Ranging”in the Chapter 9)
- ◆ Don't use two instruments to measure the same target at the same time .
- Red light cooperates with reflective pieces to measure distance  
Laser can also be used to measure distance for reflective pieces. To guarantee the accuracy of measurement, the laser beam is perpendicular to the reflector plate, and through accurate adjustment.(Please refer to “3.10 NO Prism Ranging”in the Chapter 9)



**Ensure proper additive constant of different reflection prism.**

## 2. EDM Setting

### 2.1 Set the mode of EDM

Select the mode of distance measurement, there are 6 modes :

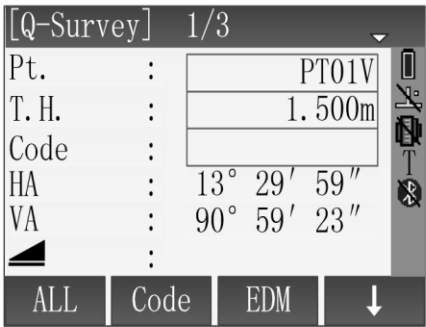
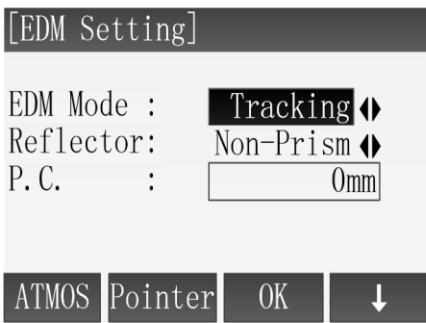
Single, Repeat, Tracking, 3 Times, 4 Times, 5 Times.









Steps	Key	Display
① Press [F4]( ↓ ) and show the second soft key in the Q-Surveying. Press [F3] to enter the interface of EDM Setting.	[F4] [F3]	
② When the cursor is in EDM mode option, Press the direction key of ←→ to select the mode of measurement. Each time you press ← or →, the mode of measurement is switched.	← →	
③ After finishing setting, press [F3](OK) to return the function of Q-Surveying. If you want to cancel the settings, press [ESC] to ignore the changes.	[F3]	

#### Set the reflector type

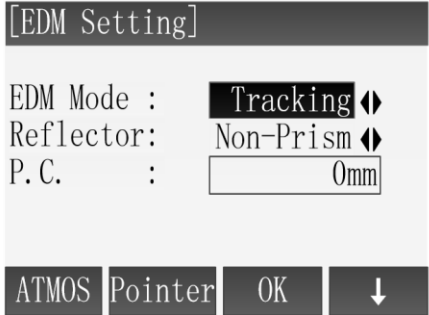
Our series total station can be set up for the red laser (RL) range and invisible infrared light (IR) range and the total station has three reflectors to be selected, which

are prism, non-prism (NP) and reflect board (Sheet). You can set by job, but the prism used should be matched with prism constants.

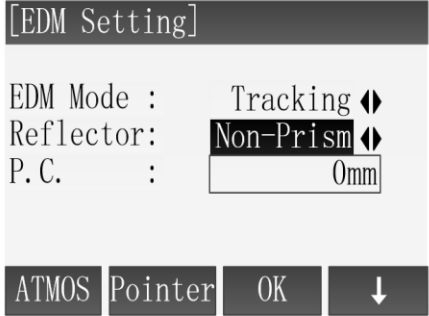
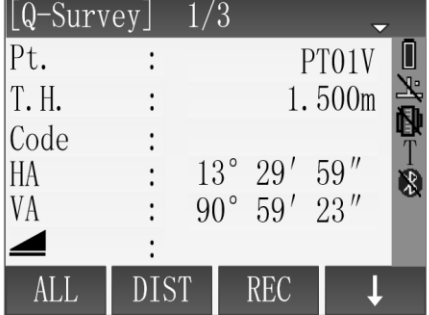

➤ **About the parameters of various reflectors in distance measurement, please refer to “Technical Parameters”.**

Steps	Key	Display
<p>① After entering to the interface of EDM Setting, using the direction of  to move the cursor to the setting item of Reflector.</p>		
<p>② Press  to select the types of reflector. Each time you press  or , the type of reflector is switched.</p>	 	
<p>③ After finished setting, press [F3] (OK) to return the function of Q-Surveying. If you want to cancel the settings, press [ESC] to ignore the changes.</p>	[F3]	

### Set up the Reflecting Prism Constant.

As a prism is selected as a reflector, a prism constant should be set before any measurement. If the constant is entered and set, it is saved and will not be erased after switching off the instrument.

Example: Prism Constant is -30mm

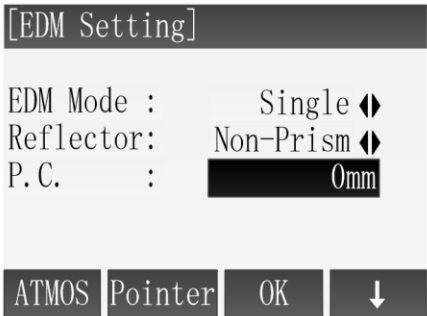
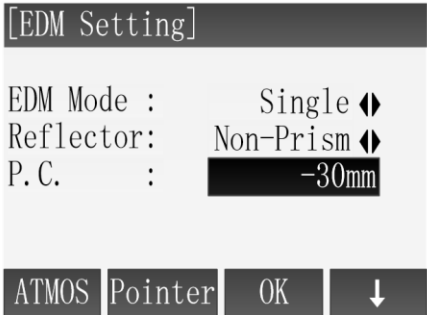
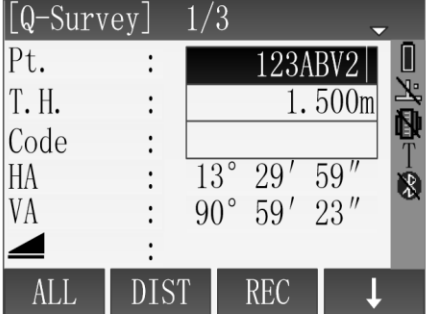
Steps	Key	Display
<p>① After entering to the interface of EDM Setting, using the direction of  to move the cursor to the setting item of P.C.</p>		
<p>② Enter the prism constant value and press the key of [ENT]. ※<sup>1</sup>※<sup>2</sup>※<sup>3</sup></p>	[ENT]	
<p>③ After finished setting, press [F3](OK) to return the function of Q-Surveying. If you want to cancel the settings, press [ESC] to ignore the changes.</p>	[F3]	
<p>※<sup>1</sup>: Prism constant you enter is effective only when the reflector mode is Prism.          ※<sup>2</sup>: The range of Prism constant value: -99mm ~ +99mm.</p>		

## 2.2 Atmosphere setting

### Refraction:

When measuring horizontal distance and elevation, our instrument corrects the atmospheric refraction and the earth curvature automatically.

The instrument supports of atmospheric refraction coefficient have three option, they are 0.00, 0.14, and 0.20.

**Note:** The refraction of instrument has been set for K=0.00 when left factory .It also can be set to other values

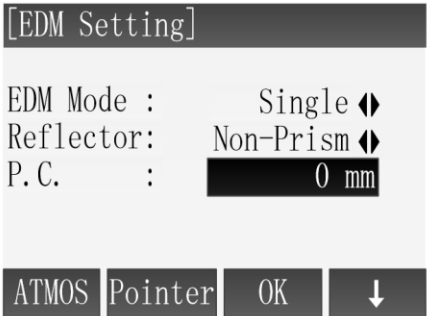
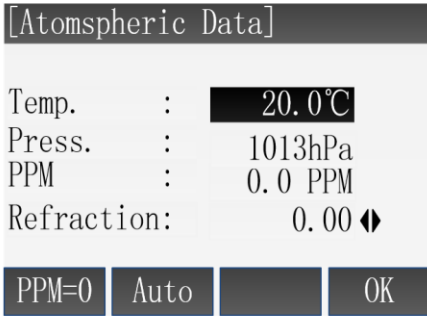
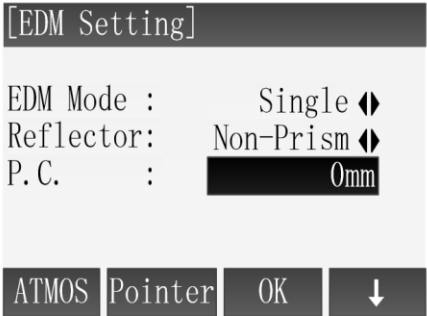
Steps	Key	Display
<p>① After entering to the interface of EDM Setting, press [F1] (Atoms) to enter the interface of Atmospheric Data.</p>	[F1]	 <p>[EDM Setting]</p> <p>EDM Mode : Single ◀▶</p> <p>Reflector: Non-Prism ◀▶</p> <p>P. C. : 0 mm</p> <p>ATMOS Pointer OK ↓</p>
<p>② Interface displays the current setting, using the direction of ↓ to move the cursor to the setting item of Refraction.</p> <p>Press ↔ to select the value of refraction. Each time you press ← or →, the value of refraction is switched.</p>	<p>↓</p> <p>+</p> <p>↔</p>	 <p>[Atomspheric Data]</p> <p>Temp. : 20.0°C</p> <p>Press. : 1013hPa</p> <p>PPM : 0.0 PPM</p> <p>Refraction: 0.00 ◀▶</p> <p>PPM=0 Auto OK</p>
<p>③ After finished setting, press [F4] (OK) to save settings and back to previous menu.</p> <p>If you want to cancel the settings, press [ESC] to ignore the changes</p>	[F4]	 <p>[EDM Setting]</p> <p>EDM Mode : Single ◀▶</p> <p>Reflector: Non-Prism ◀▶</p> <p>P. C. : 0mm</p> <p>ATMOS Pointer OK ↓</p>

### Atmospheric Correction:

When measuring distance, the measured value will be influenced by the atmosphere.

In order to reduce the influence, a atmospheric correction parameter is needed.



Correction value associated with the pressure and temperature in air. Calculated as follows:

$$\text{PPM} = 277.8 - (0.2900 * \text{the air pressure(hPa)}) / (1 + 0.00366 * \text{temperature(}^\circ\text{)})$$

If the air pressure unit is mmHg, Make a conversion according to the formula:

1hPa=0.75mm Hg

➤ Standard meteorological conditions (atmospheric correction value =0):

press: 1013hPa    temperature:

20`

➤ If the atmospheric correction is not required, please set PPM to zero.

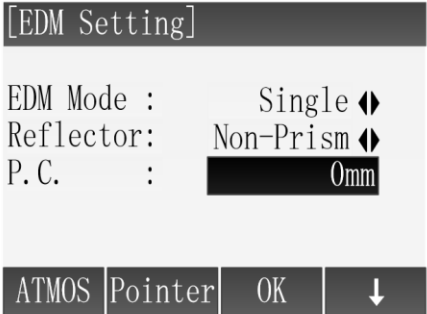
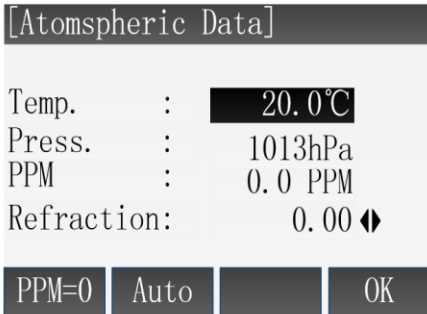
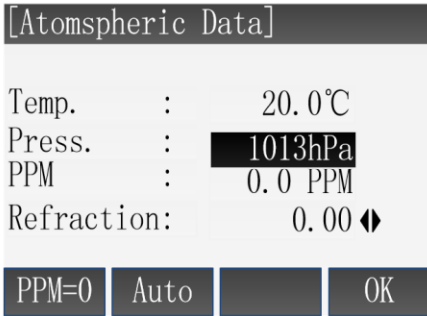
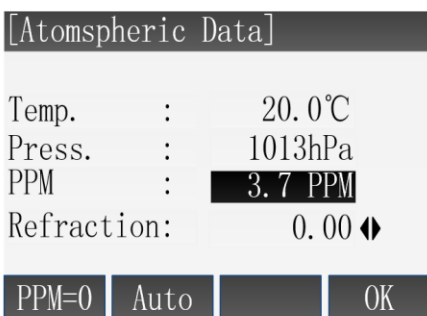
Steps	Key	Display
<p>① After entering to the interface of EDM Setting. Press [F1] (Atoms) to enter the interface of Atmospheric Data.</p>	[F1]	
<p>② Interface displays the current settings.</p>	↓	
<p>③ Input the value of temperature. example: Enter 26°C and press the key of [ENT]. The cursor moves to the setting item of Press.</p>	[ENT]	
<p>④ Input the value of atmospheric pressure. example: Enter 1020 hPa and press the key of [ENT]. Program calculates the value of PPM and the cursor moves to the setting item of PPM. ※<sup>1</sup>※<sup>2</sup>※<sup>3</sup>※<sup>4</sup></p>	[ENT]	

<p>O5 After finishing setting, press [F4](OK) to save settings and back to previous menu. Then press the key of [F3](OK) to save the setting of EDM and back to the function of measurement.</p>	<p>[F4] [F3]</p>	<p>[ A tomspheric Data]</p> <p>Temp. : 20.0`          Press. : 1013hPa          PPM : 0.0 PPM          Refraction: 0.00</p> <p><input type="text" value="PPM=0"/> Auto                      OK</p>
<p>""1: The range of enter: Temp.(-30` ~ 60`), Press.(500hPa~1400hPa).          ""2: The instrument calculates the value of PPM according to the values of temperature and pressure you enter.          ""3: Press [F1](PPM=0) can set the value of PPM to 0.          ""4: If instrument supports temperature pressure sensor, you can press [F2] to receive the values of air pressure, temperature and calculate the correction value automatically.</p>		

### 2.3 Grid factor setting

When calculating the coordinates, the horizontal distance measured must multiply by the scale factor.

#### Computation formula

1. Altitude factor =  $R / (R + ELEV)$

R: The average radius of earth

ELEV: mean sea level altitude

2. Scale factor

Scale factor: Scale factor of the station

3. Grid factor

Grid factor = altitude factor × scale factor

#### Distance calculation

1. Grid distance

HDg = HD × grid factor

HDg: Grid distance

HD: Ground distance



2. Ground distance  $HD=HDg/(\text{Grid factor})$

**Note:**

1. The enter range of the scale factor: 0.99~1.01, the default value is 1.0.

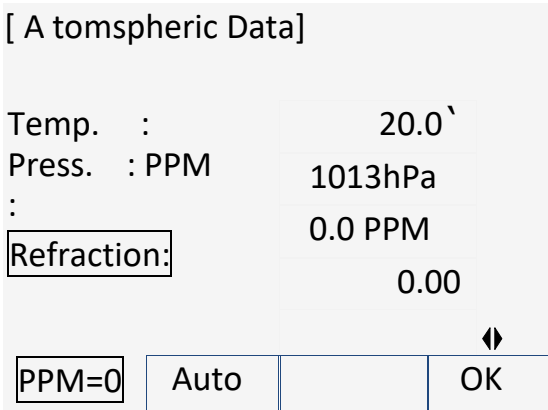
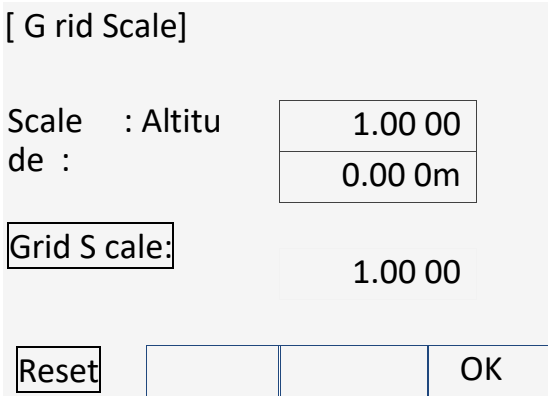
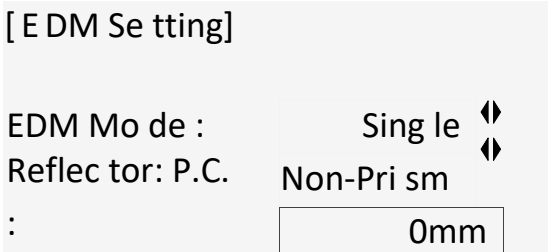
Steps	Key	Display
<p>○1 After entering to the interface of EDM Setting, press the key of [F4] to enter the second page of soft key, then press the key of [F1](Grid) to set the Grid Scale.</p>	<p>[F4] [F1]</p>	
<p>○2 Interface displays the current setting. Enter the values of Scale and Altitude then press the key of [ENT].Program calculates the Grid Scale and displays it in the interface. If you want to set all enter area to 0,you can set the key of [F1] (Reset).</p>	<p>[ENT]</p>	
<p>○3 After finished setting, press [F4](OK) to save settings and back to previous menu. Then press the key of [F3](OK) to save the</p>	<p>[F4]</p>	

setting of EDM and back to the function of measurement.

ATMOS

Pointer

OK

2. The enter range of the average height above sea level: -9999.9999~9999.9999. The average altitude retained after the decimal point one, the default value is 0.

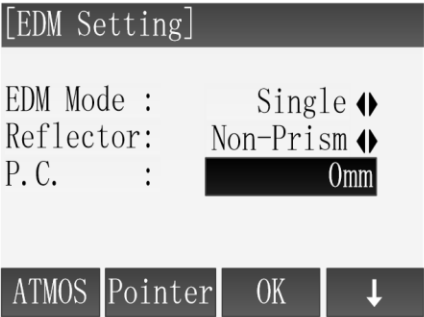
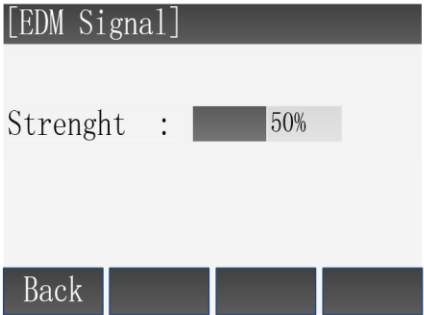
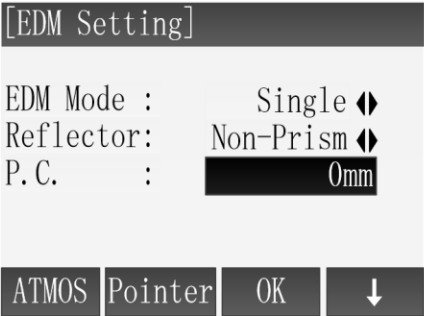

Steps	Key	Display
<p>① After entering to the interface of EDM Setting, press the key of [F4] to enter the second page of soft key, then press the key of [F2](Signal) to enter the function of Signal intensity.</p>	<p>[F4] + [F2]</p>	 <p>[EDM Setting]</p> <p>EDM Mode : Single ◀▶          Reflector: Non-Prism ◀▶          P. C. : 0mm</p> <p>ATMOS Pointer OK ↓</p>
<p>② Using the bar chart and value of number to show the intensity of signal received by total station in the screen. As shown in the picture on the right.</p>		 <p>[EDM Signal]</p> <p>Strenght : 50%</p> <p>Back</p>
<p>③ Press [F1] or [ESC] to back to the menu of EDM setting.</p>	<p>[F1] or [ESC]</p>	 <p>[EDM Setting]</p> <p>EDM Mode : Single ◀▶          Reflector: Non-Prism ◀▶          P. C. : 0mm</p> <p>ATMOS Pointer OK ↓</p>

## 2.4 EDM signal

The function of signal is to display the intensity of signal received by total station. If the target is hard to be found or can't see, using the function can achieve the best sighting accuracy.

## 3. Start measurement

Q-Survey has 3 pages menu, including all measuring functions commonly used, such as angle measurement, distance measurement and coordinate measurement.

As shown below:

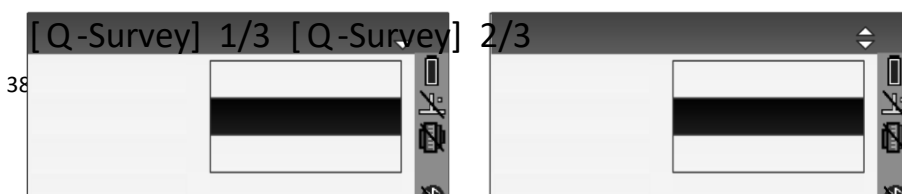

Pt. : 123ABV2    Pt. : 123ABV2  
 T.H. : 1.500m    T.H. : 1.500m  
 Code : T    Code : T  
 HA : 13°29'59"    HA : 13°29'59"  
 VA : 90°59'23"    : -0.173m  
 \_ : 10.044m    \_ : 10.044m  
 ALL DIST REC    ALL Code EDM

[ Q -Survey] 3/3

Pt. : A1  
 T.H. : 1.500 m  
 Code : T  
 N : 9.829 m  
 E : 2.360 m  
 Z : -0.275 m Station  
 Zero SetHA

### 3.1 Set HA



You can set the horizontal angle as 0 or set it as wanted angle.

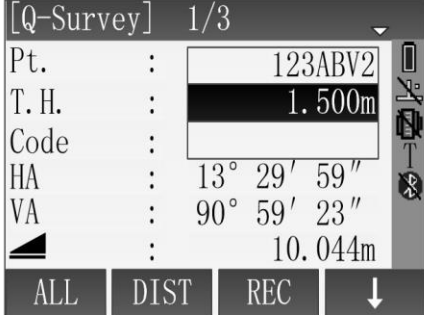

#### Set horizontal angle to 0.

Steps	Key	Display
<p>O1 Aim at the target which used to orient. Press [F4] twice to enter third pages soft key.</p>	<p>[F4] + [F4]</p>	<p>[ Q -Survey] 1/3            Pt. : PT01V            T.H. : 1.500m            Code : T            HA : 13°29'59"            VA : 90°59'23"            _ :            ALL DIST REC            ALL Code EDM            Station Zero SetHA</p>

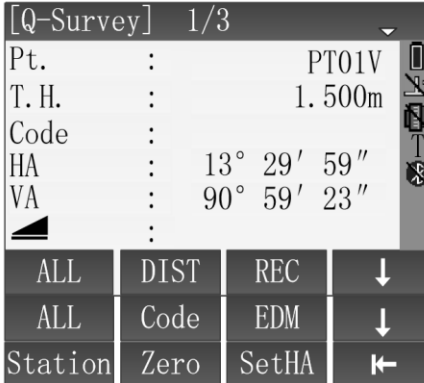
<p>② Press [F2](Zero), the screen give a prompt to set HA as 0 or not.</p>	<p>[F2]</p>	
<p>③ Press [F4](Yes), the screen backs to Q-Survey and HA is set as 0. If you want to cancel the operation, please press [F1](No).</p>	<p>[F4] or [F1]</p>	

### Set HA.

Steps	Key	Display
<p>① Aim at the target which used to orient. Press [F4] twice to enter third pages soft key.</p>	<p>[F4] + [F4]</p>	
<p>② Press [F3](SetHA) to enter the interface of SetHA. Screen displays the current value of HA.</p> <p>A: If want the current value of HA as the orientation angle, press [F4](OK) or press [ESC] to go back.</p>	<p>[F3]</p> <p>[F4]</p>	 <p>A: [OK]</p>

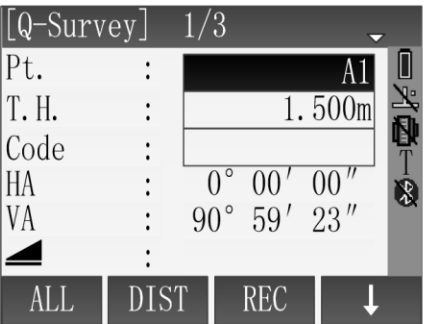
<p>B</p> <p>If want other value of angle as the orientation angle, you need to enter the wanted value of angle and press [ENT], then press [F4](OK).</p> <p>Example: enter 121.2030 (121° 20' 30").</p> <p>C:</p> <p>If want to set HA to 0,press [F1]( Zero) and the value in the edit text of HA becomes 0° 00' 00".Then press the key of [F4] (OK).</p>	<p>[F4]</p> <p>[F1] +</p> <p>[F4]</p>	 <p>B: Input angle</p>  <p>C: [Zero]</p> 
<p>③ Back to the function of Q-Survey, the value of HA just set displays in the interface. Here take an example of setting HA to zero.</p>	<p>[F4] [F1]</p>	

### 3.2 Set Station and instrument height

After set the coordinate of station (the site of instrument) relatives to the origin, the instrument can calculate the coordinate of the location to your position (the site of prism).

You can set station and the instrument height conveniently in the Q-Survey.

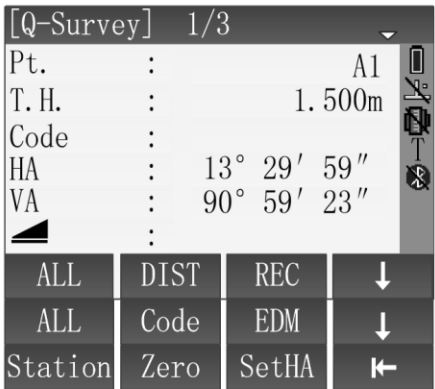
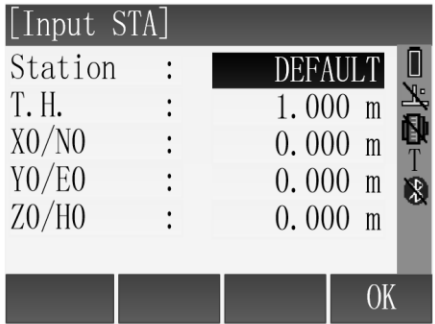
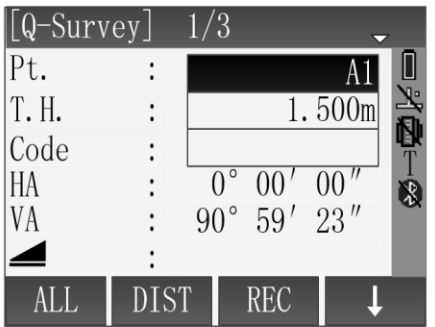
Steps	Key	Display
<p>① Aim at the target which used to orient. Press [F4] twice to enter third pages soft key.</p>	<p>[F4] + [F4] + [F2]</p>	
<p>② Press [F1] (Station) to enter the interface of Enter STA. Enter the name of station, the instrument height and coordinates. After entering each item, move the cursor to the next edit text.</p>	<p>[F1]</p>	
<p>③ After finished entering, press [F4] (OK) to save the data of station and back to the function of Q-Survey.</p>	<p>[F4]</p>	

### 3.3 Measurement

After all settings have been finished, you can start to measure. There are 3 pages to display the result of measurement, including all measurement data and you can press [PAGE] to view.

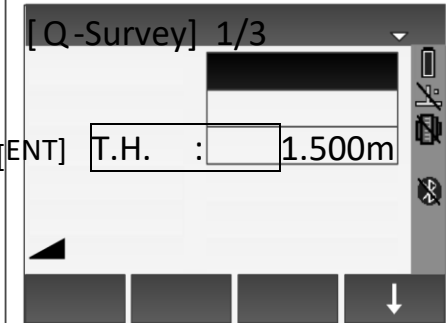
Steps	Key	Display
<p>O1 Input the name of point and Pt.</p>	<p>:</p>	<p>A1</p> 



instrument height. Move the  <sup>T</sup>  
 + cursor to the next edit text after HA  
 : 0°00'00"  
 [ENT] VA : 90°59'23"  
 entering each item. You can enter  
 Code when necessary. ALL DIST REC :

O2 Aim at the center of prism,

press [F1](ALL) or [F1] Pt. : [ Q-Survey] 1/3  
 or  1.500m

measure and record the [F2] HA : 0°00'00" <sup>T</sup>  
 measurement data. The + VA : 90°59'23" measurement data  
 including angle [F3] \_ : 10.044m data, distance data and coordinate  
 ALL DIST REC data. You can press [PAGE] to view.

O3 After finishing measuring a point,  
 program makes the number of point  
 add 1 automatically, aim at the  
 center of prism and repeat the  
 above steps to start next point  
 measurement.

Pt. : A1  
 1.500m  
 <sup>T</sup>  
 HA : 0°00'00"  
 VA : 90°59'23"  
 \_ :10.044m  
 ALL DIST REC

[ Q-Survey] 1/3

### 3.4 Code

The code contains the information about the recording points, in the process of post-processing, with the help of encoding function , you can process conveniently according to the specific group. The function of "File Manager" also contains the information of code.

#### Simple Operation of Code

1. Move the cursor to the line of Code.

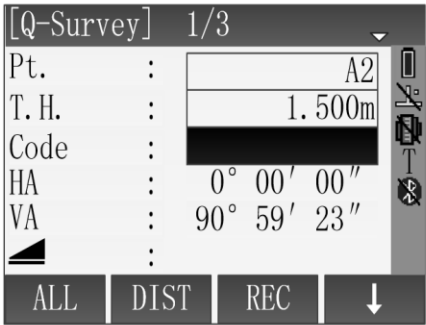
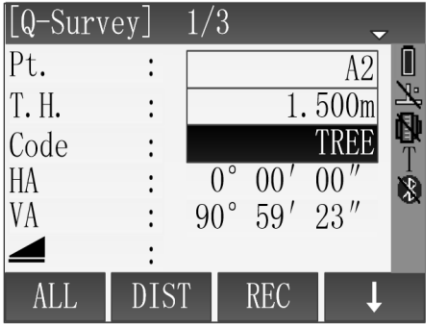
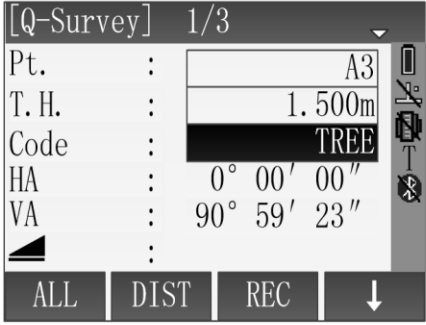

2. Enter the name of Code.
3. Press the key of [ALL] to start the distance measurement and record the data of code and measurement at the same time. If the name of code already exists in the code library, it will extract the information of code in the code library to record at the same time.

Steps	Key	Display
① Move the cursor to the line of Code.	↓	
② Enter code and press [ENT] to make sure. The entered code here will not be added to the code library.	Input code + [ENT]	
③ Press [F1] to start to measure, record the code and the date of measurement to job at the same time. ※ <sup>1</sup>		

※<sup>1</sup>: The order to save code and measurement data is set in the "Setting" function.

The set items of code record are Before REC and After REC.

Before REC: Record code data before recording the actual measurement data. After REC: Record code data following after the actual measurement data.

### Soft key of Code

After starting the function of soft key (Code), Screen displays the following:

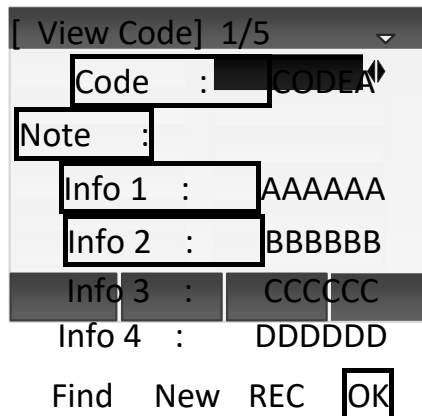

GSI-the introduction of code properties:

Code: The name of code

Note: The additional note

Info1: The editable information of other contents

Info8: Other information

The introduction of soft key:

**[Find]:** Use the name of code or wildcard to find the needed code.

**[New]:** New a piece of editable information of code and use it.

**[REC]:** Record the current code data to the job and the code data not with any measurement point binding at this time.

**[OK]:** Select the current code and use it.

Using the soft key of [Code] can select the code in the code library directly, it will back to the interface of Q-survey after selecting, the code in the edit text of Code is the selected code.

## 4. Functions

Bring the total station's common functions and settings together, they can be used in the process of measurement conveniently. In the function of Q-Survey which in the Main menu or other interface of measurement in the program, you can press [FNC] to enter the menu of Function

The menu of Function has 4 pages, you can press **[PAGE]** to view.  
The specific introduction as follows:

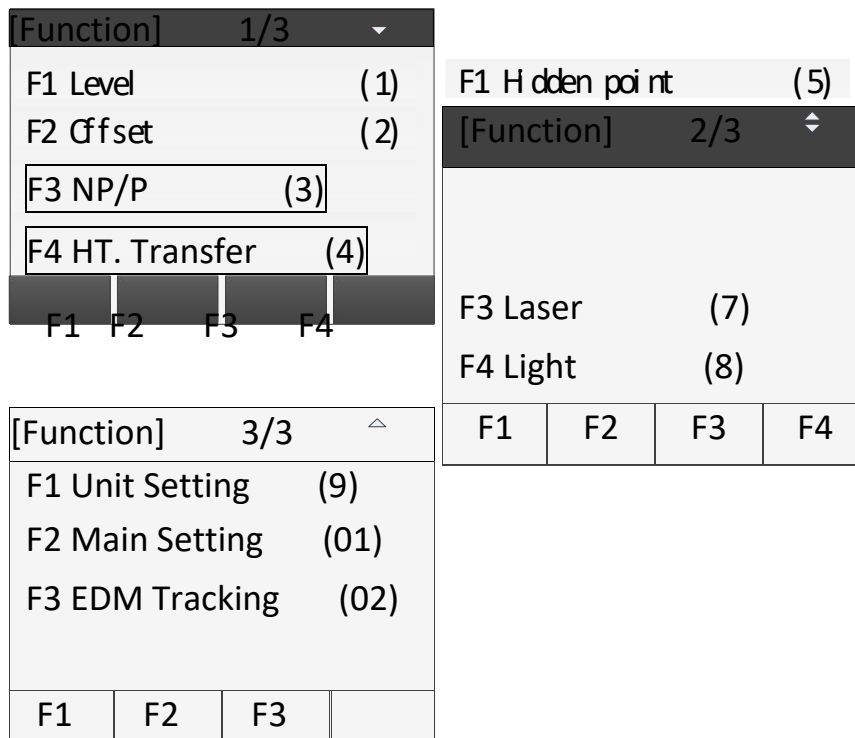

You can open Function menu to select the function you want to use, you can also define the function which on the Function menu to the key of [USER1] or [USER2], then press the key of [USER1] or [USER2] to use these functions.

## 1. Level

When the compensator is on, Compensator can compensate to the tilt caused by the instrument is not level. Manually level the instrument with the tribrach screws to make the compensation value of compensator tend to 0, by doing these can make the instrument tend to level. When the instrument is level, the laser plummet is in the direction vertical, the place of laser points is the place of instrument station.

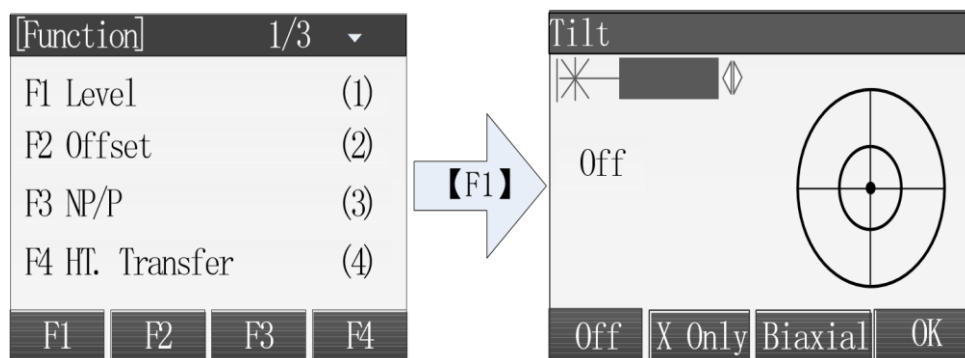

▲ Press [On] to open the compensator and press [Off] to close the compensator.

- ▲ Press [X Only] to open the compensator of X direction.
- ▲ Press [▲][▼] to adjust the laser plummet brightness.
- ▲ Press [OK] to close the laser plummet and exit.

## 2. Offset

The Offset is used to measure the points which are not intervisible, or intervisibility but can not set up prism in the Station.

Offset contains Dist. Offset and two subprograms, the two subprograms are Cylinder Offset and Angle Offset.

### 2.1 Distance Offset

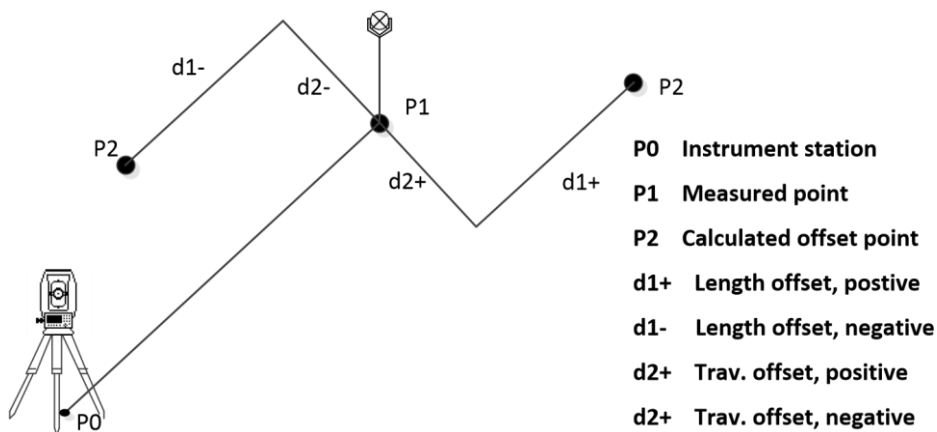

Using the external tools to measure the Offset values of the target point p2 and measurement point p1 along the line of station point and measurement point, the Offset values are Trav.OFS, LengthOFS and HeighOFS. Combining the information of measuring point (p1) can calculate the distance of station point (p0) to target point (p2), can also calculate the angel and coordinate.

When the measurement point is set on the left of target point or the right of target point, you should make the angle that between line of measurement point and target point and the line of measurement and station point about equals 90°. When the offset point is set on the front of target point or on the back of target point, you should make it on the line of station point and target point.

Steps	Key	Display
	[F2]	[Function] 1/3 ▾

O1 In the program of Q-Survey, press [FNC] to open the menu of Function, next pressing [F2] to enter the program of Offset.

F1 Level (1)			
F2 Offset (2)			
F3 NP/P (3)			
F4 HT. Transfer (4)			
F1	F2	F3	F4

O2 Input the values of Trav.OFS, LengthOFS and HeightOFS, then select the mode of offset and press [F4] to save.<sup>1</sup>

[F4]	[Dist. Offset]		
	Input offset data!		
	Trav.OFS :	0.00 0 m	
	Length	0.00 0 m	
	OFS:	0.00 0 m	
	Height		
	OFS:	Rec/Re set	
	Mode :	↕	
	Reset	Cylinde	Angle
		r	OK

<sup>1</sup>:  
 Rec/Reset: Make sure the inputed values of Offset and reset all the values of Offset to 0 after once measurement.  
 Permanent: The values of Offset are always working in the calculation of measurement point.

## 2.2 Cylinder Offset

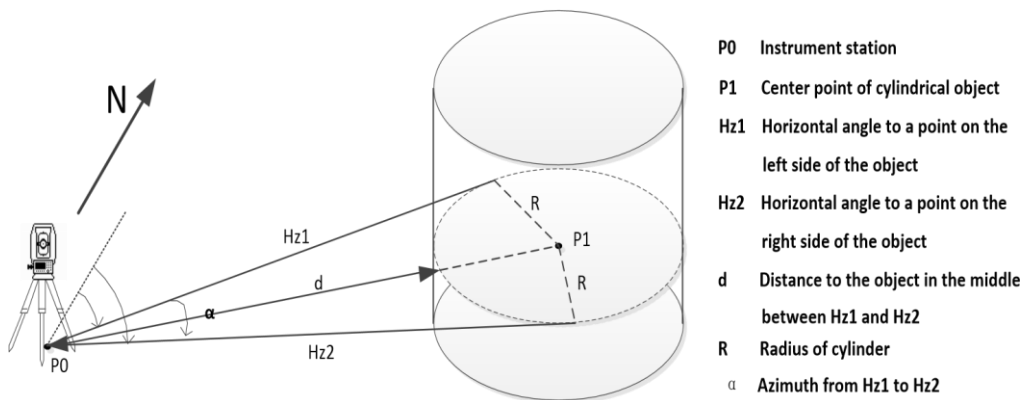

As for the not intervisible cylinders, you can measure the angles of station point with cylinder in Hz Left and Hz Right and the shortest distance of station point to cylinder firstly. Then calculate the coordinate of cylinder center and radius of cylinder through the geometric relationships. The shortest distance between station point and cylinder is in the bisector of angle of station point with cylinder in Hz Left and Hz Right.



Turning the instrument to make the collimation axis in the bisector of angle that

station point with cylinder in Hz Left and Hz Right, thus can measure the distance between cylinder and station.

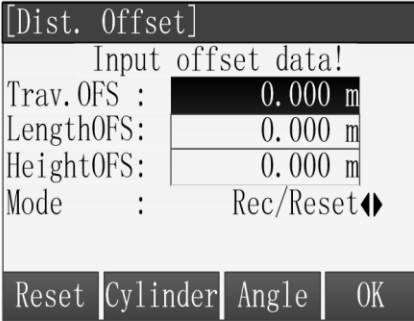
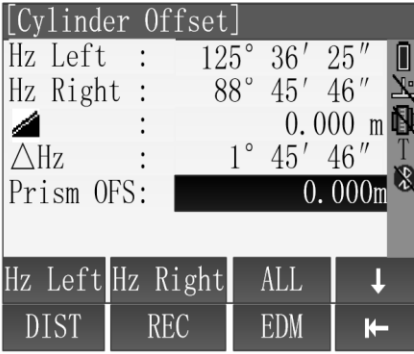
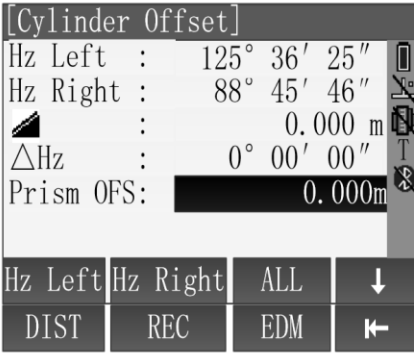
Steps	Key	Display
<p>① In the program of Q-Survey, press [FNC] to enter the menu of Function, then pressing [F2] to enter the program of Offset.</p>	[F2]	
<p>② Press [F2] to enter the subprogram of Cylinder Offset.</p>	[F2]	
<p>③ Aim at the left edge of cylinder, press [F1] to make sure the angle of Hz Left, turn the instrument to aim at the right edge of cylinder and press [F2] to make sure the angle of Hz Right.</p>	[F1]+[F2]	
<p>④ Turn the instrument to make <math>\Delta</math>Hz=0, if use the prism, please input the thickness of prism in the edit text of PrismOFS, if don't use the prism, the default value is 0 in the edit of PrismOFS, then press [F3] to measure the shortest distance of the instrument to cylinder</p>	[F3] or [F4] + [F1]+[F2]	



and enter the interface of Cylinder Offset-Result.		
O5 Display the result of cylinder offset.		<div style="border: 1px solid black; padding: 5px;"> <p>[Cylinder Offset-Result]</p> <p>Pt : 1</p> <p>Note :</p> <p>N : 12.215m E : 25.325m Z : 0.000m</p> <p>Radius : 8.125m</p> <p>Done <input type="button" value="New"/></p> </div>

### 2.3

### Angel Offset

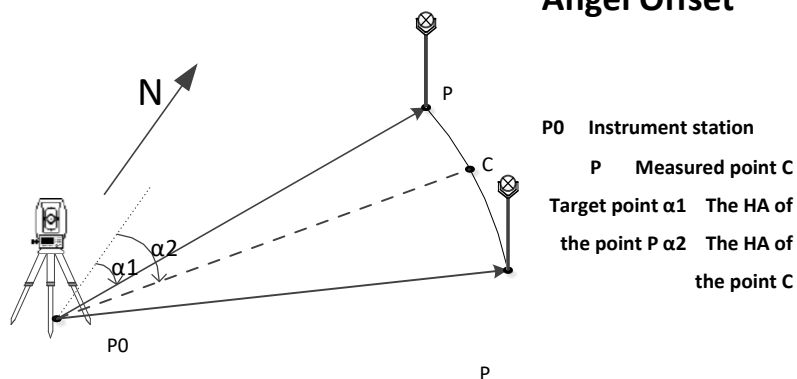

Angle Offset is used to measure the points which are intervisible but have no reflector and can't set up the prism. The basic principle is making the target point and measurement point in the concentric circles whose center is station point, then measurement the position information of station point and measurement point and the angle offset of station to target point, thus can calculate the coordinate of target point.

Set the measurement point P in the place where is as far as possible to close the left or right of target point C, and make the distance between measurement point P and station point A and the distance between station point A and target point C are approximately equal.

Steps	Key	Display
-------	-----	---------

<p>○1 In the program of Q-Survey, press [FNC] to enter the menu of Function, then pressing [F2] to enter the program of Offset.</p>	<p>[F2]</p>	<p>[Function] 1/3</p> <p>F3 NP/P (3)</p> <p>F4 HT. Transfer (4)</p> <p>F1 F2 F3 F4</p>
<p>○2 Press [F3] to enter the subprogram of Angel Offset.</p>	<p>[F3]</p>	<p>[Dist. Offset]</p> <p>Input offset data!</p> <p>Trav.OFS : 2.000 m</p> <p>LengthOFS: 1.000 m</p> <p>HeightOFS: 0.000 m</p> <p>Mode : Rec/Reset</p> <p>Reset Cylind Angle OK</p>
<p>○3 Aim at the measurement point and press [F1] to measure distance.</p>	<p>[F1]</p>	<p>[Angle Offset]</p> <p>Pt. : T.H. 1</p> <p>: HA : 1.550m</p> <p>VA : 89°51' 16"</p> <p>- : 12°35' 45"</p> <p>12.235m</p> <p>DIST OK</p>
<p>○4 Aim at the target point and press [F4] to make sure the direction of target point, next enter the program that displaying the result of angle measurement.</p>	<p>[F4]</p>	<p>[Angle Offset]</p> <p>Pt. : T.H. 1</p> <p>: HA : 1.550m</p> <p>VA : 89°51' 16"</p> <p>- : 12°35' 45"</p> <p>12.235m</p> <p>DIST OK</p>

<p>O5 Display the result of angle Offset.</p>		<div data-bbox="863 367 1342 719"> <p>[Angle Offsets] 1 ▾ /2</p> <p>Pt : 1</p> <p>Note : N</p> <p>: E : 5.154 m</p> <p>Z : 4.465 m</p> <p style="text-align: right;">2.348 m</p> <p>Done <input type="text"/> <input type="text"/> New</p> </div> <div data-bbox="863 763 1342 1234"> <p>[Angle Offset] ▲</p> <p>2/2</p> <hr/> <p>Pt. : Note 1</p> <p>:</p> <p>HA : ΔHz 123°36' 32"</p> <p>: — : 12°35' 45"</p> <p style="text-align: right;">12.235 m</p> <p>Done <input type="text"/> <input type="text"/> New</p> </div>
---	--	---

### 3. NP/P Toggle

Switch the mode of reflector quickly. (P is the mode of Prism and NP is the mode

of Non-Prism)

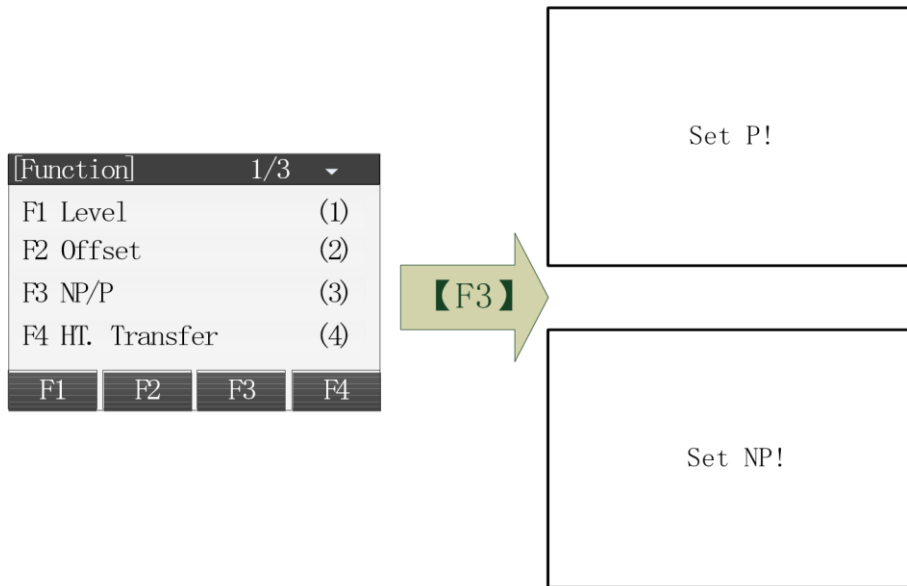

Open the first page of Function Menu and press [F3] to switch the mode of reflector.

### 4. Height Transfer

The functions of HT. Transfer as follows: Using the measurement data of target point, the fixpoints, fix measurement points and so on to calculate the height of current station point and set the height of station again. You can receive the coordinate of target point by calling the points in the file or through the keyboard to input, you can observe 5 fixpoints' height at most and to calculate.

The principle of Height Transfer:

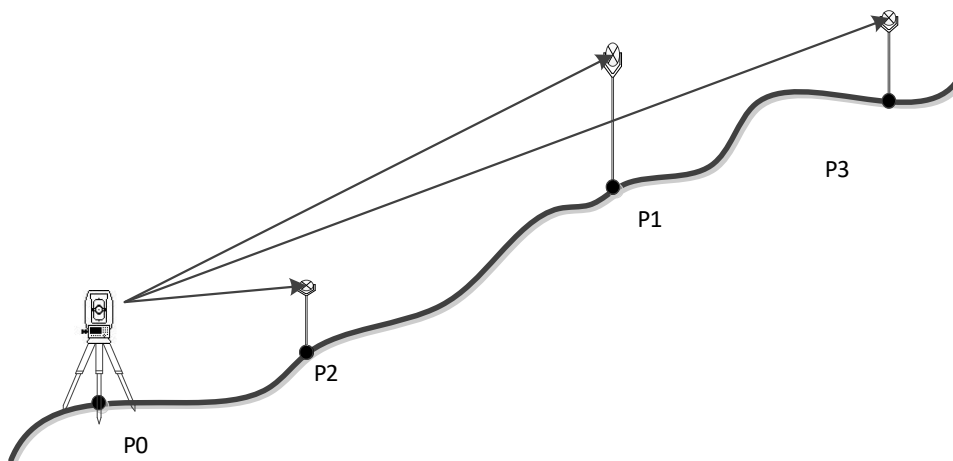

- P0 Station point
- P1~P3 Target fixpoints height

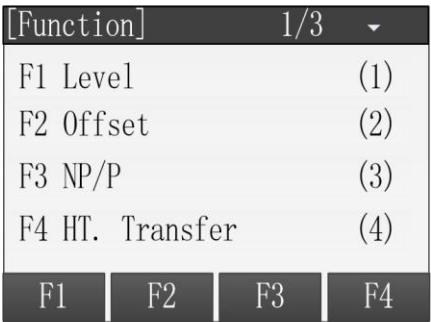
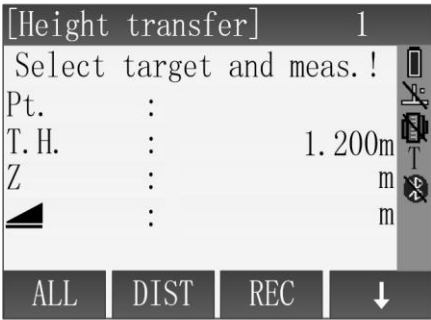
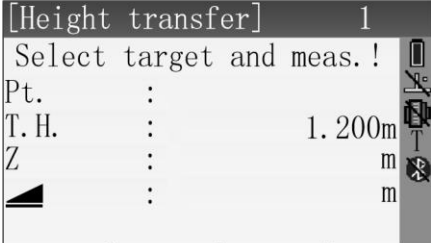
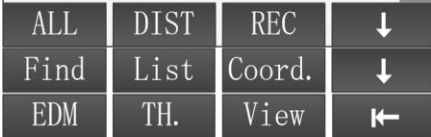
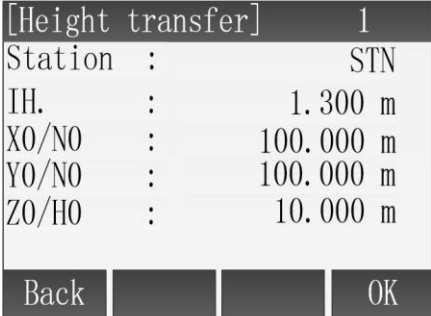
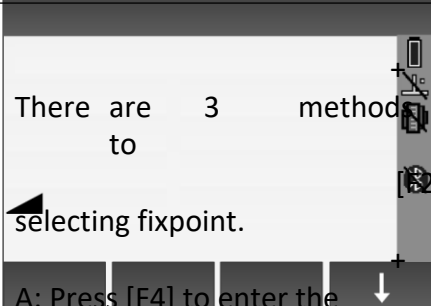
Steps	Key	Display
<p>① Press [F4] or [4] in the first page of [Function] to enter the function of Height Transfer measurement.</p>	<p>[F4] or [4]</p>	 
<p>② Press [F4] twice and display the third page of soft keys, press [F2](IH)to enter the function of setting instrument height, inputting the current instrument height and press [F4] to back to the function of Height Transfer interface.</p>	<p>[F4] + [F4] + [F2] + [F4]</p>	  
<p>○3 Select the fixpoint and input the height of Prism. The numbers of measured fixpoints are displayed in the [F4] top right corner.</p>		

[F4]  
 second page of soft key and press  
 [F2](List) .In the dialog of [Find Pt.], by  
 pressing [▲] or [ ▼] to select the  
 fixpoints to call.  
 [ H eight transfer] 1 Select  
 target and meas.!  
 Pt. : Pt.1  
 T.H. : 21..520000m m T Z :  
 \_ : m

A: [List]  
 [ F ind Pt.] 1/50  
 DEFAULT Station  
 STN1 Station  
 200007 Meas. PT  
 200008 Meas. PT  
 View Coord. Job OK

ALL DIST REC  
 B: Input the name of point and  
 press [F1] (View) to view the  
 point whether exists in the file  
 or not. If exists, you can call it,  
 otherwise, you need to input  
 or measure the coordinate of

[F1]  
 (View)  
 +  
 [F4]  
 (OK)

the point.  
 B: Search point  
 [ F ind Pt.] 1/3  
 1 Station

Press [F2] (Coord.) and input  
 a point name which not exists  
 in the file.

[F3] C:  
 (Coord)  
 +  
 [F4]

View Coord. Job OK  
 Job : DEFAULT  
 Pt. : DEFAULT N :  
 0.000m E : 0.000m  
 Z : 0.000m

C: Input point  
 [ I nput Coord.]

Back  
 OK

O4 After finishing setting up  
 the fixpoint, the height of Pt.  
 fixpoint is displayed in the T.H.  
 [F1](ALL)or Z :

[ H eight transfer] 1  
 [F1] Select target and meas.!  
 : Pt.1  
 or  
 :  
 [F2] screen and press

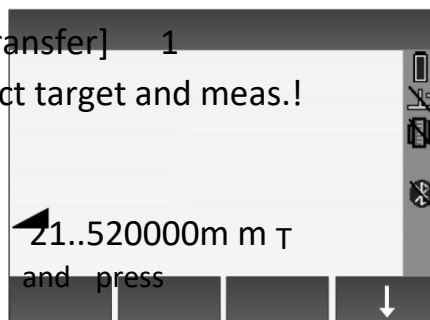

[F2](DIST)+[F3](REC) to start to [F3]

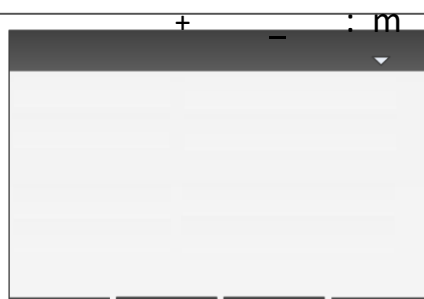

---

measure and calculate, the ALL DIST REC height of station is calculated.

[ H eight transfer res.]

○5 In the interface of [Height

Station : STN ZO/HO :  
0.781 m

Transfer Result], pressing

Correc. : 0.000 m

[PAGE] to switch the display of

PT NUM. : 1 result information.

Press [F1](Add PT) to add a

Back

new point and to start a new [PAGE]

measurement. [ H eight transfer res.]

Station : STN

Press [F3](Back) to back to XO/N0 : 0.081 m measure the current point

YO/E0 : 0.081 m again. ZO/HO : 0.081 m

PT NUM. : 1

Press [F4](OK)to enter the

Errors : 0.000 m

interface of [Set STA HO].

Back

○6 Pressing [F1] to back to the

interface of [Height Transfer

[

Result]. S et STA HO]

Station : STN

Press [F2] to set the height of

station to the old value Old HO : 0.781 m Press [F4] to set the height of New

HO : 0.781 m

$\Delta$ HO : 0.781 m

station to the new value which

calculated after Height Transfer. Back OLD AVG

Press [F3] to set the height of [station to the average of the old value and new value

---

---

## **5. Hidden Point**

The function of Hidden Point is using a special hidden point measuring rod to measure the points which are not intervisible.



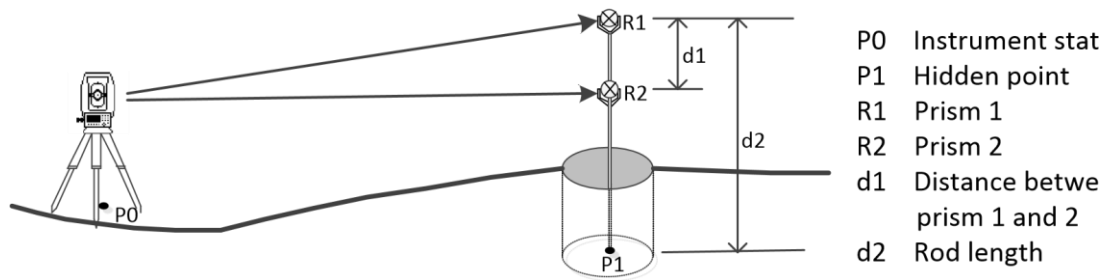

The length of measuring rod is known, by measuring the position information of prism 1 and prism 2 in the measuring rod and using mathematical methods to calculate the coordinate of hidden point on the other side of the measuring rod.

Steps	Key	Display
① In the program of Q-Survey, press [FNC] to enter the menu of Function, then pressing [PAGE] to open the second page of Function and then pressing [F1] to enter the function hidden point measurement.	[F1]	
② In the interface of measuring the first prism point, pressing [F4] to enter the interface of Rod Length.	[F4]	
③ Inputting the correct value of Rod length and pressing [F4] to back to measure the first prism point.	[F4]	
○4 The instrument aims at the prism on the top and	[F1] or	

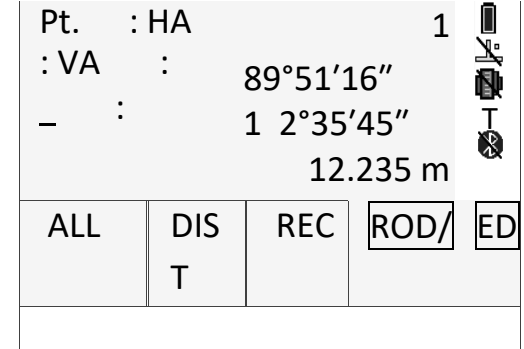
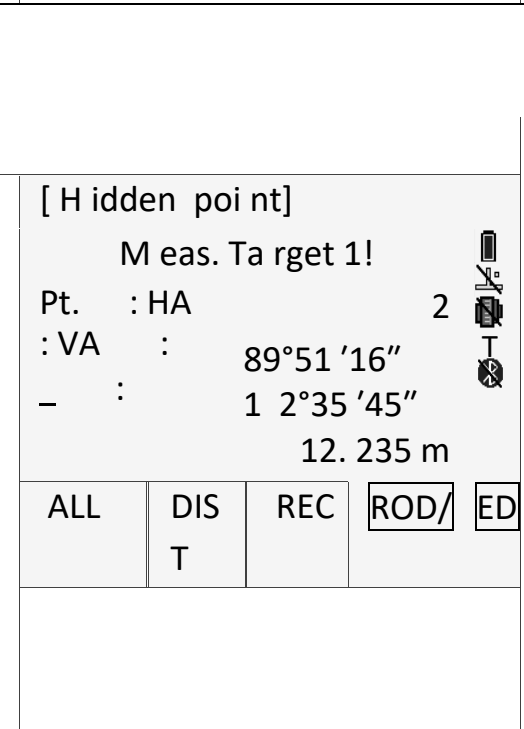
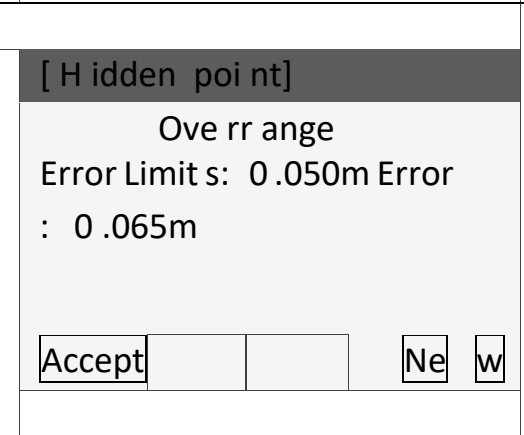
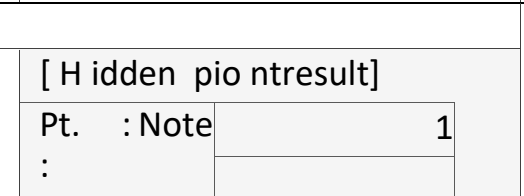
<p>pressing [F1] to finish measuring the first prism and enter the interface of measuring the second prism.</p>	<p>[F2] + [F3]</p>	
<p>○5 Aim at the second prism and press [F1] to finish the second prism's measurement. Start to calculate the information of hidden point now. If the error is beyond the set value, enter the step○6 of giving a prompt of error, otherwise, enter step○7 to display the result of hidden point measurement.</p>	<p>[F1] or [F2] + [F3]</p>	
<p>○6 A prompt of error. Press [F1] to enter the step○7 to display the result of hidden point measurement, press [F4] to back to the step○2.</p>	<p>[F1] or [F4]</p>	
<p>○7 Display the result of hidden point measurement.</p>		

		N : E	4 .325m
		:	4 .365m
		Z :	2 .235m
	Done		New

## 6. Free Coding

Please refer to “3. Q-Survey” → “3. Start Measurement” → “3.4 Code”

## 7. Laser Pointer

Open or close the laser fastly.

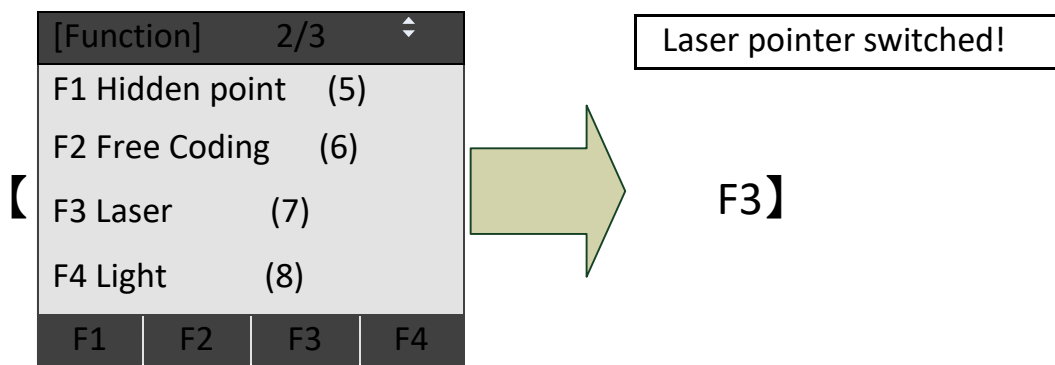

## 8. Light

Turn on or off the light of instrument screen fastly.

[Function]	2/3	⌵
F1 Hidden point	(5)	
F2 Free Coding	(6)	
F3 Laser	(7)	
F4 Light	(8)	
F1	F2	F3
F4		

Open the second page of Function Menu and press [F4] to turn on or off the Light.

## 9. Unit Setting

Set the common Unit fastly.

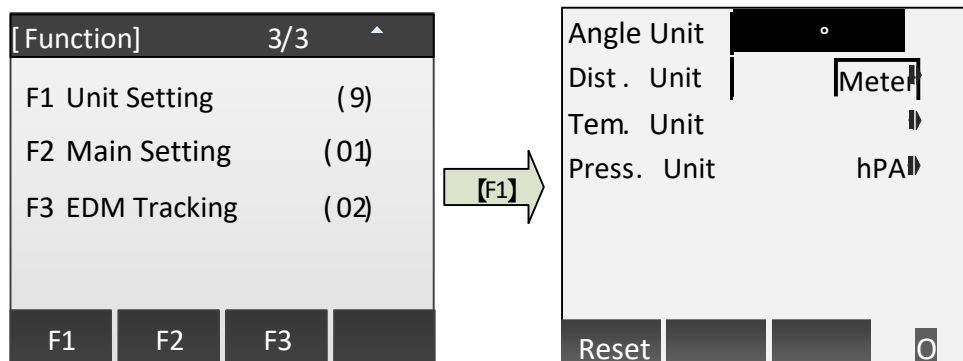

Open the third page of Function Menu and press [F1] to enter the interface of unit setting. After finishing setting the units in the interface of Unit Setting, press [F4](OK) to save the settings, press [F1](Reset) to restore all units to factory default.

## 10. Main Setting

Open the settings about instrument's hardware, the specific items as follows:

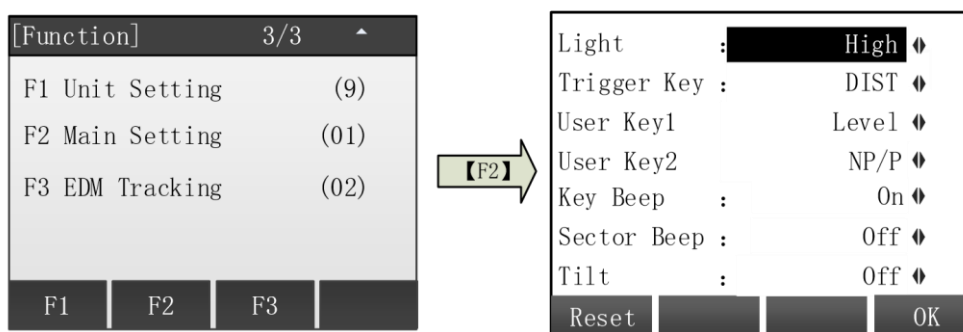

As for the setting of specific items , please refer to "General Setting".

---

## 11. EDM Tracking

Open or close the mode of EDM Tracking fastly.

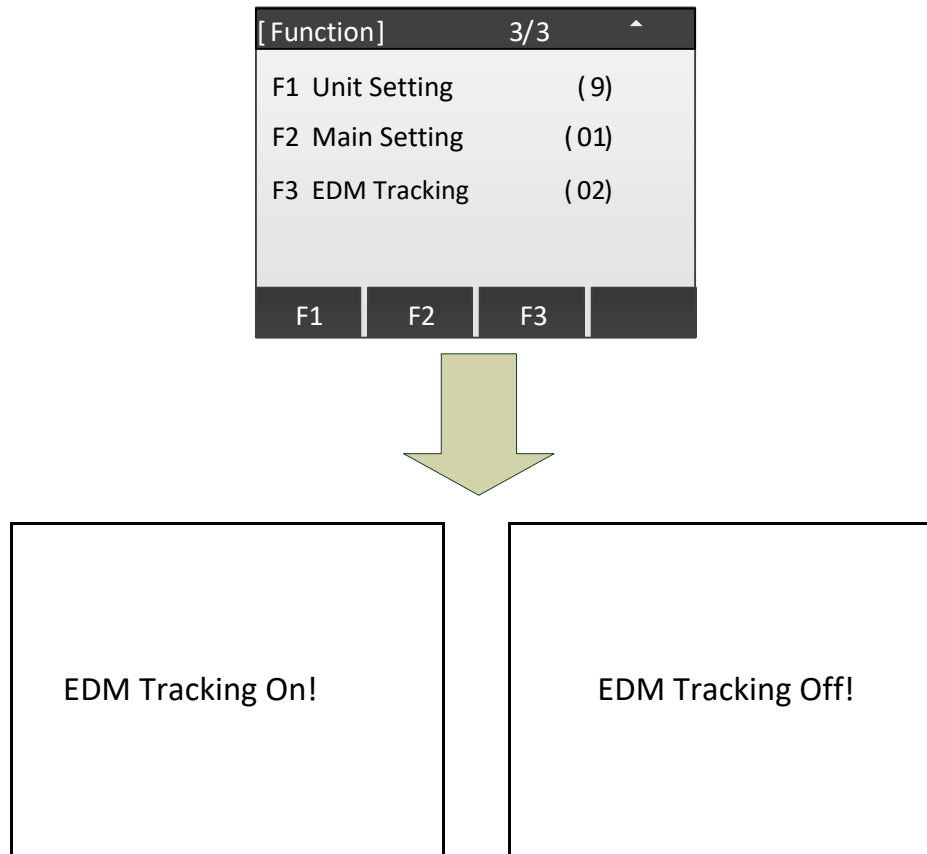

Open the third page of Function Menu, press [F3] to open or close the mode of EDM tracking.

## 5. Applications

Prepare setting before measuring:

Before starting the application, there are some preparations needed to set up. The Pre-Settings screen will be shown after the user selects an application. User can select and set the content of the Pre-Settings menu successively.

[Surveying]

[*]	F1	Set Job	(1)
[*]	F2	Set STA	(2)
[ ]	F3	Set B.S.	(3)
	F4	Start	(4)
F1	F2	F3	F4

[\*]: Setting has been done.

[ ]: Setting has not been done.

The details of every setting are as follows.

## 1. Setting the Job

The measured data and fix data are saved in the jobs which are shown as child directories. The job contains different types of data, such as fix points, measured points, station points, codes, etc. The data in the job can be read, edited and deleted.

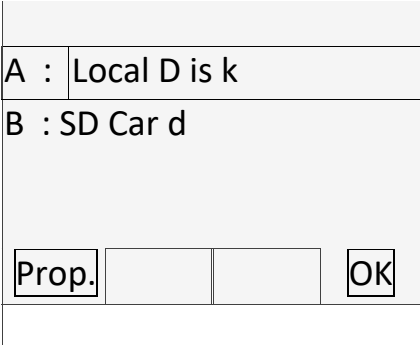
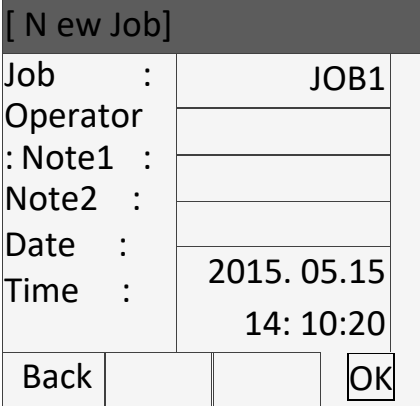
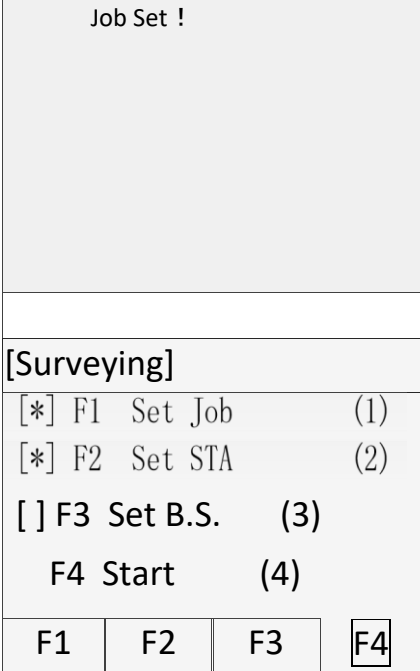

### 1.1 Create a new Job

Steps	Key	Display																				
<p>○1 Press [F1] in the Pre-Settings screen. Then enter the Set Job function.</p>	[F1]	<p>[Surveying]</p> <table border="1"> <tr> <td>[*]</td> <td>F1</td> <td>Set Job</td> <td>(1)</td> </tr> <tr> <td>[*]</td> <td>F2</td> <td>Set STA</td> <td>(2)</td> </tr> <tr> <td>[ ]</td> <td>F3</td> <td>Set B.S.</td> <td>(3)</td> </tr> <tr> <td></td> <td>F4</td> <td>Start</td> <td>(4)</td> </tr> <tr> <td>F1</td> <td>F2</td> <td>F3</td> <td>F4</td> </tr> </table>	[*]	F1	Set Job	(1)	[*]	F2	Set STA	(2)	[ ]	F3	Set B.S.	(3)		F4	Start	(4)	F1	F2	F3	F4
[*]	F1	Set Job	(1)																			
[*]	F2	Set STA	(2)																			
[ ]	F3	Set B.S.	(3)																			
	F4	Start	(4)																			
F1	F2	F3	F4																			
<p>○2 Press [F2](New) and then enter the Create a New Job screen.</p> <p>Press [F4](OK), the displayed job will be set as current job and then back to Pre-Settings screen.</p>	[F1]	<table border="1"> <tr> <td colspan="2">[ S et Job]</td> </tr> <tr> <td>Job :</td> <td>DEFAULT</td> </tr> <tr> <td>Operator :</td> <td></td> </tr> <tr> <td>Date :</td> <td>2015.05.15</td> </tr> <tr> <td>Time :</td> <td>14:10:20</td> </tr> <tr> <td>List</td> <td>Ne w</td> <td></td> <td>OK</td> </tr> </table>	[ S et Job]		Job :	DEFAULT	Operator :		Date :	2015.05.15	Time :	14:10:20	List	Ne w		OK						
[ S et Job]																						
Job :	DEFAULT																					
Operator :																						
Date :	2015.05.15																					
Time :	14:10:20																					
List	Ne w		OK																			
<p>○3 If the instrument is fitted with</p>		<table border="1"> <tr> <td>[ S elect Dis k]</td> <td></td> </tr> </table>	[ S elect Dis k]																			
[ S elect Dis k]																						

<p>SD Card, there will firstly show the disk selection screen. In this screen, user can select the disk through Up or Down key. Then press [F4](OK) to confirm.</p> <p>A: Local Disk B: SD Card</p>		
<p>O4 Continue to show New Job screen. Input the new job's name, operator, etc. Press [ENT] to finish one input item and the cursor moves to the next input item automatically at the same time. <sup>1</sup></p>	<p>job's Input data + [ENT]</p>	
<p>O5 Press [F4](OK) to complete setting a new job after finishing all the inputs. This job will be set as the current job. Then back to the Pre-Settings screen. The completed setting item is marked with [*].</p>	<p>[F4]</p>	
<p><sup>1</sup>: The instrument system will create and add date and time automatically.</p>		

## 1.2 Select an Existing Job from Memory

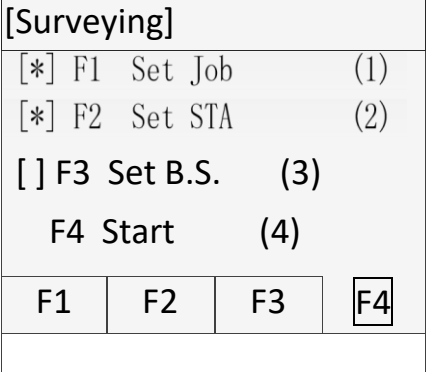
If there is any job existing in the memory, user can select this job and set it as the current job.

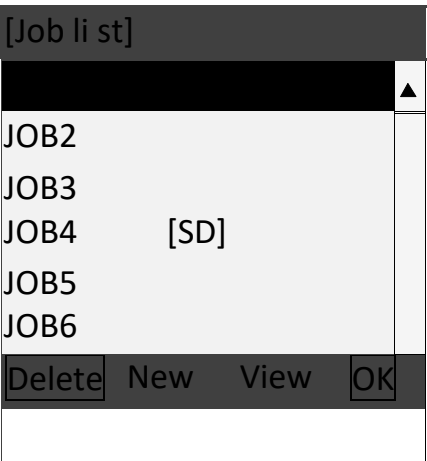
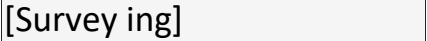
Steps	Key	Display
<p>○1 Press [F1] in the Pre-Settings screen. Then enter the Set Job function.</p>	[F1]	
<p>○2 Press [F1] (List) to enter Job list screen.</p>	[F1]	
<p>○3 All the existing jobs, including that stored on SD Card and will be shown as a list. The current job is marked with a *. Select the target job through Up and Down key and then press [F4](OK) to confirm the selection. The selected job is set as current job.</p>		
<p>○5 Back to Pre-Setting screen.</p>	[F4]	



The completed setting item is marked with \*.

[*]	F1	Set Job	(1)
[*]	F2	Set STA	(2)
[ ]	F3	Set B.S.	(3)
	F4	Start	(4)

F1	F2	F3	F4
----	----	----	----

Note: Don't pull out the SD Card when it is in operating state, otherwise it will cause the SD Card's data loss or damage.

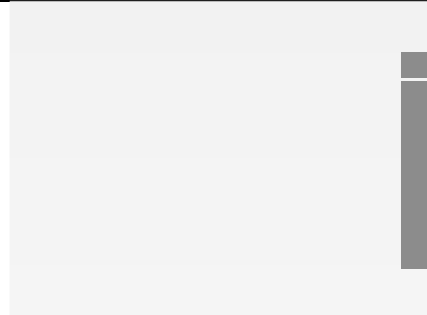

- All measured data are stored in the current job.
- If start the application without setting the job, press ALL key or press REC key in the Q-Surveying screen, the instrument system will create a job which named DEFAULT automatically.

## 2. Setting the Station

Every target coordinate's calculation is related to the position of the station. The station coordinate can be input manually or selected from the instrument memory.

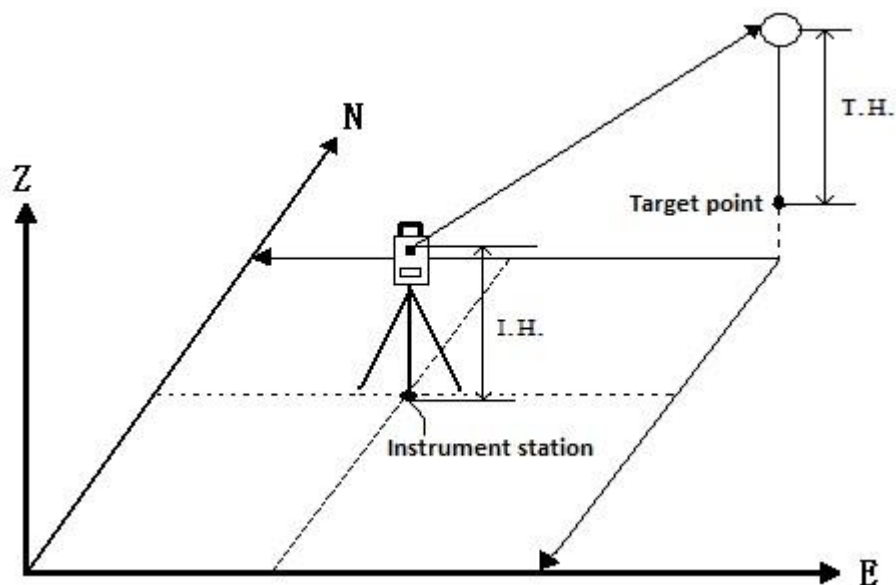

## 2.1 Select the coordinate from memory [Find]

Steps:

- 1、 Select the coordinate from memory.
- 2、 Input instrument height.
- 3、 [OK] Set station.

Steps	Key	Display
<p>○1 Press [F2] in the Pre-Settings screen. Then enter the Set STA function.</p>	[F2]	<div style="border: 1px solid black; padding: 5px;"> <p>[Surveying]</p> <p>[*] F1 Set Job (1)</p> <p>[*] F2 Set STA (2)</p> <p>[ ] F3 Set B.S. (3)</p> <p>F4 Start (4)</p> <p>F1   F2   F3   <span style="border: 1px solid black; padding: 2px;">F4</span></p> </div>
<p>○2 Input the name of the station point which exists in the job and then press [ENT]. ""<sup>1</sup></p>	Input point name + [ENT]	<div style="border: 1px solid black; padding: 5px;"> <p style="background-color: #cccccc;">[ Set STA ]</p> <p style="text-align: center;">Input STA PT!</p> <p>Station :           DEFAULT</p> <p style="text-align: center;">Find   List   <span style="border: 1px solid black; padding: 2px;">Coord.</span>  </p> </div>
<p>○3 Press [F1](Find):</p> <p><b>A:</b> If the input name exists in the current job, there will show the screens shown on the right figure. The multiple points with the same name will be sorted by type.</p> <p><b>B:</b> If the input name doesn't exist in the current job, the program prompts the message "Pt. not</p>		<p>A:</p> <div style="border: 1px solid black; padding: 5px;"> <p>[ Find Pt.]           1/5</p> <p>1           Stat ion</p> <p>A1         Stat ion</p> <p>A1         Meas . P T</p> <p>A1         Meas . P T</p> <p>A1         Targ et PT</p> <p>View   <span style="border: 1px solid black; padding: 2px;">Coord.</span>   Job   O K</p> </div>

found". Then enter the [Find Pt.] screen.

There can also select point from other jobs and set it as the station point. Input the point name and press [F4](Find). If the point is found, press [OK] in the [Find Pt.] list screen to set it as station. Program enter input instrument height screen. If the point doesn't exist, press [F3](Coord.) to input the coordinates of N, E and Z. Set this point as station.

**[Zero]:** Set this point's all coordinates as 0 and set the point as station.

**[Coord.]:** Enter [Input Coord.] screen. Input the coordinates and save them to the current job.

B:

[Find Pt.]			
Job : DEF AULT			
Pt. : Select	121		
job	or	input	
	coord	d.!	
Job	Zero	Coord.	Find

[Set STA]	
Job :	DEF AULT
Pt. :	121
N : E	0.000m
:	0.000m
Z :	0.000m
	0.000m
Back	OK

**O4** Enter input instrument height screen. Input the instrument height and press [ENT] to confirm. Then press [F4](OK) to save and set the station information.

Press [ESC] then back to previous screen. Continue to set the coordinates of station.

Input instrument height + [ENT] + [F4]

[Set STA]	
Input I.H!	
I.H. :	0.000m
Back	OK

**O5** Back to Pre-Settings screen.

[Survey ing]

The setting items that have been made are marked with *.		<div style="border: 1px solid black; padding: 5px;"> [*] F1 Set Job (1)  [*] F2 Set STA (2)  [ ] F3 Set B .S. (3)  F4 Start (4) </div> <div style="border: 1px solid black; display: flex; justify-content: space-around; margin-top: 5px;"> <span>F1</span> <span>F2</span> <span>F3</span> <span style="border: 1px solid black;">F4</span> </div>
<sup>1</sup> : The details of [Find Pt.] can be found in the chapter "Find Point". You can also input the wildcard "*" to search all the points.		

## 2.2 Select the Fix Point in the Memory [List]

User can select the fix point in the memory's jobs to set station without inputting the point name.

Steps	Key	Display
O2 Press [F2](List) in the [Set STA] screen.	[F2]	<div style="border: 1px solid black; padding: 5px;"> [ Set STA]    Input STA PT!   Station :    <div style="text-align: right;">A1</div> <div style="display: flex; justify-content: space-around; margin-top: 5px;"> <span>Find</span> <span>List</span> <span style="border: 1px solid black;">Coord.</span> <span></span> </div> </div>
O3 Show the point list all the fix points and measured points of the current job.		<div style="border: 1px solid black; padding: 5px;"> [ Find Pt.] 1/50   DEFAULT Station   STN1 Station   <div style="border: 1px solid black; display: flex; justify-content: space-between; margin: 2px;"> <span>200007</span> <span>Meas. PT</span> </div> 200008 Meas. PT   100 Fix Pt.   101 Fix Pt.    <div style="display: flex; justify-content: space-around; margin-top: 5px;"> <span>View</span> <span style="border: 1px solid black;">Coord.</span> <span>Job</span> <span>OK</span> </div> </div>
O4 Select the needed point		<div style="border: 1px solid black; padding: 5px;"> [ View]:    [ View C oord] </div>

through Up and Down key.  
 [View]: Show the information of this point.



[Coord.]: Input the coordinate data manually.

[Job]: Select data from another job.

Job :		DEF AULT	
Pt. :	A1		
N :	0. 000m		
E :	0. 000m 0.		
Z :	000m		
Date :	2015.0 5.15		
			OK

[Coord.] :

[Set ST A]	
Job :	DEF AULT
Pt. :	121
N : E	0. 000m
Z :	0. 000m
	0. 000m
Back	OK

Job]:

[Find P t.]	
Job : DEF AULT	
Pt. :	121
Select job	or input
	coord.
	d.!
Job	Zero
Coord.	Find

○5 After selecting needed point, press [F4](OK) and enter input instrument height screen. Complete all settings and then back to Pre-Settings screen.

[F4] input instrument height +  
 [ENT]  
 [F4]



[Set STA]	
Input I.H!	
IH. :	1.400m
Back	OK

## 2.3 Input the coordinates manually.

Steps:

1. Press [Coord.], enter input coordinate screen.
2. Input the point name and coordinates.
3. [OK] Save the station coordinates. And then input the instrument height.

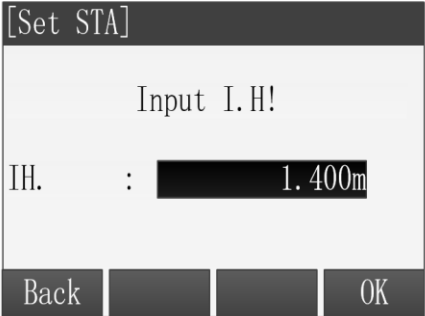
Steps	Key	Display								
<p>○2 Press [F3](Coord.) in the [Set STA] screen.</p>	[F3]	<div style="border: 1px solid black; padding: 5px;"> <p>[ Set STA ]</p> <p style="text-align: center;">Input STA PT!</p> <p>Station : <span style="float: right;">A1</span></p> <hr/> <p>Find   Lis t   Coord.   <span style="float: right;"> </span></p> </div>								
<p>○3 Input the point name and the point's coordinates. After inputting one item, the curser will move to next input item.</p>	<p>Input point name and coordinate + [ENT]</p>	<div style="border: 1px solid black; padding: 5px;"> <p>[ Input Coord . ]</p> <p>Job : DEF AULT</p> <table style="width: 100%; border-collapse: collapse;"> <tr> <td style="border: 1px solid black; width: 30%;">Pt. : N</td> <td style="width: 70%; text-align: right;">121</td> </tr> <tr> <td style="border: 1px solid black;">:</td> <td style="text-align: right;">3. 012m</td> </tr> <tr> <td style="border: 1px solid black;">E :</td> <td style="text-align: right;">15. 012m</td> </tr> <tr> <td style="border: 1px solid black;">Z :</td> <td style="text-align: right;">4. 125 </td> </tr> </table> <hr/> <p>Back   <span style="float: right;">O K</span></p> </div>	Pt. : N	121	:	3. 012m	E :	15. 012m	Z :	4. 125
Pt. : N	121									
:	3. 012m									
E :	15. 012m									
Z :	4. 125									
<p>○4 Press [F4](OK) to save the coordinates of this point.</p>	[F4]	<div style="border: 1px solid black; padding: 5px;"> <p>[ Input Coord . ]</p> <p>Job : DEF AULT</p> <table style="width: 100%; border-collapse: collapse;"> <tr> <td style="border: 1px solid black; width: 30%;">Pt. : N</td> <td style="width: 70%; text-align: right;">121</td> </tr> <tr> <td style="border: 1px solid black;">:</td> <td style="text-align: right;">3. 012m</td> </tr> <tr> <td style="border: 1px solid black;">E :</td> <td style="text-align: right;">15. 012m</td> </tr> <tr> <td style="border: 1px solid black;">Z :</td> <td style="text-align: right;">4. 125m</td> </tr> </table> <hr/> <p>Back   <span style="float: right;">O K</span></p> </div>	Pt. : N	121	:	3. 012m	E :	15. 012m	Z :	4. 125m
Pt. : N	121									
:	3. 012m									
E :	15. 012m									
Z :	4. 125m									

<p>⑤ Program prompts "Saved!" Then enter input instrument height screen. Input the instrument height and press [ENT] to confirm. Then press [F4](OK) to finish the setting.</p>	<p>Input instrument height + [ENT] [F4]</p>	
<p>⑥ Back to Pre-Settings screen. The setting items that have been made are marked with *.</p>		

### 3. Setting the Orientation

The orientation can be input manually or determined from points that are either measured or selected from the memory.

#### 3.1 Manual input orientation

Steps:

1. Press [F1] and enter manual input screen.
2. Input the azimuth, prism height and point name.
3. Press [F1](ALL) to start measuring and set the orientation.
4. Press [REC] to record the angle and orientation.

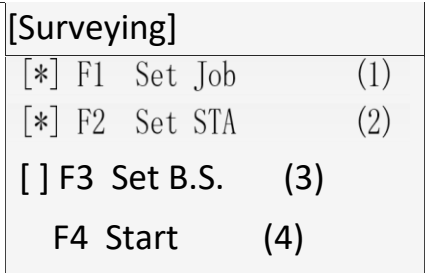
Steps	Key	Display
<p>○1 Press [F3] in the Pre-Settings screen. Then enter the Set STA function.</p>	<p>[F3]</p>	

		<table border="1"> <tr> <td>F1</td> <td>F2</td> <td>F3</td> <td>F4</td> </tr> </table>	F1	F2	F3	F4																								
F1	F2	F3	F4																											
<p>○2 Press [F1] and select the [Angle Setting] to input orientation manually.</p>	[F1]	<table border="1"> <tr> <td colspan="4">[Set B. S.]</td> </tr> <tr> <td>F1</td> <td>Angle Setting</td> <td>(1)</td> <td></td> </tr> <tr> <td>F2</td> <td>Coordinates</td> <td>(2)</td> <td></td> </tr> <tr> <td>F1</td> <td>F2</td> <td></td> <td></td> </tr> </table>	[Set B. S.]				F1	Angle Setting	(1)		F2	Coordinates	(2)		F1	F2														
[Set B. S.]																														
F1	Angle Setting	(1)																												
F2	Coordinates	(2)																												
F1	F2																													
<p>○3 Aim B.S. point and then input the azimuth, prism height and backsight point name. Press [ENT] after finishing every input.</p>	<p>Input horizontal angle + [ENT]</p>	<table border="1"> <tr> <td colspan="4">[Angle setting]</td> </tr> <tr> <td>Azimuth : T.H. :</td> <td>5 0°00'0</td> <td></td> <td></td> </tr> <tr> <td></td> <td>0"</td> <td></td> <td></td> </tr> <tr> <td>BS PT :</td> <td>1.50 0 m</td> <td></td> <td></td> </tr> <tr> <td></td> <td>DEFAU LT1</td> <td></td> <td></td> </tr> <tr> <td colspan="4">Ai m BS. Then ALL/ REC</td> </tr> <tr> <td>ALL</td> <td>REC</td> <td>Zero</td> <td>EDM</td> </tr> </table>	[Angle setting]				Azimuth : T.H. :	5 0°00'0				0"			BS PT :	1.50 0 m				DEFAU LT1			Ai m BS. Then ALL/ REC				ALL	REC	Zero	EDM
[Angle setting]																														
Azimuth : T.H. :	5 0°00'0																													
	0"																													
BS PT :	1.50 0 m																													
	DEFAU LT1																													
Ai m BS. Then ALL/ REC																														
ALL	REC	Zero	EDM																											
<p>○4 Press [F1](ALL) to start measuring and set the orientation. [REC]: Press this key to finish setting orientation without measurement. [Zero]: Set the azimuth as 0.</p>	[F1]	<table border="1"> <tr> <td colspan="4">BS SET !</td> </tr> </table>	BS SET !																											
BS SET !																														



<p>○5 Back to Pre-Settings screen.</p> <p>The setting items that have been made are marked with *.</p>	[Surveying]			
	[*] F1 Set Job (1) [*] F2 Set STA (2) [ ] F3 Set B.S. (3) F4 Start (4)			
	F1	F2	F3	F4

### 3.2 Set orientation with coordinates

The determination of the direction value can also be carried out using a point with a known coordinate.

Steps:

1. Press [F2] to go to set orientation with coordinates 2.  
Input the name of orientation point and find the point.
3. Input the prism height and determine it.
4. Use this point to set orientation.

➤ The orientation point can be select from memory or inputted manually.

Steps	Key	Display
<p>○1 Press [F2] to select Coordinate to Set orientation with coordinates.</p>	[F2]	<div style="border: 1px solid black; padding: 5px;"> [Set B.S.]  F1 Angle Setting (1)  F2 Coordinates (2) </div> <div style="display: flex; justify-content: space-around; margin-top: 5px;"> <span style="border: 1px solid black; padding: 2px;">F1</span> <span style="border: 1px solid black; padding: 2px;">F2</span> <span style="border: 1px solid black; padding: 2px;"> </span> <span style="border: 1px solid black; padding: 2px;"> </span> </div>
<p>○2 Find, select or input the backsight point coordinates and then go to the Meas. BS screen.</p>	Find, select or input the backsight point	<div style="border: 1px solid black; padding: 5px;"> [Set BS ]    Input BS PT!    BS PT : <span style="border: 1px solid black; padding: 2px 10px;">DEFAU LT1</span> </div>

---

		Find	List	Coord.	

## 4. Starting the Applications

The preset applications covers a wide range of measurement tasks. That makes the daily field measurement easier and faster. The all applications can be selected to use are as follows: ● Surveying

- Stakeout
- Free Station
- Tie Distance
- Area
- Remote Height
- COGO
- Road

Steps:

1. Go to the MAIN MENU.
2. Move the focus to [Program] or press the Numeric key 2 to select and go to the PROGRAM MENU.
3. Press [PAGE] to browse the application menu. Press [F1]-[F4] to select and start an application.

## 5. Surveying

Compared with the Q-Surveying, Surveying has different guides in setting station and set orientation.

<p>○3 Aim backsight point and then press [ENT].</p> <p>Press [F1](ALL) or press [F2](DIST) and [F3](REC) to start measuring and finish setting orientation. User can also press [F3](REC) to finish setting orientation without measurement.</p> <p>Press the [PAGE] key to switch the display of measured values screen and backsight inspection values screen.</p> <p>[EDM]: Go to set EDM settings.</p>	<p>[ENT]</p> <p>[F1]</p> <p>or</p> <p>[F2]、[F3]</p>	<div style="border: 1px solid black; padding: 5px;"> <p>Meas. BS ▾</p> <p style="text-align: center;">Aim BS PT! Press ENT continue</p> <table border="1" style="width: 100%; border-collapse: collapse;"> <tr> <td style="width: 25%;">ALL</td> <td style="width: 25%;">DIST</td> <td style="width: 25%;">REC</td> <td style="width: 25%;">EDM</td> </tr> </table> </div> <div style="border: 1px solid black; padding: 5px;"> <p>M e a s . B S ▾</p> <table style="width: 100%; border-collapse: collapse;"> <tr> <td style="width: 15%;">BS PT</td> <td style="width: 10%;">: :</td> <td style="width: 45%;">DEFA ULT1</td> <td style="width: 10%; text-align: right;"></td> </tr> <tr> <td>T.H.</td> <td>:</td> <td style="border: 1px solid black; text-align: center;">1.5 00 m</td> <td style="text-align: right;"></td> </tr> <tr> <td>HA</td> <td>: :</td> <td style="border: 1px solid black; text-align: center;">4 5°00' 00"</td> <td style="text-align: right;"></td> </tr> <tr> <td>Code</td> <td>:</td> <td style="border: 1px solid black; text-align: center;">4 5°00' 00"</td> <td style="text-align: right;"></td> </tr> <tr> <td></td> <td></td> <td style="text-align: center;">10.0 00 m</td> <td></td> </tr> <tr> <td></td> <td></td> <td style="text-align: center;">1.7 26 m</td> <td></td> </tr> </table> <table border="1" style="width: 100%; border-collapse: collapse;"> <tr> <td style="width: 25%;">ALL</td> <td style="width: 25%;">D I S T</td> <td style="width: 25%;">R E C</td> <td style="width: 25%;">E D M</td> </tr> </table> </div> <div style="border: 1px solid black; padding: 5px;"> <p>M e a s . S ▴</p> <table style="width: 100%; border-collapse: collapse;"> <tr> <td style="width: 15%;">B</td> <td style="width: 10%;">: :</td> <td style="width: 45%;">DEFA ULT1</td> <td style="width: 10%; text-align: right;"></td> </tr> <tr> <td>BS PT</td> <td>:</td> <td style="border: 1px solid black; text-align: center;">1.5 00 m</td> <td style="text-align: right;"></td> </tr> <tr> <td>HA</td> <td>: :</td> <td style="border: 1px solid black; text-align: center;">45°00' 00"</td> <td style="text-align: right;"></td> </tr> <tr> <td></td> <td></td> <td style="text-align: center;">10.0 00 m</td> <td></td> </tr> <tr> <td></td> <td></td> <td style="text-align: center;">1.7 26 m</td> <td></td> </tr> </table> <table border="1" style="width: 100%; border-collapse: collapse;"> <tr> <td style="width: 25%;">ALL</td> <td style="width: 25%;">D I S T</td> <td style="width: 25%;">R E C</td> <td style="width: 25%; border: 2px solid black;">E D M</td> </tr> </table> </div>	ALL	DIST	REC	EDM	BS PT	: :	DEFA ULT1		T.H.	:	1.5 00 m		HA	: :	4 5°00' 00"		Code	:	4 5°00' 00"				10.0 00 m				1.7 26 m		ALL	D I S T	R E C	E D M	B	: :	DEFA ULT1		BS PT	:	1.5 00 m		HA	: :	45°00' 00"				10.0 00 m				1.7 26 m		ALL	D I S T	R E C	E D M
ALL	DIST	REC	EDM																																																							
BS PT	: :	DEFA ULT1																																																								
T.H.	:	1.5 00 m																																																								
HA	: :	4 5°00' 00"																																																								
Code	:	4 5°00' 00"																																																								
		10.0 00 m																																																								
		1.7 26 m																																																								
ALL	D I S T	R E C	E D M																																																							
B	: :	DEFA ULT1																																																								
BS PT	:	1.5 00 m																																																								
HA	: :	45°00' 00"																																																								
		10.0 00 m																																																								
		1.7 26 m																																																								
ALL	D I S T	R E C	E D M																																																							
<p>○4 Back to Pre-Settings screen.</p> <p>The setting items that have been made are marked with *.</p>		<div style="border: 1px solid black; padding: 5px;"> <p>[Survey ing]</p> <table style="width: 100%; border-collapse: collapse;"> <tr> <td style="width: 15%;">[*] F1</td> <td style="width: 55%;">Set Job</td> <td style="width: 10%;">(1)</td> <td style="width: 20%;"></td> </tr> <tr> <td>[*] F2</td> <td>Set STA</td> <td>(2)</td> <td></td> </tr> <tr> <td>[ ] F3</td> <td>Set B.S.</td> <td>(3)</td> <td></td> </tr> <tr> <td>F4</td> <td>Start</td> <td>(4)</td> <td></td> </tr> </table> <table border="1" style="width: 100%; border-collapse: collapse;"> <tr> <td style="width: 25%;">F1</td> <td style="width: 25%;">F2</td> <td style="width: 25%;">F3</td> <td style="width: 25%;">F4</td> </tr> </table> </div>	[*] F1	Set Job	(1)		[*] F2	Set STA	(2)		[ ] F3	Set B.S.	(3)		F4	Start	(4)		F1	F2	F3	F4																																				
[*] F1	Set Job	(1)																																																								
[*] F2	Set STA	(2)																																																								
[ ] F3	Set B.S.	(3)																																																								
F4	Start	(4)																																																								
F1	F2	F3	F4																																																							

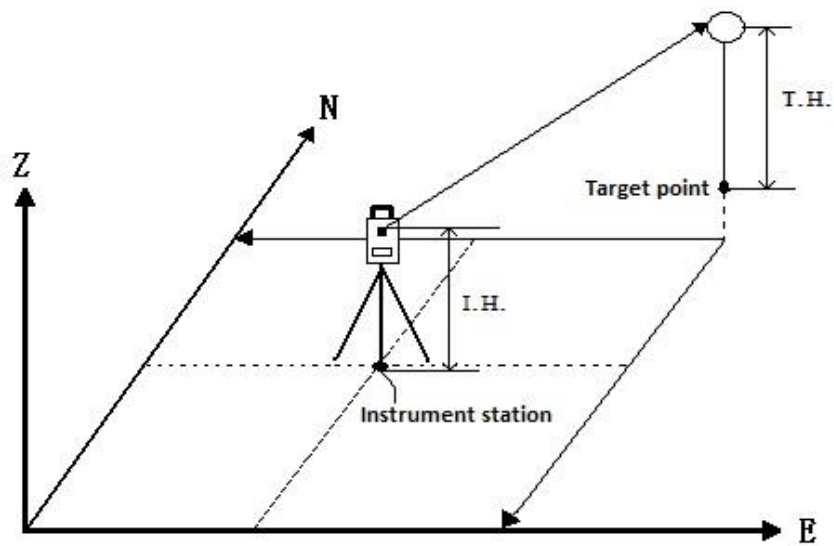

**Operation: Must first finish setting the station and orientation.**

Steps	Key	Display				
<p>O1 After finishing setting the job, setting the station and setting the orientation, press [F4] to start the application in the Pre-Setting menu.</p>	<p>[F4]</p>	<div style="border: 1px solid black; padding: 5px;"> <p>[Surveying]</p> <p>[*] F1 Set Job (1)</p> <p>[*] F2 Set STA (2)</p> <p>[ ] F3 Set B.S. (3)</p> <p>F4 Start (4)</p> <table border="1" style="width: 100%; text-align: center;"> <tr> <td>F1</td> <td>F2</td> <td>F3</td> <td style="border: 2px solid black;">F4</td> </tr> </table> </div>	F1	F2	F3	F4
F1	F2	F3	F4			

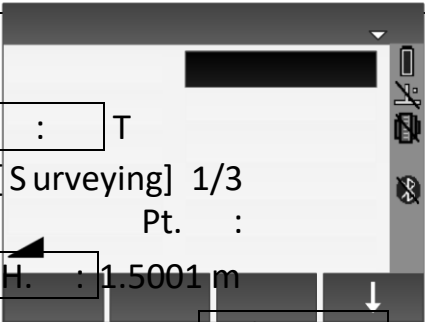
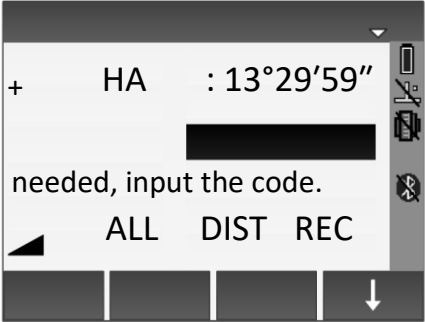
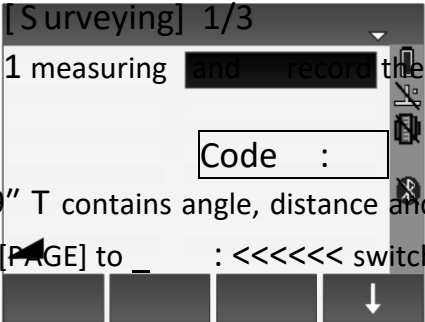
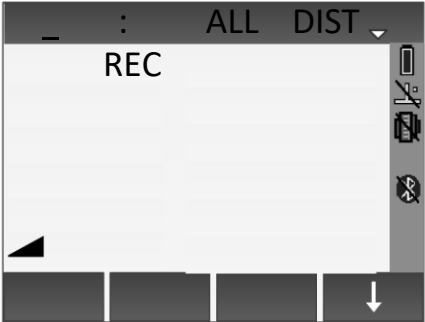
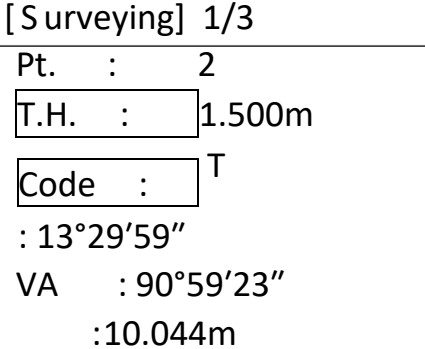
<p>○3 Input the prism height and</p>	<p>name Code : T</p> <p>Input prism height T.H. : 1.5001 m</p>	
<p>then press [ENT] to move the cursor to next input item. If VA</p>	<p>T</p> <p>: 90°59'23"</p> <p>[ENT] - : needed, input the code.</p>	
<p>○4 Press [F1](ALL) or press [F2](DIST) and [F3](REC) to start [F1] T.H. : 1.500m</p> <p>measured data. This data or HA : 13°29'59" T contains angle, distance and [F2]+[F3] VA : 90°59'23" coordinates. Press [PAGE] to switch the display mode of the ALL DIST REC data.</p>	<p>Pt. : 1 measuring</p> <p>Code :</p>	
<p>○2 Input the point name, and then press [ENT] to move to next input item to input prism height.</p> <p>Surveying] 1/3</p> <p>Pt. : 1</p> <p>Input point T.H. : 1.500m</p> <p>○5 After finishing measuring one point, the point name automatic</p>	<p>+ HA : 13°29'59"</p> <p>[ENT] VA : 90°59'23"</p> <p>- : ALL DIST REC</p> <p>[PAGE].</p>	
<p>plus one. Press [F1](ALL) or press [F2](DIST) and [F3](REC) to continue measuring next point. At this time, the screen remains the last measured data which can be looked over by pressing</p>	<p>[PAGE].</p> <p>HA : 13°29'59"</p> <p>VA : 90°59'23"</p> <p>- : 10.044m</p>	

---

---

ALL DIST REC

## **5.1 Individual Point**

### **[IndivPt]:**

In the data acquisition, point can be recorded individually. Press this key to switch the screens of Individual Point Measurement and Consecutive Point

Measurement.

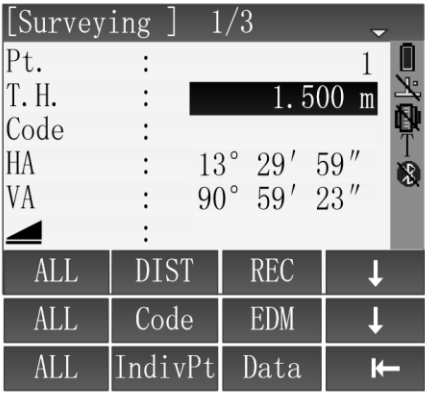
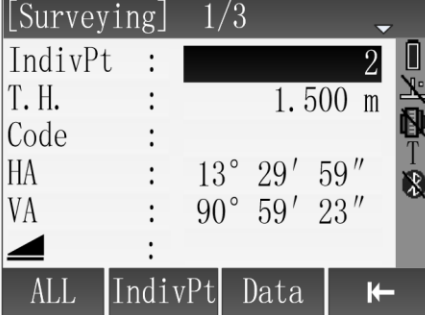
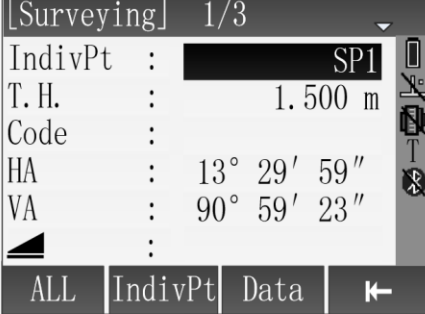
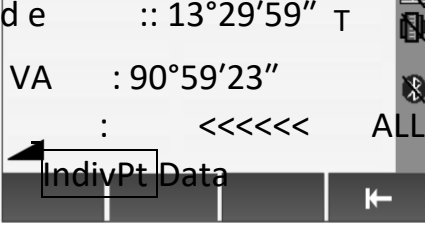
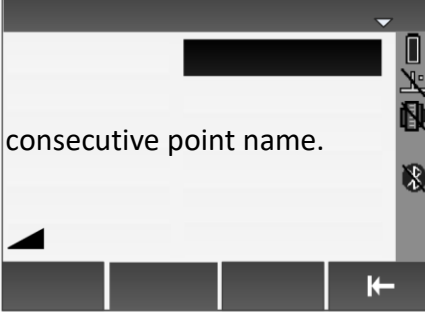
Steps	Key	Display
<p>① Press [F4](↓) twice to display the last page of soft keys.</p>	[F4]	
<p>② Press [F2](IndivPt) to start measuring individual point function.</p>	[F2]	
<p>③ Input the individual point's name and prism height and press [ENT] to move the cursor to next input item.. If needed, input the code.</p>	Input point name, prism height and code + [ENT]	
<p>④ Press [F1](ALL) or press [F2](DIST) and [F3](REC) to start measuring and record the measured data.</p>	or [F2]+[F3]	
<p>⑤ Finish measuring, application turn off the function of measuring individual point and then continue</p>	to display the consecutive point name.	

## 5.2 Data [Data]:

Look over the measured data which are saved in current job.

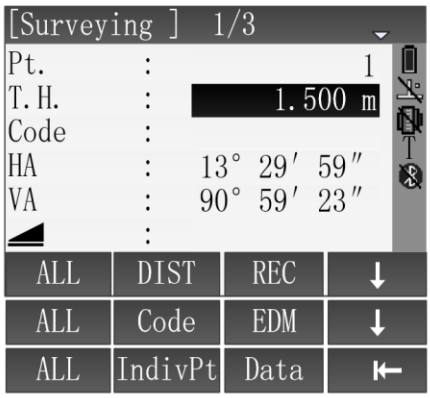
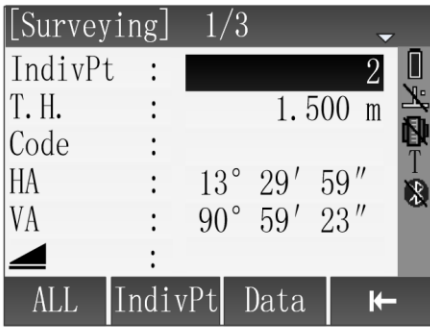



Steps	Key	Display
① Press [F4](↓) twice to display the last page of soft keys.	[F4]	
② Press [F3](Data) to start view measured point function.	[F3]	

```

[ S urveying] 1/3
  IndivPt :  2
  T.H.      :
            1.500 m

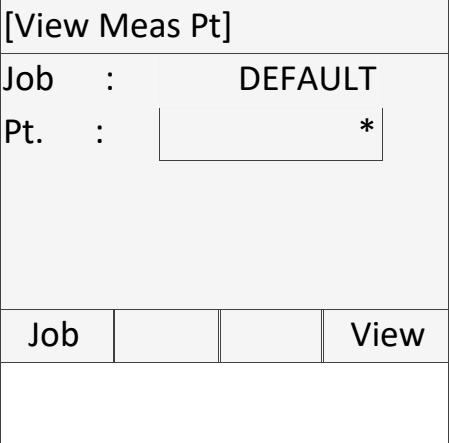
  CHoAd e   ::
13°29'59"  T VA  :
            90°59'23"
            :
- ALL IndivPt
  Data
  
```

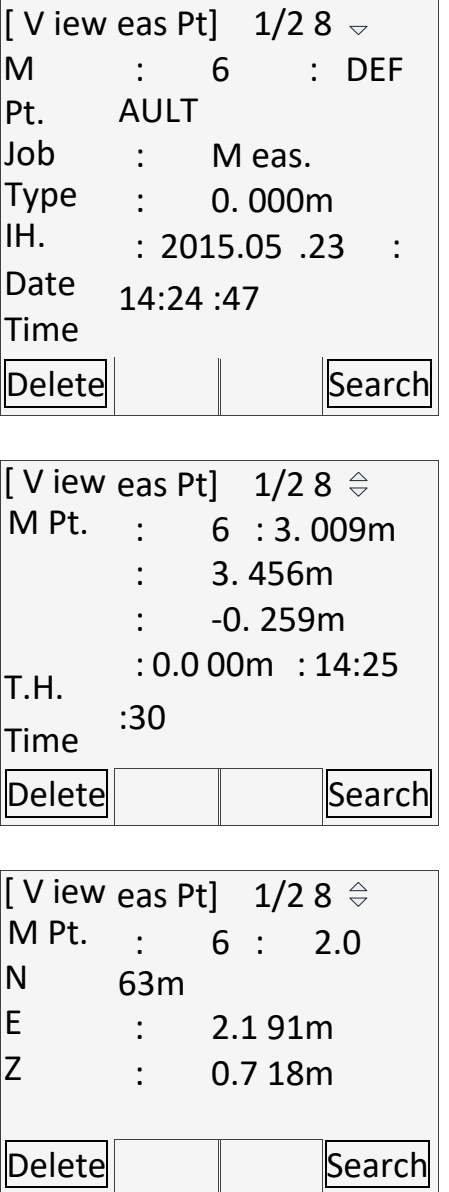

<p>○3 After inputting the target point's name or wildcard (*), press [ENT] and then press [F4](View) to look over the data. If there is no match point, the program prompts "<b>Pt. not found!</b>"</p> <p>[Job]: Select the job where the measured data is to be viewed.</p>	<p>Input point name/ wildcard + [ENT] + [F4]</p>	
<p>○4 Go to View Measured Point screen. Press [PAGE] to turn the page and look over all data field of this point. Press direction key  and  to browse the last or next measured point.</p> <p>[Delete]: Delete this point data. [Search]: Back to the Find Point screen.</p>	<p>[PAGE]  </p>	

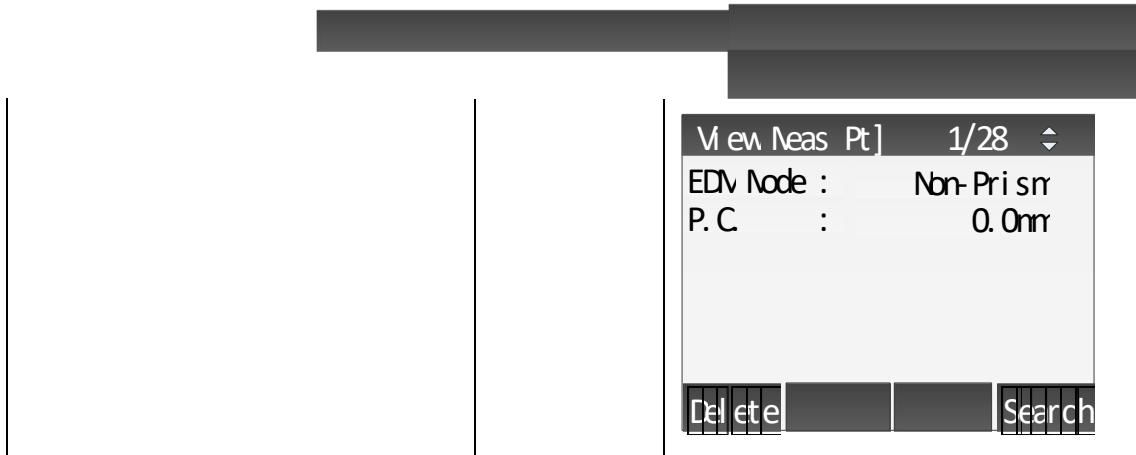

## 6. Stakeout

The Stakeout Application can calculate lofting elements base on lofting point's coordinate or manually input angle or horizontal distance. The application can continuously display differences, between current position and desired stake out position.



### Steps of Stakeout :

1. Set the job.
2. Set the station
3. Set the orientation
4. Extract coordinates from memory. The coordinates may be a measured point or a manually entered fix point.
5. Start staking out. There are three ways to choose: Polar Stakeout mode, Orthogonal to Station Stakeout mode, Cartesian Stakeout mode.

### 6.1 Set Stakeout Point

#### ● Extract coordinates from job

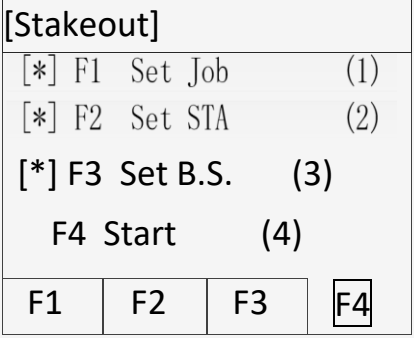
Steps	Key	Display
-------	-----	---------

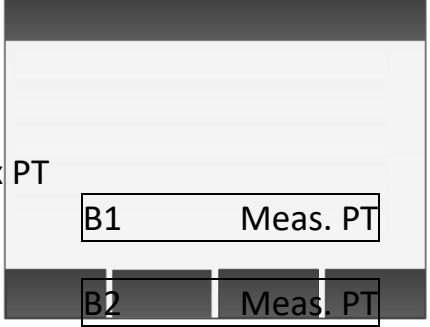
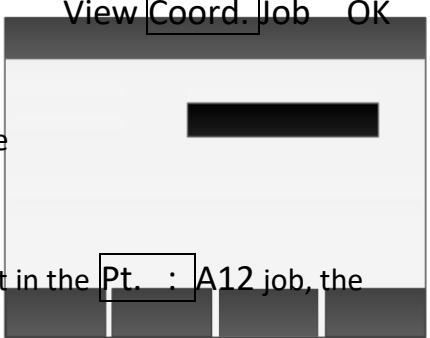
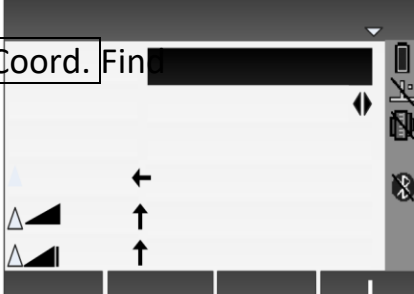
<p>O1 After finishing setting the job, setting the station and setting the orientation, press [F4] to start staking out in the Pre-Setting menu. ""1</p>	<p>[F4]</p>	
<p>O2 Input the name of stakeout point in the Search item. Press [ENT] to start Find Point function. (Or input wildcard "*"to start the wildcard search.)</p>	<p>stakeout point's name Hz +</p>	
<p>Input [Stakeout] 1/3 Search : * O3 A: [Find Pt.] 1/20 The program search the point name in the job and show the result dialog. The match points B3 [F4](OK) to B4 Meas. PT identify selected point and back to Stakeout screen. (If the input is wildcard "*", the program will show all the points of the current job.)""2 [Find Pt.] B: Job : DEFAULT If there is no match point in the Pt. : A12 job, the program prompts "Pt. not found!". And then go in Find</p>	<p>[ENT] ALL 5 Fix PT</p>	 <p>Meas. PT will be listed, press View Coord. Job OK</p>  <p>Select job or input coord.!</p>
<p>Point In Job screen. User can input a point or select a point</p>	<p>Job Zero Coord. Fin</p>	

---

---

from another job and then back to Stakeout screen.

[ S takeout] 1/3

Search : \*

Pt. : 5

O4 After finishing setting T□.HzH ::  
13°291'.55090" m T

stakeout point, start staking out. \_ : -0.108m

: -0.175m ALLDIST  
REC

""1: The settings of job, station and orientation have been elaborated in detail in the previous chapters, here is no longer repeat. Refer to chapters "Setting The Job、 Setting The Station、 Setting The Orientation".

""2: Unlike the other place's points list, the stakeout points are ordered by time. In

the stakeout points list, the newest point is at the back and the fix point is in the front of measured point. But in the other points list, the newest point is at the back and the measured point is in the front of fix point.

● **Manual input stakeout point**

Press key [Coord.] or [SO-PT] to manual input stakeout point coordinates and then continue staking out.

**[Coord.]:**

Press [Coord.] and then input a target point's coordinates. Saved this point into job and continue staking out.

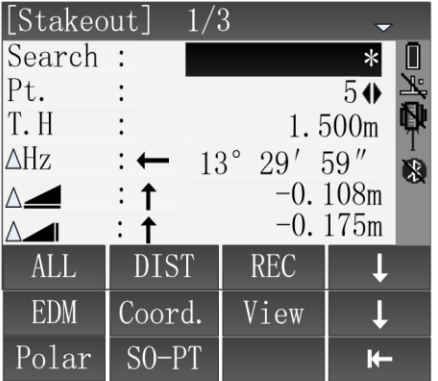
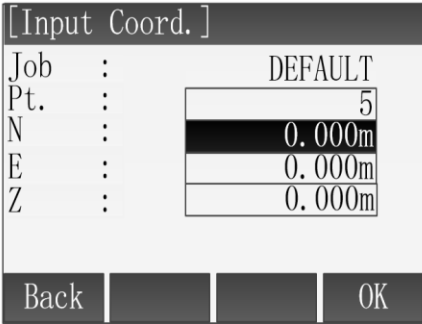
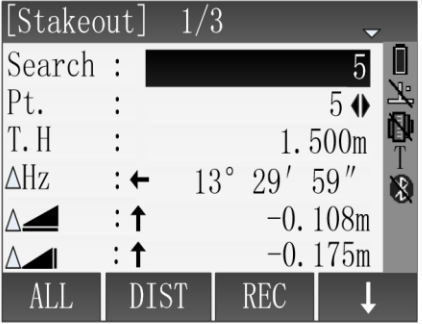
Steps	Key	Display
<p>① Press [F4] (↓) to view the second page of soft keys.</p>	<p>[F4]</p>	 <p>[Stakeout] 1/3            Search : [redacted] *            Pt. : 5            T. H : 1.500m            ΔHz : ← 13° 29' 59"            Δ : ↑ -0.108m            Δ : ↑ -0.175m            ALL DIST REC ↓            EDM Coord. View ↓            Polar SO-PT ←</p>
<p>② Press [F2](Coord.) to go to Input Coord. Screen. Input point name and coordinate of the stakeout point. After input one item, the cursor will move to next input item.</p>	<p>[F2] + Input point name and coordinates + [ENT]</p>	 <p>[Input Coord.]            Job : DEFAULT            Pt. : [redacted] 5            N : [redacted] 0.000m            E : [redacted] 0.000m            Z : [redacted] 0.000m            Back OK</p>
<p>③ After finishing inputs, press [F4](OK) to save the data. And then back to Stakeout screen. Start to stakeout the input point.</p>		 <p>[Stakeout] 1/3            Search : [redacted] 5            Pt. : 5            T. H : 1.500m            ΔHz : ← 13° 29' 59"            Δ : ↑ -0.108m            Δ : ↑ -0.175m            ALL DIST REC ↓</p>

**[SO-PT]:**

Press [SO-PT] to input a stakeout point without point name and being saved into job.

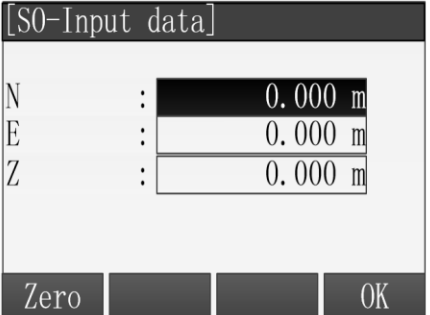
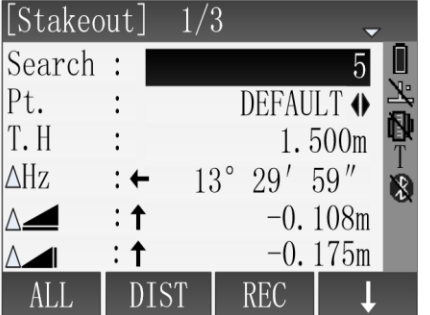
Steps	Key	Display
<p>① Press [F4] ( ↓ ) to view the third page of soft keys.</p>	<p>[F4]</p>	
<p>② Press [F2](SO-PT) to go to SO-Input data screen. Input the coordinates of stakeout point. After input one item, the cursor will move to next input item.</p>	<p>[F2] + Input point name and coordinates + [ENT]</p>	
<p>③ After finishing inputs, press [F4](OK) to save the data. And then back to Stakeout screen. Start to stakeout the input point. The program will name this point <b>DEFAULT</b> automatically. ※<sup>1</sup></p>		
<p>※<sup>1</sup>: [SO-PT]: The input point won't be saved into job.</p>		

## 6.2 Polar Stakeout Mode

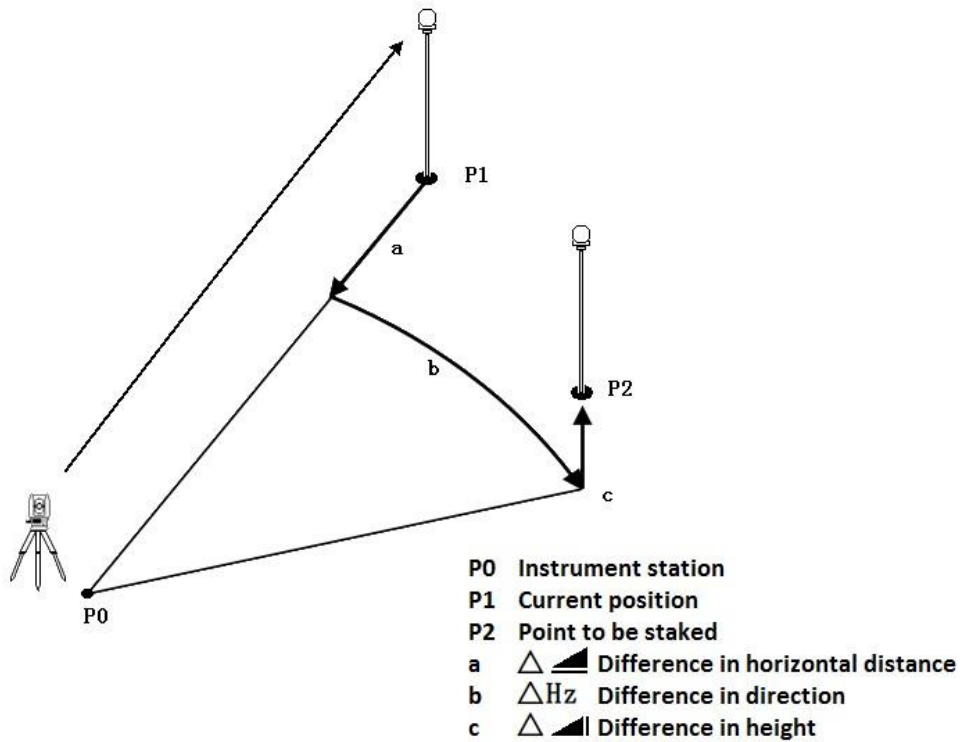

The meanings of the differences in the Polar Stakeout mode:

$\triangle$  Hz Difference in direction: If the measured point is located in the right side of stakeout point, the value is positive.

$\triangle$   $\blacktriangleleft$  Difference in horizontal distance: If the measured point is farther than stakeout point, the value is positive.

$\triangle$   $\blacktriangleleft$  Difference in height: If the measured point is higher than stakeout point, the value is positive.

Steps	Key	Display
-------	-----	---------

<p>O1 Set all the points that are readied to stake out. Select one stakeout point through search the point name in the job.</p>		 <p>[ S takeout] 1/3  Search : *  Pt. :5  T.H : 1.500m T  Hz : --- -----  △ : --- ----- : --- -  △ : --- -----  -----  ALL DIST REC</p>
---	--	---

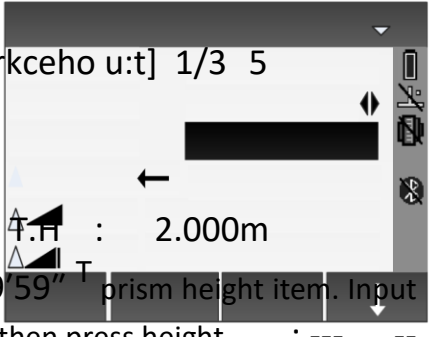
<p>O2 Press [PAGE] to go to page 1/3(Default page). Press direction key and move the cursor to input the Input prism height and then press height</p>	<p>[PAGE]  [S Se taarkceho u:t] 1/3 5  Pt. : 5  Hz : 13°29'59" T</p>	 <p>[S Se taarkceho u:t] 1/3 5  Pt. : 5  T.H : 2.000m  △ : --- -----  △ : --- -----  -----</p>
---	--	---

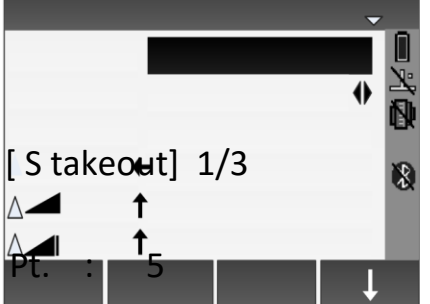
<p>O3 Aim at the prism. Press [ENT] to confirm. + ALL DIST REC</p>	<p>[ENT]  Search : 5</p>	 <p>[ S takeout] 1/3  △ : --- -----  △ : --- -----  Pt. : 5  -----</p>
--	------------------------------	--

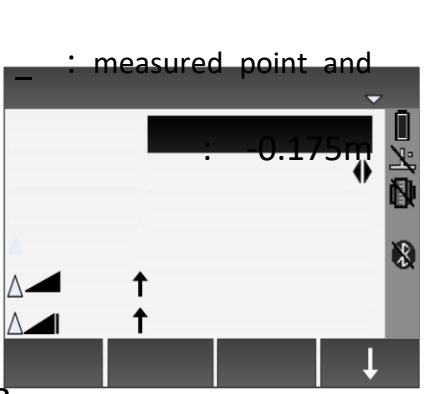
<p>[F2](DIST) to start measuring and differences between stakeout -0.108m point. ALL DIST REC</p> <p>O4 Turn the instrument telescope to make the ΔHz equal 0° 00' 00" and</p>	<p>[F2] T Hz  :: 13°291'.55090" m T calculate the  : measured point and  : 0.175m</p> <p>[ S takeout] 1/3  Search : 5</p>	 <p>[ S takeout] 1/3  △ : --- -----  △ : --- -----  Pt. : 5  -----</p>
--	---	--

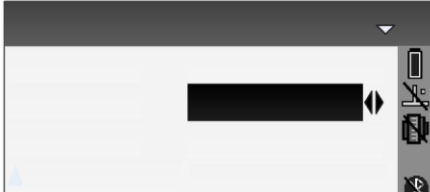
<p>command the staff to move the</p>	<p>Pt. : 5</p>	
--------------------------------------	----------------	--



---

T.H : 1.500m T

prism at the same time. Hz : \* 0°00'00"

Arrows Meaning:  $\_$  : -0.108m

←: Look forward from station : -0.175m and move the prism to the left. ALL DIST REC

→: Look forward from station and move the prism to the right.

○5 While the  $\Delta$ Hz equals 0°

[ S takeout] 1/3





00'00", press [F2](DIST) to Search : 5

start measuring and calculate the Pt. : 5

T.H : 2.000m T

differences between measured [F2] Hz : \* 0°00'00" point and stakeout point.

: -0.324m The arrow's direction is the : -0.309m direction of the prism need to ALL DIST REC move.

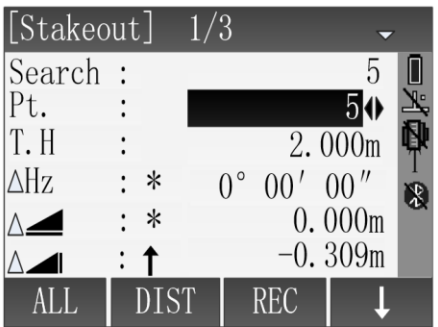
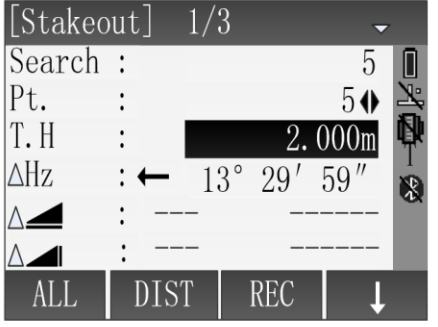
<p>⑥ Move the prism according to the direction of the arrow to make the value of <math>\Delta</math>  equal 0m.</p> <p>Arrows Meaning:</p> <p>↓ : Move the prism close to the station.</p> <p>↑ : Move the prism far away the station.</p> <p>In the process of staking out, if using the Repeat Measurement or Tracking Measurement, the calculation of the differences between measured point and stakeout point can be displayed in real time and convenient.</p>		
<p>⑦ It means the current prism position is effective stakeout point while both the <math>\Delta</math>Hz and <math>\Delta</math>  are 0.</p> <p><math>\Delta</math>  Display as dig or fill data.</p> <p>↓ : The value expresses the depth of needed to dig.</p> <p>↑ : The value expresses the height of needed to fill.</p>		
<p>⑧ Now it finishes staking out a point. Repeat the previous steps to stake out next point.</p>		

### 6.3 Orthogonal to Station Stakeout Mode

Use longitudinal difference and perpendicular difference to indicate the position differences of stakeout point and current prism position.

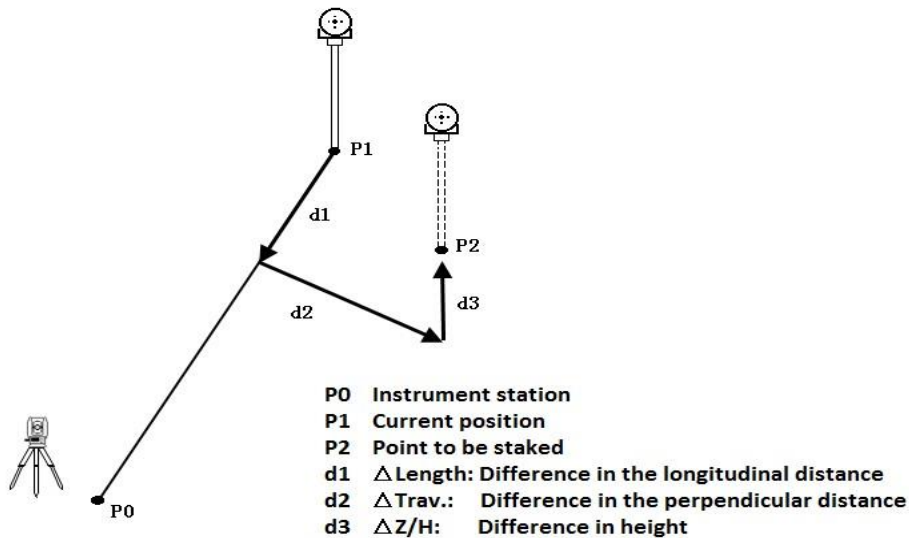

The meanings of the differences in the Orthogonal to Station Stakeout Mode:

$\Delta$ Length Difference in longitudinal distance: If the measured point is farther than stakeout point, the value is positive.

$\Delta$ Trav. Difference in perpendicular distance: If the measured point is located in the right side of stakeout point, the value is positive.



Steps	Key	Display
O1 Press [PAGE] to show [ S takeout] 2/3 Orthogonal to Station Stakeout Pt. : 6 Mode in page 2/3. Set the [PAGE] T.H : 1.500m $\uparrow$ stakeout point. The stakeout Length: --- ----- point can be found in the job		
through inputting point name in ALL DIST REC the search item. [ S takeout] 2/3 O2 Press direction key and move + Pt. : 6	[down arrow] +	

---

T.H : 1.800m  
the cursor to input prism height Input prism Length: --- ----- T item. Input the  
prism height and height Trav. : --- -----then press [ENT] to confirm. + Z/H :  
--- -----

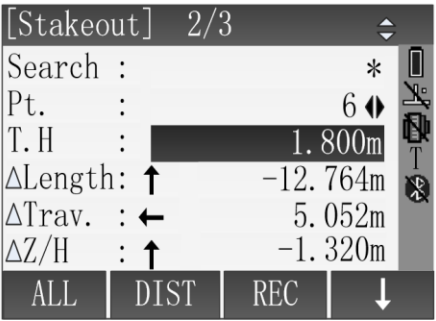
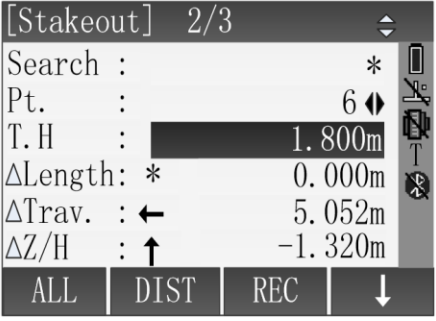
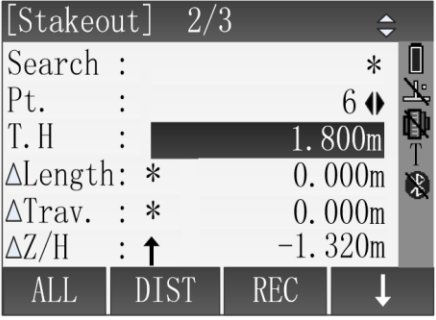
[ENT] ALL DIST REC

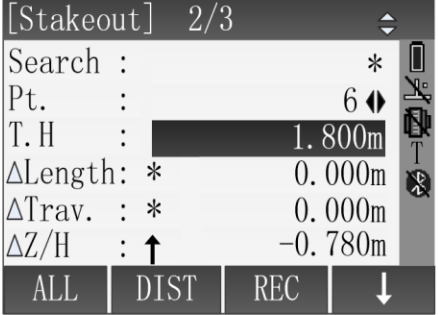
<p>③ Aim at the prism. Press [F2](DIST) to start measuring and calculate the differences between measured point and stakeout point.</p> <p>The arrow's direction is the direction of the prism need to move.</p>	<p>[F2]</p>	
<p>④ Move the prism according to the direction of the arrow to make the value of <math>\Delta</math> Length equal 0m.</p> <p>Arrows Meaning:</p> <p>↓ : Move the prism close to the station.</p> <p>↑ : Move the prism far away the station.</p> <p>In the process of staking out, if using the Repeat Measurement or Tracking Measurement, the calculation of the differences between measured point and stakeout point can be displayed in real time and convenient.</p>		
<p>⑤ Turn the instrument telescope to find the direction where makes the <math>\Delta</math>Trav. equal 0m and command the staff to move the prism at the same time.</p> <p>Arrows Meaning:</p> <p>← : Look forward from station and move the prism to the left.</p> <p>→ : Look forward from station and move the prism to the right.</p>		

<p>⑥ It means the current prism position is effective stakeout point while both the <math>\Delta</math> Length and <math>\Delta</math> Trav. are 0.</p> <p><math>\Delta</math>Z/H: Display as dig or fill data.</p> <p>↓ : The value expresses the depth of needed to dig.</p> <p>↑ : The value expresses the height of needed to fill.</p>		 <p>[Stakeout] 2/3</p> <p>Search : *</p> <p>Pt. : 6</p> <p>T. H : 1.800m</p> <p><math>\Delta</math>Length: * 0.000m</p> <p><math>\Delta</math>Trav. : * 0.000m</p> <p><math>\Delta</math>Z/H : ↑ -0.780m</p> <p>ALL   DIST   REC   ↓</p>
<p>⑧ Now it finishes staking out a point. Repeat the previous steps to stake out next point.</p>		 <p>[Stakeout] 2/3</p> <p>Search : *</p> <p>Pt. : 6</p> <p>T. H : 1.800m</p> <p><math>\Delta</math>Length: ---</p> <p><math>\Delta</math>Trav. : ---</p> <p><math>\Delta</math>Z/H : ---</p> <p>ALL   DIST   REC   ↓</p>

## 6.4 Cartesian Stakeout Mode

Stake out point based on the Cartesian coordinate system. The deviation values are the coordinate differences.

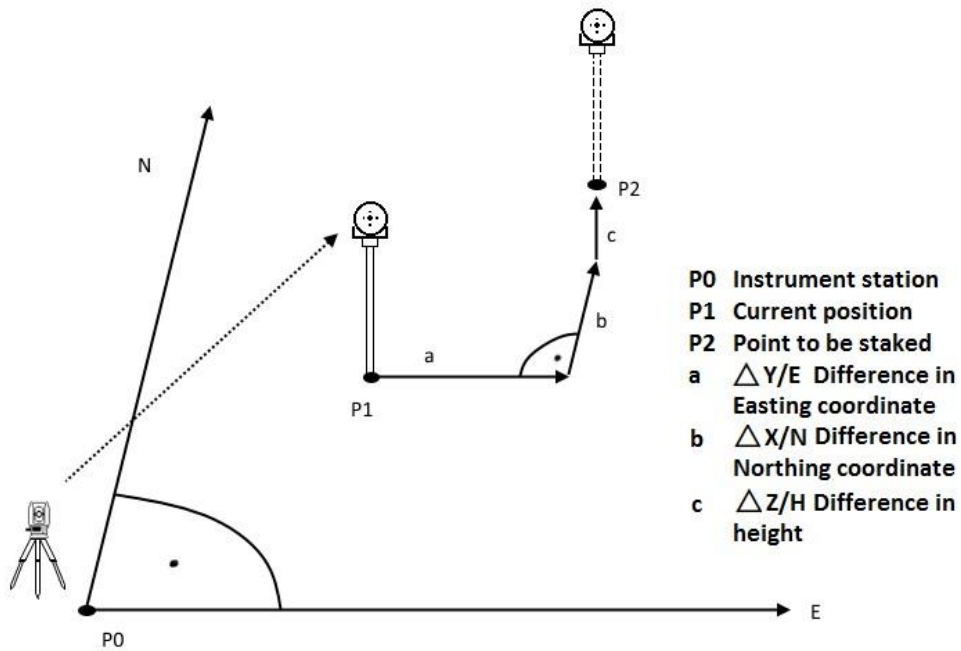

The meanings of the differences in the Cartesian Stakeout Mode:

$\Delta Y/E$  The difference in East coordinate between measured point and stakeout point.

$\Delta X/N$  The difference in North coordinate between measured point and stakeout point.



Steps	Key	Display
<p>○1 Press [PAGE] to show Cartesian Stakeout Mode in page 3/3. Set the stakeout point. The stakeout point can be found in the job through inputting point name in the search item.</p>	[PAGE]	

---

--	--	--

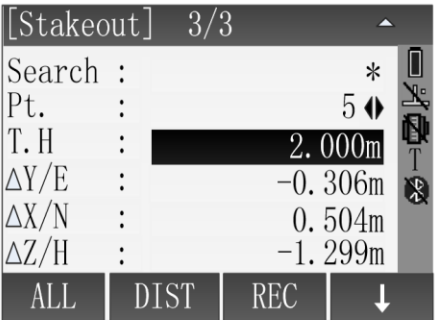
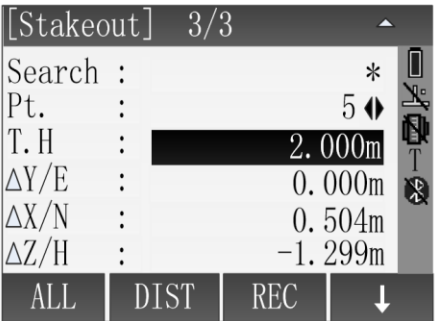
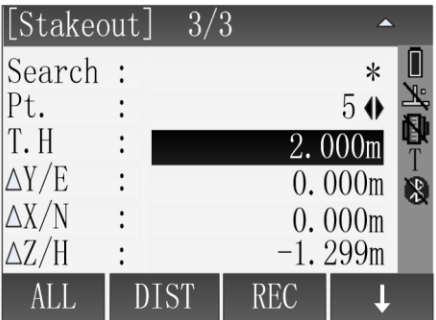

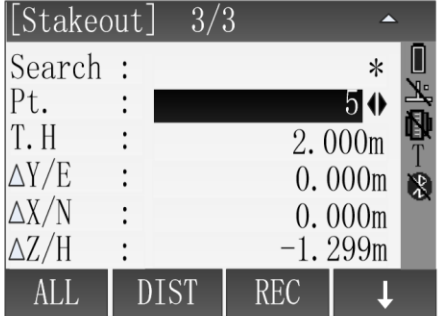
<p>② Press direction key and move the cursor to input prism height item. Input the prism height and then press [ENT] to confirm.</p>	<p>↓ + Input prism height + [ENT]</p>	 <p>[Stakeout] 3/3 Search : * Pt. : 5 T.H : 2.000m ΔY/E : ----- ΔX/N : ----- ΔZ/H : ----- ALL   DIST   REC   ↓</p>
<p>③ Aim at the prism. Press [F2](DIST) to start measuring and calculate the differences between measured point and stakeout point.</p>	<p>[F2]</p>	 <p>[Stakeout] 3/3 Search : * Pt. : 5 T.H : 2.000m ΔY/E : -0.306m ΔX/N : 0.504m ΔZ/H : -1.299m ALL   DIST   REC   ↓</p>
<p>④ Move the prism along the East direction to make the value of ΔY/E equal 0m. ΔY/E is positive: The stakeout point is in the right side of measured point. Move the prism to right. ΔY/E is negative: The stakeout point is in the left side of measured point. Move the prism to left.</p>		 <p>[Stakeout] 3/3 Search : * Pt. : 5 T.H : 2.000m ΔY/E : 0.000m ΔX/N : 0.504m ΔZ/H : -1.299m ALL   DIST   REC   ↓</p>
<p>⑤ Move the prism along the North direction to make the value of ΔX/N equal 0m. ΔX/N is positive: The stakeout point is farther than the measured point. Move the prism far away the station. ΔX/N is negative: It needs to move the prism close to the station. In the process of staking out, if</p>		 <p>[Stakeout] 3/3 Search : * Pt. : 5 T.H : 2.000m ΔY/E : 0.000m ΔX/N : 0.000m ΔZ/H : -1.299m ALL   DIST   REC   ↓</p>

<p>using the Repeat Measurement or Tracking Measurement, the calculation of the differences between measured point and stakeout point can be displayed in real time and convenient.</p>		
<p>⑥ It means the current prism position is effective stakeout point while both the <math>\Delta Y/E</math> and <math>\Delta X/N</math> are 0.  <math>\Delta Z/H</math>: Display as dig or fill data.  <math>\Delta Z/H</math> is positive: The value expresses the depth of needed to dig.  <math>\Delta Z/H</math> is negative: The value expresses the height of needed to fill.</p>		
<p>⑧ Now it finishes staking out a point. Repeat the previous steps to stake out next point.</p>		

**6.5 Polar**

Press [Polar], then input the polar stakeout elements: Azimuth and Horizontal

distance. Start to stake out after finishing inputs of Azimuth and Horizontal distance.

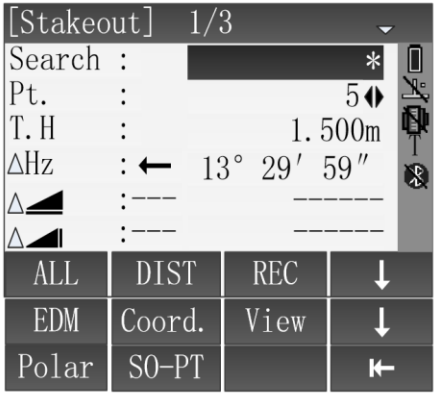
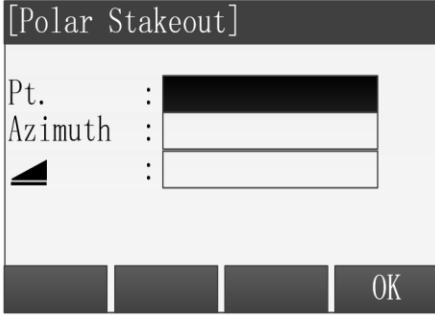
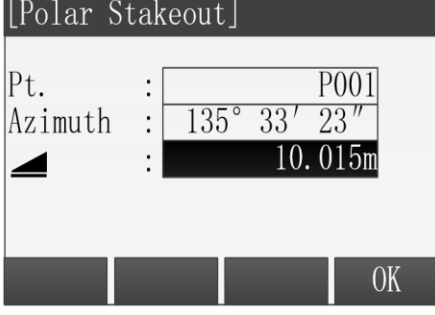
Steps	Key	Display
<p>① Press [F4](↓) twice to view the second page soft keys.</p>	<p>[F4]</p>	
<p>② Press [F1](Polar) to show the dialog as shown in figure.</p>	<p>[F1]</p>	
<p>③ Input the stakeout point's name, azimuth and horizontal distance. Press [ENT] to confirm every input and move the cursor to next input item. Press [F4](OK) to go to Polar Stakeout screen after finishing all inputs. ※<sup>1</sup></p>	<p>Input point name, azimuth and horizontal distance + [ENT] + [F4]</p>	

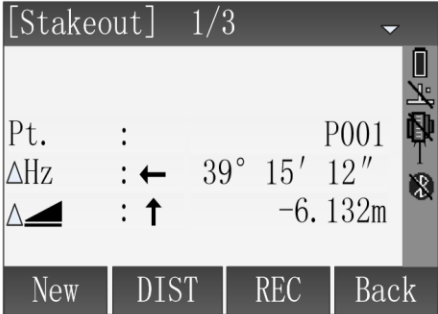
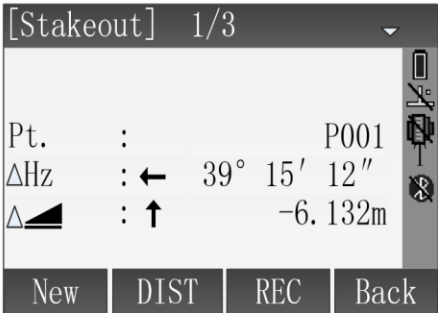
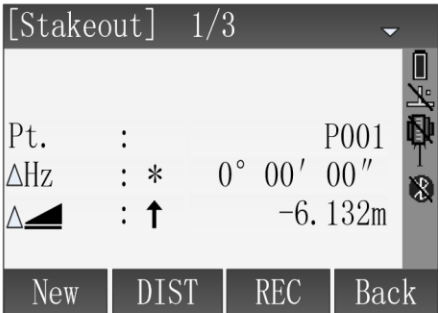
<p>④ Aim at the prism. Press [F2](DIST) to start measuring and calculate the differences between measured point and stakeout point.</p>	<p>[F2]</p>	
<p>⑤ Turn the instrument telescope to make the <math>\Delta</math> Hz equal <math>0^{\circ}00'00''</math> and command the staff to move the prism at the same time.</p> <p><math>\Delta</math> Hz is positive: The stakeout point is in the left side of measured point. Move the prism to left.</p> <p><math>\Delta</math> Hz is negative: The stakeout point is in the right side of measured point. Move the prism to right.</p>		
<p>⑥ Set and aim at the prism in the direction of <math>\Delta</math> Hz = <math>0^{\circ}00'00''</math>. Press [F2](DIST) to start measuring and calculate the differences between measured point and stakeout point.</p> <p><math>\Delta</math> is positive: The stakeout point is closer to the station. Move the prism close to the station.</p> <p><math>\Delta</math> is negative: The stakeout point is farther to the station. Move the prism far away the station.</p>	<p>[F2]</p>	

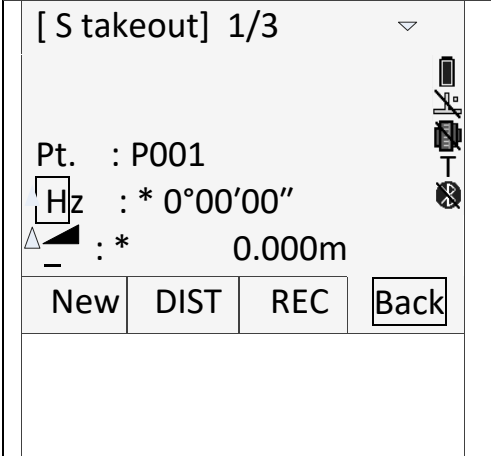
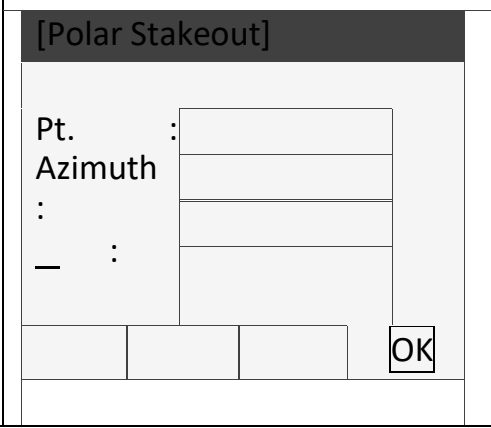
<p>○7 Move the prism along the arrow direction to make the value of  equal 0m.</p> <p>In the process of staking out, if using the Repeat Measurement or Tracking Measurement, the calculation of the differences between measurement point and stakeout point can be displayed in real time and convenient.</p>		
<p>○8 Now it finishes staking out a point. Repeat the previous steps○2 ~○7 to stake out next point.</p>		
<p>'''1: The inputs of polar coordinate data won't be saved to job.</p>		

## 7. Resection

Resection measurement is an application used to determine the coordinate of the instrument station by measuring multiple known points. A minimum of 2 and a maximum of 5 known points can be used to determine the station. It should be used at least 2 known points by distance measurement or at least 3 known points by angle

measurement.

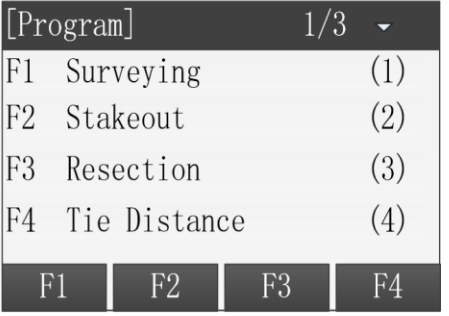
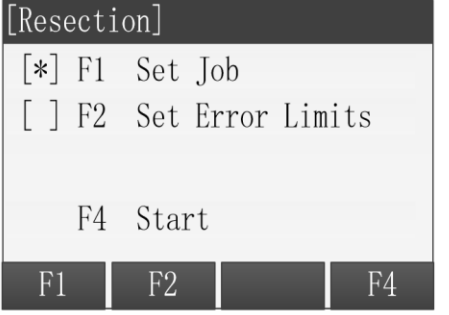
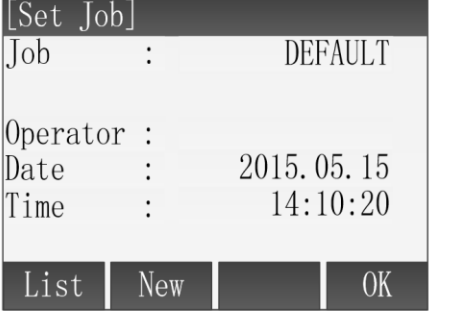
Steps	Key	Display
<p>① Select “Program” from the [Main Menu] window, press [F3] or number key [3] to enter the Resection application.</p>	<p>[F3]</p>	
<p>② Press [F1] in the [Resection] window to set the job.</p>	<p>[F1]</p>	
<p>③ In [Set Job] window, press [F1] (List) to select a job in memory or press [F2] (New) to new a job. Then press [F4] (OK) to next step.</p>	<p>[F4]</p>	

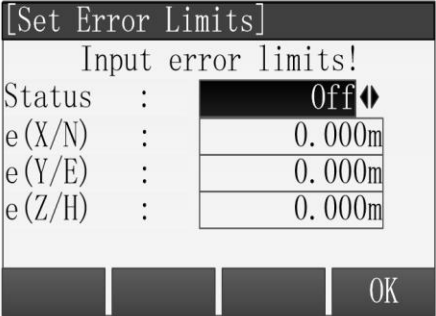
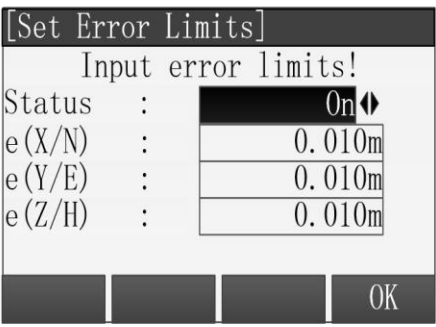
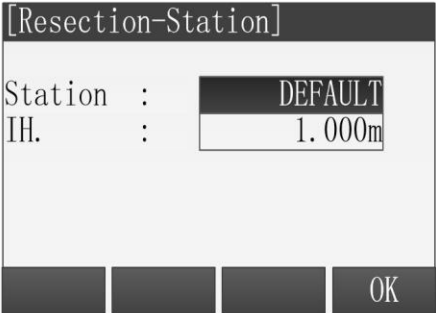
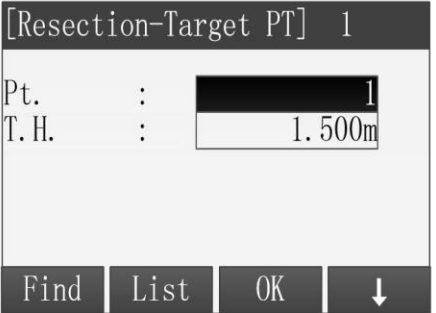
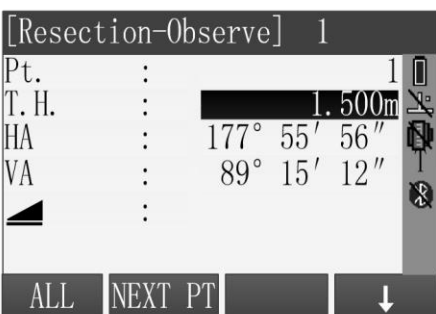
<p>④ The window back to the [Resection] window, and press [F2] to set error limits.</p>	<p>[F2]</p>	
<p>⑤ Press [◀] \ [▶] to turn on the error limits status and use the key [▲] \ [▼] to move the focus down to input the every error limit. Then press [F4] (OK) to set and back to the [Resection] window.</p>	<p>Input error limits + [F4]</p>	
<p>⑥ Press [F4] in [Resection] window to start resection measurement. It should be input the station name and the instrument high. Then press [F4] (OK) go to next step.</p>	<p>[F4] Input name and IH. + [ENT] [F4]</p>	
<p>⑦ Set the first known point and input prism high. ※<sup>1</sup>The title bar will display the number of known points in the current setting.</p>		
<p>⑧ Turn the instrument telescope aimed at first point and press [F1] to finish current measurement.  Angle measurement: press [F2] (REC) to record an angle.</p>	<p>[F1]</p>	

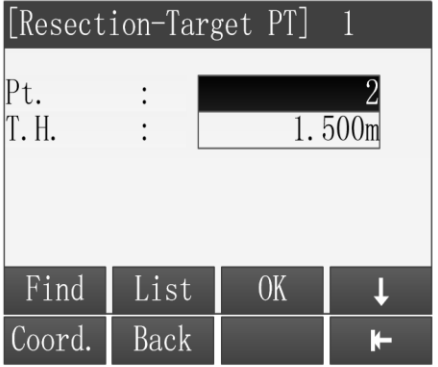
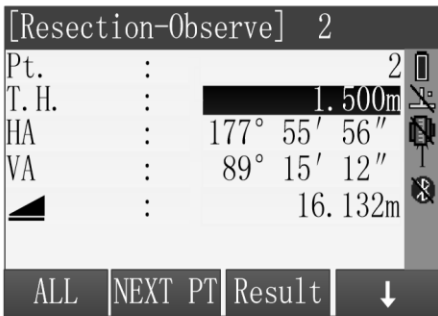
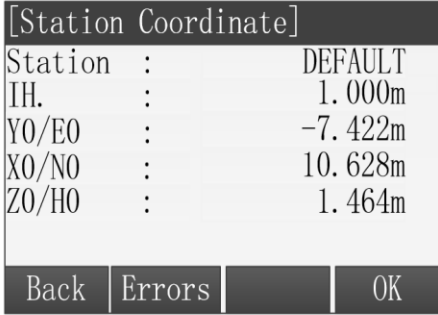
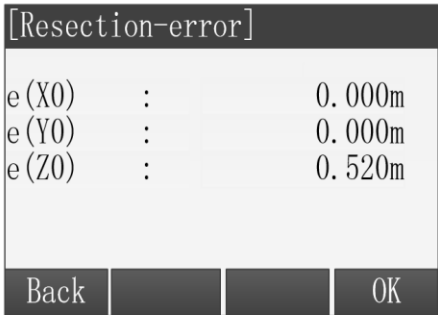
<p>Distance measurement: [F1] (ALL) or [F1] + [F2] (DIST + REC).</p>		
<p>⑨ When finish a known point measurement, press [F2] (NEXT PT) to start next known point measurement. Repeat steps ⑦ and ⑧.</p>	<p>[F2]</p>	
<p>⑩ If the measured known points are enough, [Result] will display on the screen, then press [F3] (Result) to enter the [Station Coordinate] to view station result.</p> <p>Press [F1] (Back) back to a new known point measurement.</p> <p>Press [F2] (errors) to display standard deviation.</p> <p>Press [F4] (OK) to set the station coordinate and instrument height.</p>		 <p>Press [F3] (Result) to enter the [Station Coordinate] to view result.</p>  <p>Display standard deviation:</p> 
<p>※<sup>1</sup>: The known points can be called from the memory through the [Find], [List] or manually entered used [Coord.].</p>		



## 8. Tie Distance

Tie Distance is an application used to compute slope distance, horizontal distance, height difference and azimuth of two target points which are either measured, selected from the memory, or input using the keypad.

The user can choose between two different methods:

- Polygonal: P1-P2, P2-P3, P3-P4
- Radial: P1-P2, P1-P3, P1-P4

Start Tie Distance application through "Main Menu" → "Program" → "Tie Distance".

### 8.1 Polygonal

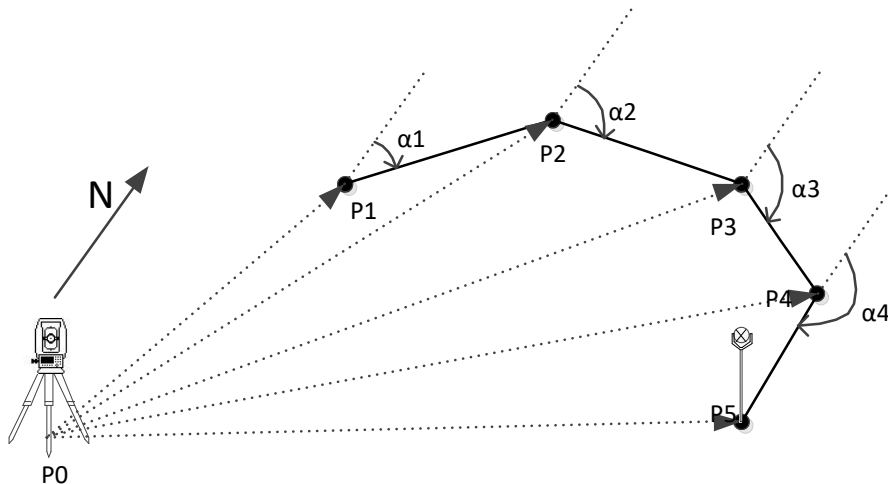

While Polygonal tie distance measuring continuous points, the new tie distance's first point will use the previous one tie distance's second point (P1-P2、 P2-P3、 P3-P4,,,,).

Steps	Key	Display
<p>O1 Press [F4] in the Program</p> <p>Menu to go to Tie Distance application.</p>	[F4]	<div style="border: 1px solid black; padding: 5px;"> <p>[Program] 1/3 ▾</p> <p>F1 Surveying (1)</p> <p>F2 Stakeout (2)</p> <p>F3 Resection (3)</p> <p>F4 Tie Distance (4)</p> <p>F1   F2   F3   <span style="border: 1px solid black; padding: 2px;">F4</span></p> </div>

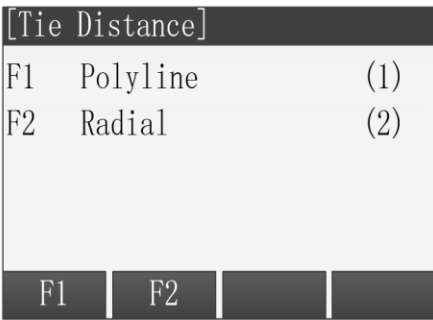
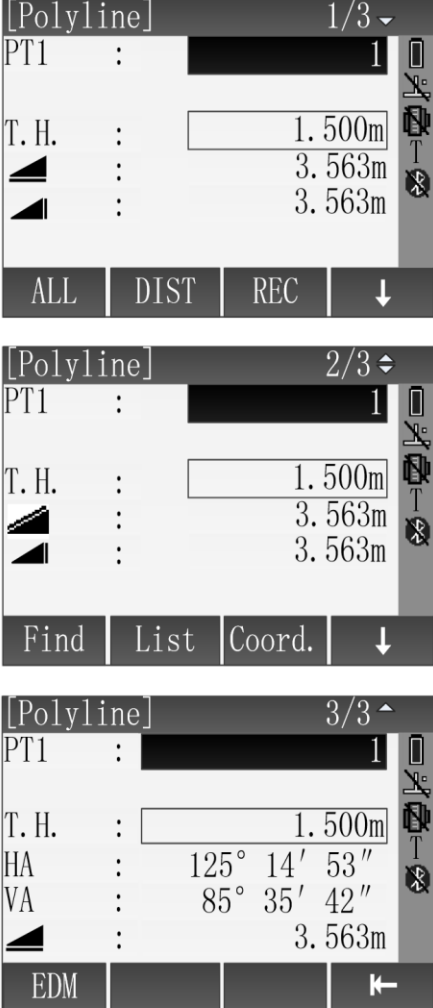
<p>② After finishing setting job, station and orientation, press [F4] in the Pre-Setting menu to go to Select Tie Distance Mode screen.</p>	<p>[F4]</p>	
<p>③ Press [F1] to select the Polygonal tie distance.</p>	<p>[F1]</p>	
<p>④ Start to measure the first target point. Aim at the first target point and press [F1](ALL) or [F2](DIST) + [F3](REC) to finishing measurement. ※<sup>1</sup></p>	<p>PAGE1 Press [F1] or [F2] + [F3]</p>	

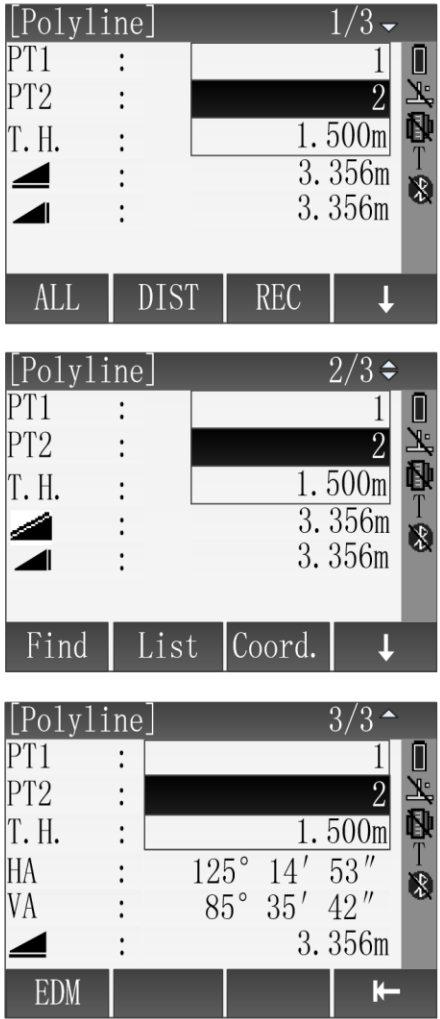
<p>⑤ Start to measure the second target point. Aim at the second target point and press [F1](ALL) or [F2](DIST) + [F3](REC) to finishing measurement. ※<sup>1</sup></p>	<p>PAGE1 Press [F1] or [F2] + [F3]</p>	 <p>[Polyline] 1/3</p> <table border="1"> <tr><td>PT1</td><td>:</td><td>1</td></tr> <tr><td>PT2</td><td>:</td><td>2</td></tr> <tr><td>T. H.</td><td>:</td><td>1.500m</td></tr> <tr><td>▲</td><td>:</td><td>3.356m</td></tr> <tr><td>▲</td><td>:</td><td>3.356m</td></tr> </table> <p>ALL   DIST   REC   ↓</p> <p>[Polyline] 2/3</p> <table border="1"> <tr><td>PT1</td><td>:</td><td>1</td></tr> <tr><td>PT2</td><td>:</td><td>2</td></tr> <tr><td>T. H.</td><td>:</td><td>1.500m</td></tr> <tr><td>▲</td><td>:</td><td>3.356m</td></tr> <tr><td>▲</td><td>:</td><td>3.356m</td></tr> </table> <p>Find   List   Coord.   ↓</p> <p>[Polyline] 3/3</p> <table border="1"> <tr><td>PT1</td><td>:</td><td>1</td></tr> <tr><td>PT2</td><td>:</td><td>2</td></tr> <tr><td>T. H.</td><td>:</td><td>1.500m</td></tr> <tr><td>HA</td><td>:</td><td>125° 14' 53"</td></tr> <tr><td>VA</td><td>:</td><td>85° 35' 42"</td></tr> <tr><td>▲</td><td>:</td><td>3.356m</td></tr> </table> <p>EDM   ←</p>	PT1	:	1	PT2	:	2	T. H.	:	1.500m	▲	:	3.356m	▲	:	3.356m	PT1	:	1	PT2	:	2	T. H.	:	1.500m	▲	:	3.356m	▲	:	3.356m	PT1	:	1	PT2	:	2	T. H.	:	1.500m	HA	:	125° 14' 53"	VA	:	85° 35' 42"	▲	:	3.356m
PT1	:	1																																																
PT2	:	2																																																
T. H.	:	1.500m																																																
▲	:	3.356m																																																
▲	:	3.356m																																																
PT1	:	1																																																
PT2	:	2																																																
T. H.	:	1.500m																																																
▲	:	3.356m																																																
▲	:	3.356m																																																
PT1	:	1																																																
PT2	:	2																																																
T. H.	:	1.500m																																																
HA	:	125° 14' 53"																																																
VA	:	85° 35' 42"																																																
▲	:	3.356m																																																
<p>⑥ Show the result of polygonal tie distance. [NewPt1]: Start a new polygonal tie distance. [NewPt2]: This polygonal tie distance's second point will be the new polygonal tie distance's first point and then go to ⑤ to measure the new second target point. [Radial]Radial: Go to Radial tie distance.</p>		<table border="1"> <tr><td>PT1</td><td>:</td><td>1</td></tr> <tr><td>PT2</td><td>:</td><td>2</td></tr> <tr><td>Slope</td><td>:</td><td>2.9%</td></tr> <tr><td>▲</td><td>:</td><td>+1.232m</td></tr> <tr><td>▲</td><td>:</td><td>-0.562m</td></tr> <tr><td>▲</td><td>:</td><td>+0.362</td></tr> <tr><td>Azimuth</td><td>:</td><td>12° 27' 13"</td></tr> </table> <p>NewPt1   NewPt2   Radial</p>	PT1	:	1	PT2	:	2	Slope	:	2.9%	▲	:	+1.232m	▲	:	-0.562m	▲	:	+0.362	Azimuth	:	12° 27' 13"																											
PT1	:	1																																																
PT2	:	2																																																
Slope	:	2.9%																																																
▲	:	+1.232m																																																
▲	:	-0.562m																																																
▲	:	+0.362																																																
Azimuth	:	12° 27' 13"																																																
<p>※<sup>1</sup>: The target points can be measured, selected from the memory, or input using the keypad.</p>																																																		

## 8.2 Radial

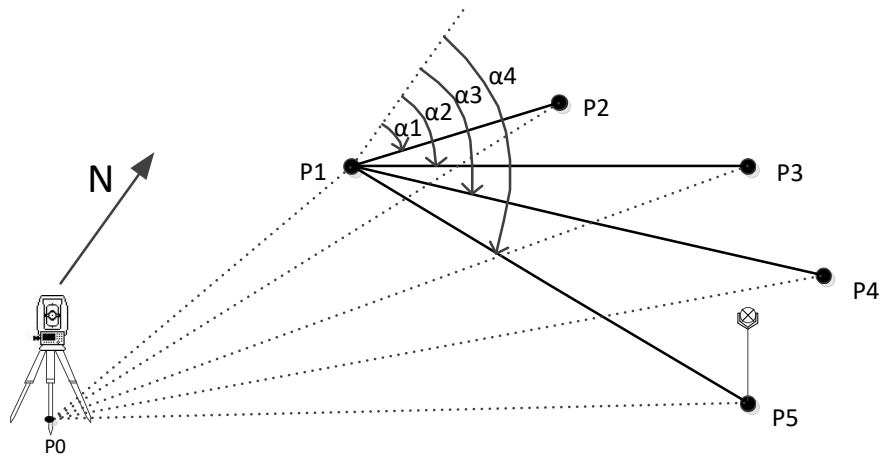

While Radial tie distance measuring continuous points, the new tie distance's first point continues using the previous tie distance's first point(P1-P2、 P1-P3、 P1-P4.....).

Steps	Key	Display												
① Press [F4] in the Program Menu to go to Tie Distance application.	[F4]	<div style="border: 1px solid black; padding: 5px;"> <div style="background-color: #333; color: white; padding: 2px;">[Program] 1/3 ▾</div> <table style="width: 100%; border-collapse: collapse;"> <tr> <td style="width: 15%;">F1</td> <td style="width: 60%;">Surveying</td> <td style="width: 25%; text-align: right;">(1)</td> </tr> <tr> <td>F2</td> <td>Stakeout</td> <td style="text-align: right;">(2)</td> </tr> <tr> <td>F3</td> <td>Resection</td> <td style="text-align: right;">(3)</td> </tr> <tr> <td>F4</td> <td>Tie Distance</td> <td style="text-align: right;">(4)</td> </tr> </table> <div style="display: flex; justify-content: space-around; margin-top: 5px;"> <span style="border: 1px solid black; padding: 2px 5px;">F1</span> <span style="border: 1px solid black; padding: 2px 5px;">F2</span> <span style="border: 1px solid black; padding: 2px 5px;">F3</span> <span style="border: 1px solid black; padding: 2px 5px;">F4</span> </div> </div>	F1	Surveying	(1)	F2	Stakeout	(2)	F3	Resection	(3)	F4	Tie Distance	(4)
F1	Surveying	(1)												
F2	Stakeout	(2)												
F3	Resection	(3)												
F4	Tie Distance	(4)												
② After finishing setting job, station and orientation, press [F4] in the Pre-Setting menu to go to Select Tie Distance Mode screen.	[F4]	<div style="border: 1px solid black; padding: 5px;"> <div style="background-color: #333; color: white; padding: 2px;">[Tie Distance]</div> <table style="width: 100%; border-collapse: collapse;"> <tr> <td style="width: 15%;">[*] F1</td> <td style="width: 60%;">Set Job</td> <td style="width: 25%; text-align: right;">(1)</td> </tr> <tr> <td>[*] F2</td> <td>Set STA</td> <td style="text-align: right;">(2)</td> </tr> <tr> <td>[*] F3</td> <td>Set B.S.</td> <td style="text-align: right;">(3)</td> </tr> <tr> <td>F4</td> <td>Start</td> <td style="text-align: right;">(4)</td> </tr> </table> <div style="display: flex; justify-content: space-around; margin-top: 5px;"> <span style="border: 1px solid black; padding: 2px 5px;">F1</span> <span style="border: 1px solid black; padding: 2px 5px;">F2</span> <span style="border: 1px solid black; padding: 2px 5px;">F3</span> <span style="border: 1px solid black; padding: 2px 5px;">F4</span> </div> </div>	[*] F1	Set Job	(1)	[*] F2	Set STA	(2)	[*] F3	Set B.S.	(3)	F4	Start	(4)
[*] F1	Set Job	(1)												
[*] F2	Set STA	(2)												
[*] F3	Set B.S.	(3)												
F4	Start	(4)												

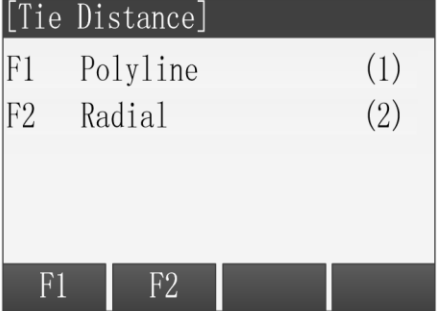
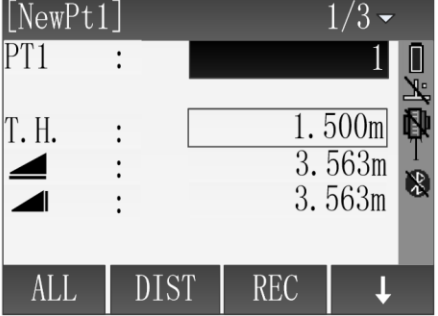
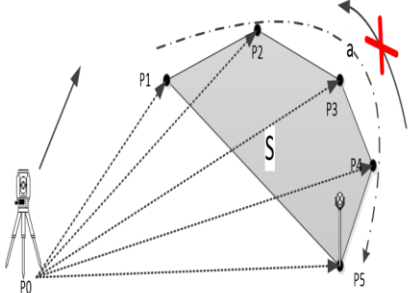
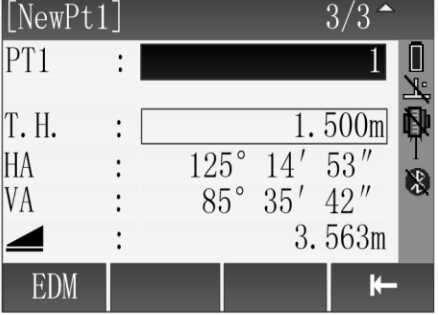
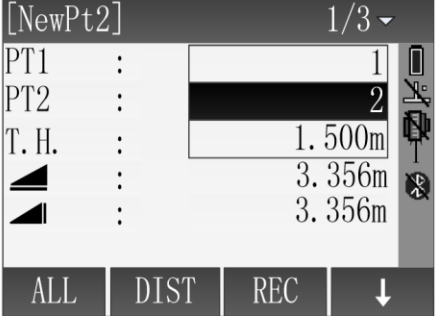
<p>③ Press [F2] to select the Polygonal tie distance.</p>	<p>[F2]</p>	
<p>④ Start to measure the first target point. Aim at the first target point and press [F1](ALL) or [F2](DIST) + [F3](REC) to finishing measurement. ※<sup>1</sup></p>	<p>PAGE1 Press [F1] or [F2] + [F3]</p>	  
<p>⑤ Start to measure the first target point. Aim at the first target point and press [F1](ALL) or [F2](DIST) + [F3](REC) to finishing measurement. ※<sup>1</sup></p>	<p>PAGE1 Press [F1] or [F2] + [F3]</p>	

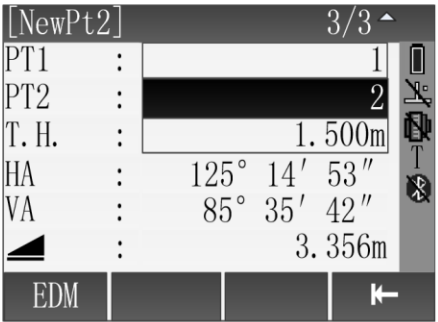
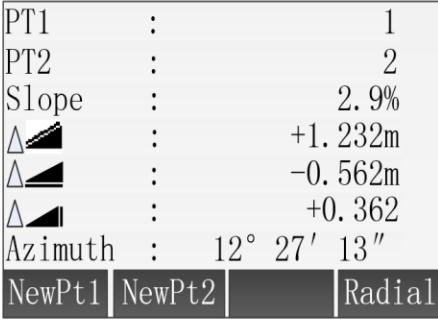
		 
<p>⑥ Show the result of Radial tie distance.</p> <p>[NewPt1]: Start a new Radial tie distance.</p> <p>[NewPt2]: This Radial tie distance's first point continues to be the new polygonal tie distance's first point and then go to ⑤ to measure the new second target point.</p> <p>[Polygonal]Radial: Go to Polygonal tie distance.</p>		
<p>※<sup>1</sup>: The target points can be measured, selected from the memory, or input using the keypad.</p>		

## 9. Area & Volume

Area is an application used to calculate the polygon areas to a maximum of 20 points which connected by straights. The target points coordinate can be measured, selected from memory or entered via keypad in same direction. And the following

three methods can be alternately performed. The calculate area is projected onto the horizontal plane (2D).

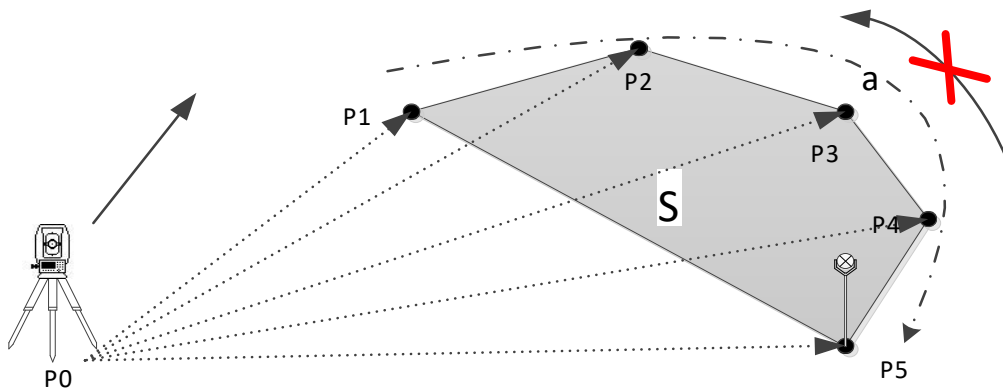

Figure 9.1 Area Diagram

P0 Instrument Point

P1 Start Target Point P1~P5 Target Point a Perimeter, polygonal length from start point to the current measure

point.

S Calculated area always closed to the start point P1, projected onto the horizontal plane.

Select “Program” from the [Main Menu] window, then press [PAGE] switch to second program list and press [F1] or number key [5] to enter the Area application.

Steps	Key	Display																			
<p>○1 Select “Program” from the [Main Menu] window, then press [PAGE] switch to second program list and press [F1] or number key [5] to enter the Area/volume app.</p>	<p>[PAGE] + [F1] or [5]</p>	<table border="1"> <tr> <td>[Program]</td> <td>2/3</td> <td>⇅</td> </tr> <tr> <td>F1 Area/volume</td> <td>(5)</td> <td>F2</td> </tr> <tr> <td>Remote Height</td> <td>(6)</td> <td>F3</td> </tr> <tr> <td>COGO</td> <td>(7)</td> <td></td> </tr> <tr> <td>F4 Road</td> <td>(8)</td> <td></td> </tr> <tr> <td>F1</td> <td>F2</td> <td>F3</td> <td>F4</td> </tr> </table>	[Program]	2/3	⇅	F1 Area/volume	(5)	F2	Remote Height	(6)	F3	COGO	(7)		F4 Road	(8)		F1	F2	F3	F4
		[Program]	2/3	⇅																	
F1 Area/volume	(5)	F2																			
Remote Height	(6)	F3																			
COGO	(7)																				
F4 Road	(8)																				
F1	F2	F3	F4																		

<p>○2 After finishing the pre-settings (know more details at the beginning of chapter 5), press [F4] to start Area/volume app.</p>	<p>[F4] or [4]</p>	<table border="1"> <tr> <td colspan="4">[Area/volume]</td> </tr> <tr> <td>[*] F1</td> <td>Set Job</td> <td>(1)</td> <td></td> </tr> <tr> <td>[*] F2</td> <td>Set STA</td> <td>(2)</td> <td>[*] F3</td> </tr> <tr> <td></td> <td>Set B.S.</td> <td>(3)</td> <td></td> </tr> <tr> <td>F4</td> <td>Start</td> <td>(4)</td> <td></td> </tr> <tr> <td>F1</td> <td>F2</td> <td>F3</td> <td>F4</td> </tr> </table>	[Area/volume]				[*] F1	Set Job	(1)		[*] F2	Set STA	(2)	[*] F3		Set B.S.	(3)		F4	Start	(4)		F1	F2	F3	F4																				
[Area/volume]																																														
[*] F1	Set Job	(1)																																												
[*] F2	Set STA	(2)	[*] F3																																											
	Set B.S.	(3)																																												
F4	Start	(4)																																												
F1	F2	F3	F4																																											
<p>○3 To measure the points of the polygon, you will get the area result once the points are more than 3, while you will also get the 3D result if you had defined the 3D surface.</p> <p>[DIST]: To measure the range from object point to the station. [REC]: To record the horizontal info</p> <p>[Find]: To search the points in the point library.</p> <p>[List]: To show the points</p> <p>[Coord.]: To input the coordinates manually by keyboard. [Dec PT]: To delete the current point</p> <p>[BreakLn] : To measure or select the points on the break line for volume calculation.</p> <p>[3D]: To defined the reference plane, for projection calculation</p>	<p>F4+ F1</p> <p>F4+ F2</p> <p>F4+ F3</p>	<table border="1"> <tr> <td colspan="4">[ Area/ volume]</td> </tr> <tr> <td>Pt. :</td> <td>T.H. :</td> <td>1</td> <td></td> </tr> <tr> <td>- :</td> <td></td> <td>1.500 m</td> <td></td> </tr> <tr> <td>PT Cou nt:</td> <td></td> <td>0</td> <td></td> </tr> <tr> <td>Area :</td> <td></td> <td>0.000m<sup>2</sup></td> <td></td> </tr> <tr> <td>ALL</td> <td>EDM</td> <td>Result</td> <td></td> </tr> <tr> <td>DIST</td> <td>REC</td> <td>Find</td> <td></td> </tr> <tr> <td>List</td> <td>Coord.</td> <td>Dec</td> <td></td> </tr> <tr> <td></td> <td></td> <td>PT</td> <td></td> </tr> <tr> <td>BreakL</td> <td>3D</td> <td>Dec</td> <td></td> </tr> <tr> <td></td> <td></td> <td>PT</td> <td></td> </tr> </table>	[ Area/ volume]				Pt. :	T.H. :	1		- :		1.500 m		PT Cou nt:		0		Area :		0.000m <sup>2</sup>		ALL	EDM	Result		DIST	REC	Find		List	Coord.	Dec				PT		BreakL	3D	Dec				PT	
[ Area/ volume]																																														
Pt. :	T.H. :	1																																												
- :		1.500 m																																												
PT Cou nt:		0																																												
Area :		0.000m <sup>2</sup>																																												
ALL	EDM	Result																																												
DIST	REC	Find																																												
List	Coord.	Dec																																												
		PT																																												
BreakL	3D	Dec																																												
		PT																																												
<p>○4 On Area/volume interface</p>	<p>F3</p>	<table border="1"> <tr> <td colspan="4">[ Area--Result]</td> </tr> </table>	[ Area--Result]																																											
[ Area--Result]																																														



Press the key of F3 to select  
Result function. To display the  
2D result(area, perimeter) and  
3D result

[Area(2D)]: To show the area

[Area(3D)]: To show the area

PT Count :	3
Area :	12.36 2 m2
Area :	0.00 1 ha
DTM-V :	
Perimeter:	3.32 8 m3 15. 654m

New	Graph	NEXT	Add
Area			PT

<p>[DTM-GRD]: To calculate the ground defined area by TIN method.</p> <p>[BL-Area]: To calculate the ground defined by the break line by TIN method.</p> <p>[DTM-V-I]: To calculate volume by TIN method</p> <p>[EXPAND-R]: expansion rate, to give a ratio of the volume A to volume B, Volume A is the actual volume while volume B is the volume after the earthwork.</p> <p>[DTM-V-II]: To calculate the volume of earth work [DENSITY]: The Density of the object.</p> <p>[WEIGHT]: The total weight of the object(ton)</p>		<div data-bbox="890 253 1326 658"> <p>[ 3D survey result]</p> <p>PT Count : 3</p> <p>Area : 12.362 m2</p> <p>Area : 0.001 ha</p> <p>DTM-V : 3.328 m3</p> <p>Perimeter: 15.654 m</p> <p>New Area NEXT Add</p> <p>Graph PT</p> </div> <div data-bbox="890 667 1326 1117"> <p>[ volume1--result]</p> <p>DTM_GRD : 100.000 m2</p> <p>BL-AREA : 0.000 m2</p> <p>DTM-V-I : 0.000 m3</p> <p>EXPAND-R : 1.000</p> <p>DTM-V-II : 0.000 m3</p> <p>New Area NEXT Add</p> <p>Graph PT</p> </div> <div data-bbox="890 1126 1326 1514"> <p>[ volume2--result]</p> <p>DENSITY : 1.000 WEIGHT : 0.000000</p> <p>New Area NEXT Add</p> <p>Graph PT</p> </div>
--	--	--

'''In all of the above operation, press [ESC] to return to the previous screen.

## 10. Remote Height

Remote Height is an application used to measure the height to the target (such as electric cable, bridge, etc.) where can't be set prism.

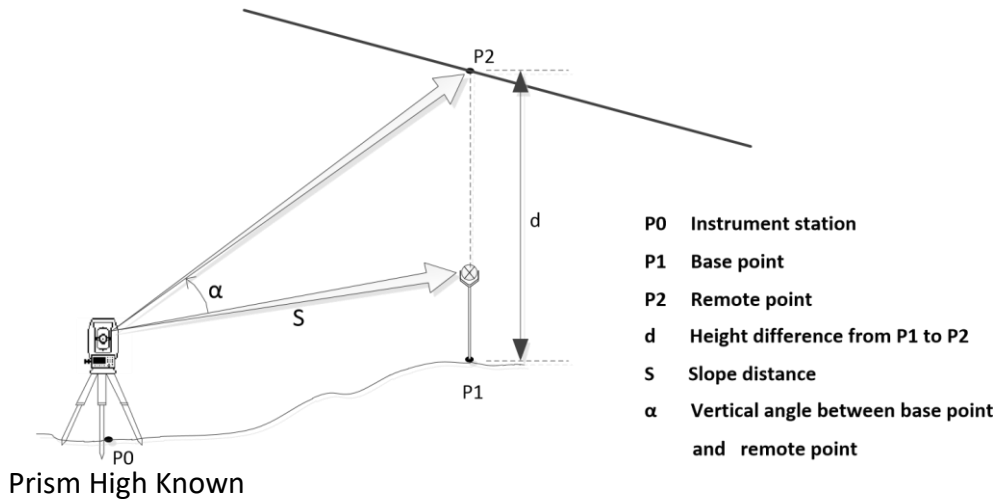

If the high of prism is known, the calculation formula of the remote height is:

$$H = S * \cos\alpha_1 * \tan\alpha_2 - S * \sin\alpha_1 + V$$

H Height difference between the base point and the remote point V



Prism High  $\alpha_1$  Vertical angle to prism  $\alpha_2$  Vertical angle to target

Steps	Key	Display
<p>O1 Select "Program" from the [Main Menu] window, then press [PAGE] switch to second program press [F2] or number key</p>	<p>[PAGE] + [F2] F3 F4</p>	
<p>[6] to enter the Area application.</p> <p>O2 After finishing the pre-settings (know more details at the beginning of chapter 5), [F4] [Base Pt.]</p>	<p>[6] F1 F2 F3 F4 [*] F3 [*] F3</p>	
<p>press [F2] or number key window to start Remote Height app. F1 F2 F3 [F4]</p> <p>O3 Move the prism just standing</p>	<p>[F4] F1 F2 F3 F4</p>	
		<p>below the remote point, then aim at the prism after input the prism high and press</p>

[F1] (ALL) or [F2] + [F3] (DIST + REC) to finish the base point measuring. Then enter the [REM PT] window.

[Base Pt.]  
Aim and meas.  
Base PT!

[F1] Base Pt. : 1 or T  
T.H. : 1.500m  
[F2] — : 4.082m  
+  
[F3] ALL DIST REC EDM H.T.?

<p>O4 Turn the instrument telescope aimed at remote point and press [F4] to finish current remote point measuring. Press [F1] to re-set the base point.</p>	<p>[F4]</p>	<p>[ R EAMi mP Ta] nd meas. target Base Pt. : 1  REM PT : 2  — : 4.082m  — : 2.430m Z : 3.849m Base Pt. <input type="text"/> <input type="text"/> OK</p>
---	-------------	---

## 10.1 Prism High Unknown

If the high of prism is unknown, the calculation formula of the remote height is:

$$H = S * \cos\alpha_1 * \tan\alpha_2 - S * \sin\alpha_1 * \tan\alpha_3$$

H Height difference between the base point and the remote point

V Prism High

S Slope distance between instrument and prism  $\alpha_1$

Vertical angle to prism

$\alpha_2$  Vertical angle to target point (remote point)

$\alpha_3$  Vertical angle to base point

Steps	Key	Display
① Select "Program" from the [Main Menu] window, then press [PAGE] switch to second program list and press [F2] or number key [6] to enter the Area application.	[PAGE] + [F2] or [6]	
② After finishing the pre-settings (know more details at the beginning of chapter 5), press [F4] to enter the [Base Pt.] window to start Remote Height app.	[F4]	
③ In [Base Pt.] window, press [F4] to second page of function keys, then press [F2] (H.T.?) switch to the situation of prism high unknown to start measuring.	[F4] + [F2]	

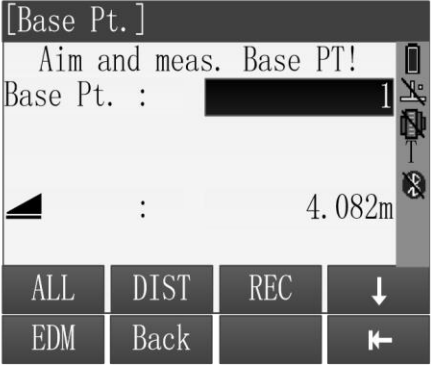
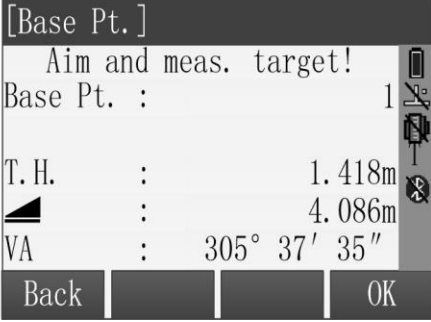
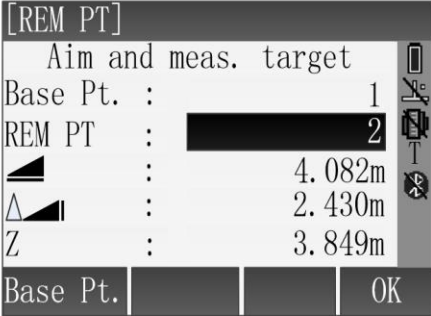
<p>④ Move the prism just standing below the remote point, then aim at the bottom of prism rod and press [F1] (ALL) or [F2] + [F3] (DIST + REC) to finish the base point measuring.</p>	<p>[F1] or [F2]+[F3]</p>	
<p>⑤ Turn the instrument telescope aimed at prism and press [F4] to measure the prism high. Then enter the [REM PT] window.</p>	<p>[F4]</p>	
<p>⑥ Turn the instrument telescope aimed at remote point and press [F4] to finish current remote point measuring. Press [F1] to re-set the base point.</p>	<p>[F4]</p>	

## 11. COGO

COGO(Coordinate Geometry)is an application used to perform coordinate geometry calculations by the preset conditions such as , coordinates of points, bearings between points and distance between points.

The COGO calculation methods include:

- ✧ Inverse and Traverse
- ✧ Intersections
- ✧ Offset
- ✧ Extension

### 11.1 Traverse

Use the traverse sub application to calculate the plane coordinate of a new point using the bearing and distance from a known point. Offset is optional.

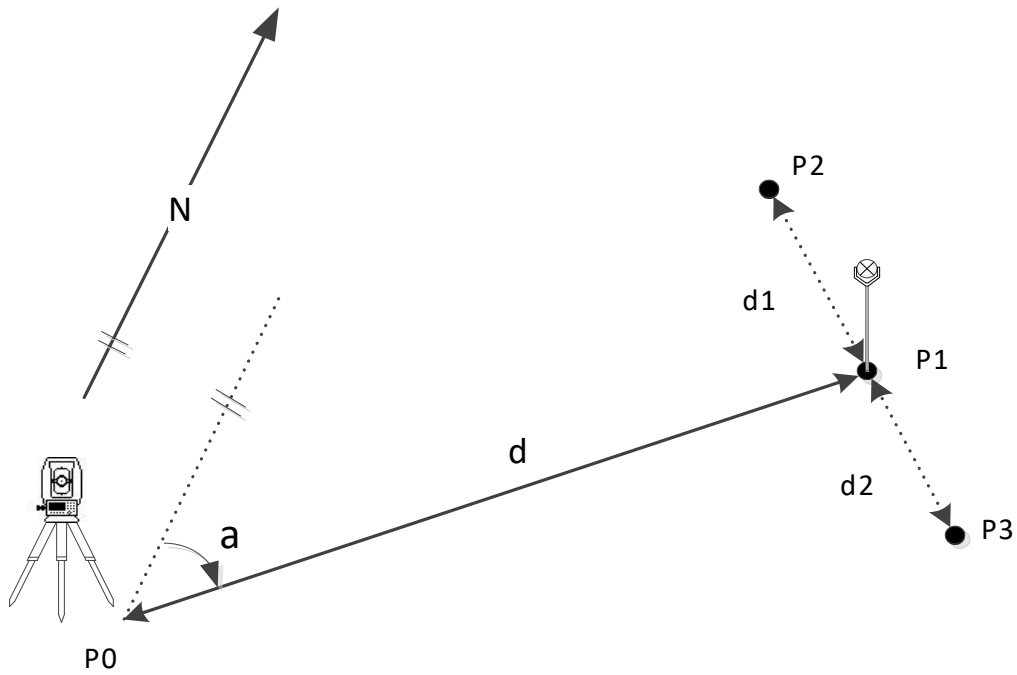

Figure 11.1 Traverse Diagram



**Known**

P0 known point a Direction  
 from P1 to P2 d Distance  
 between P1 and P2 d1 Positive  
 offset to the right d2 Negative  
 offset to the left

**Unknown**

P1 COGO point without offset  
 P2 COGO point with negative offset  
 P3 COGO point with positive offset

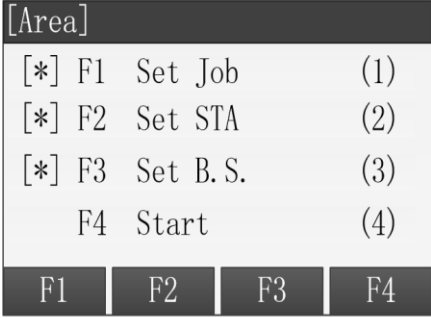
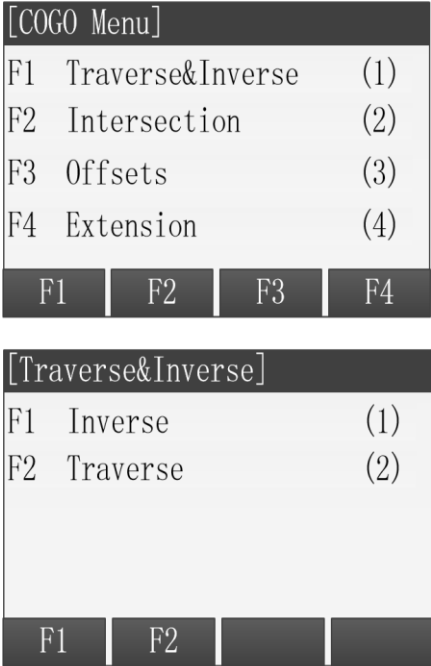
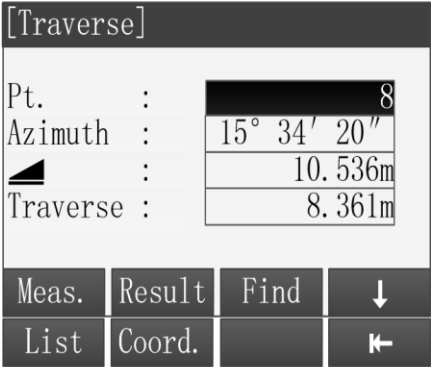
Steps	Key	Display						
O1 Select "Program" from the [Main Menu] window, then press [PAGE] switch to second program list and press [F1] or number key [7] to enter the COGO application.	[PAGE] + [F2] or [7]	[Program] 2/3						
		<table border="1"> <tr> <td>F1 Area (5)</td> <td>F2 Remote Height (6)</td> <td>F3 COGO (7)</td> <td>F4 Road (8)</td> </tr> <tr> <td>F1</td> <td>F2</td> <td>F3</td> <td><b>F4</b></td> </tr> </table>	F1 Area (5)	F2 Remote Height (6)	F3 COGO (7)	F4 Road (8)	F1	F2
F1 Area (5)	F2 Remote Height (6)	F3 COGO (7)	F4 Road (8)					
F1	F2	F3	<b>F4</b>					

<p>② After finishing the pre-settings (know more details at the beginning of chapter 5), press [F4] to start COGO app.</p>	<p>[F4] or [4]</p>	
<p>③ In [COGO Menu] screen, press the [F1] or number key [1] enter the [Traverse &amp; Inverse] screen, press [F2] or [2] enter the traverse sub application.</p>	<p>[F1] or [1]  [F2] or [2]</p>	
<p>④ There are four ways to get the known point for traverse calculation.</p> <p>A: Input the name of known point in "Pt." field in [Traverse] screen and press [F1](Meas.) entry the [COGO Meas]</p> <p>Input prism height in the "T.H." field in [COGO-Meas], then aim the prism and press [F1] (ALL) or [F2] (DIST) + [F3] (REC) to measuring and saving the point for traverse calculation.</p>	<p>Input point name + [F1](Meas.)  [F1](ALL) or [F2](DIST) + [F3](REC)</p>	<p>A: Get the known point by COGO-Meas.</p>  <p>COGO-Meas.</p> 

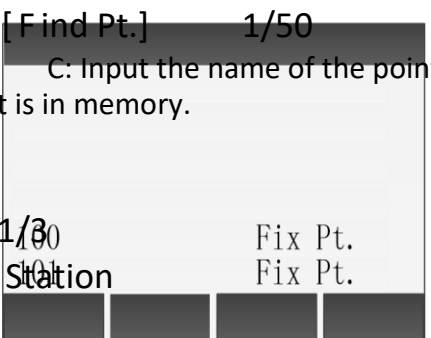
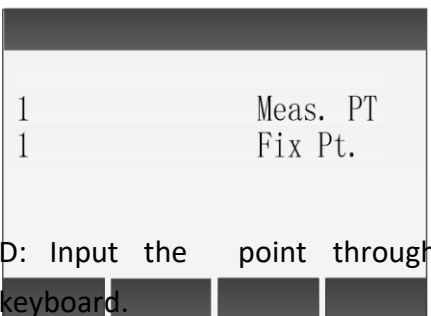
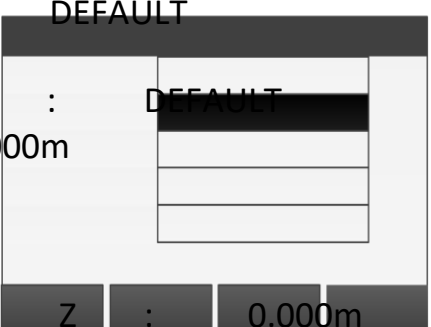
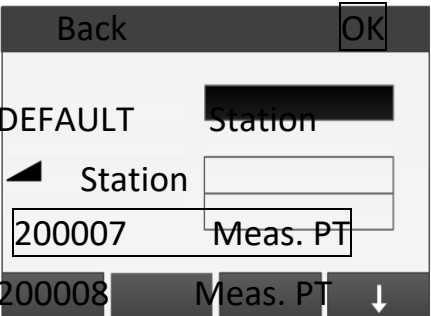

<p>B: Press [F1](List) in [Traverse]</p> <p>C: Input the name of known and find whether it is in memory. point and press [F3](Find) to find whether the point is in memory, if exist, then press</p>	<p>Find Pt.]</p> <p>+ 1</p> <p>[F3](Find)</p>	
<p>[F4](OK) to be selected for calculating; if not exist, then need to input or measure the point. View <span style="border: 1px solid black; padding: 2px;">Coord.</span> Job OK</p>	<p>+</p> <p>[F4](OK)</p>	
<p>D: Press [F2](Coord.) to input a known point that not exist in memory. E : 0.000m</p>	<p>[F2](Coord.)</p> <p>[Set STA]</p> <p>+ Job :</p> <p>Input Pt. :</p> <p>: 0.000m</p> <p>Coord.</p> <p>+</p>	
<p>screen, use the key [▲][▼] to select a Known point in the point list for traverse calculation, then press [F4](OK) to be selected.</p> <p>B: Select the</p>	<p>[F4](OK)</p> <p>[F1](List)</p> <p>+ STN1</p> <p>[F4](OK)</p>	

point by list in the memory.

View Coord. Job OK

O5 After setting known point, [▲]\[▼] [Traverse]  
 press [▼]\[▲] key to move focus + Pt. : 8  
 to the "AZ", "▲" and Input Azimuth : 15°34'20"  
 "Transverse" field, input the content - :10.536m  
 content, then press + Traverse : 8.361m  
 [F2](Result) to calculate and [F2] Meas. Result Find  
 show the traverse result.

<p>O6 Input the name of result point in the [Traverse Result] and press [F4](REC) to save the point.</p>	<p>[F4](REC)</p>	<table border="1"> <tr> <th colspan="3">[Traverse Result]</th> </tr> <tr> <td>Pt.</td> <td>: N</td> <td>: E</td> <td>:</td> </tr> <tr> <td></td> <td>10</td> <td></td> <td></td> </tr> <tr> <td></td> <td>6.369m</td> <td></td> <td></td> </tr> <tr> <td></td> <td>3.536m</td> <td></td> <td></td> </tr> <tr> <td></td> <td></td> <td></td> <td>REC</td> </tr> </table>	[Traverse Result]			Pt.	: N	: E	:		10				6.369m				3.536m						REC
[Traverse Result]																									
Pt.	: N	: E	:																						
	10																								
	6.369m																								
	3.536m																								
			REC																						

''' In all of the above operation, press [ESC] to return to the previous screen.

''' The result point is plane data.

## 11.2 Inverse

Use the inverse sub application to calculate the distance, direction, height difference between two known points.

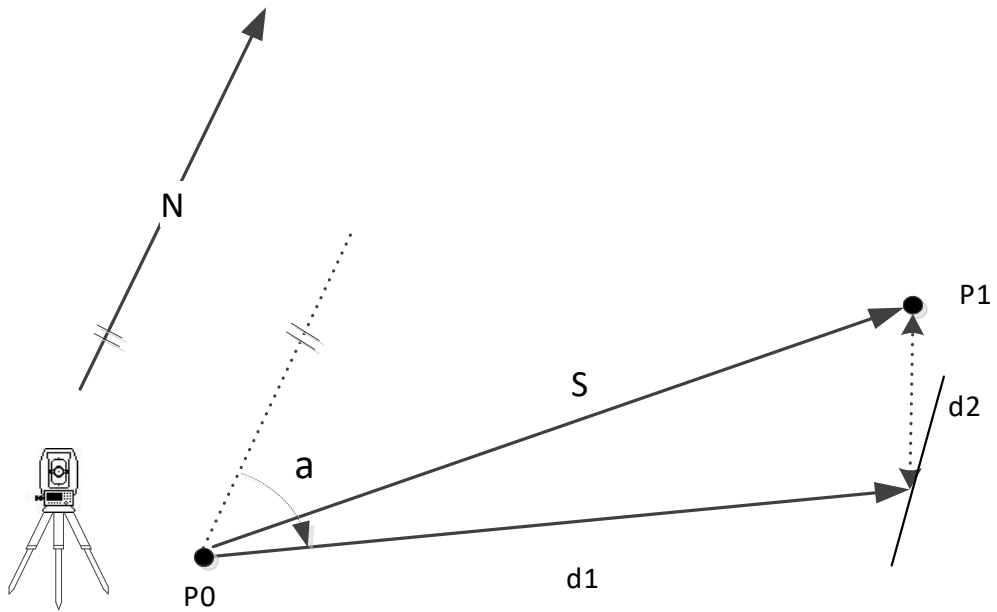

Figure 11.2 Inverse Diagram

**Known**

P0 First known point

P1 Second known point

**Unknown**

a Direction from P0 to P1 S

Slope distance between P0 and P1 d1

Horizontal distance between P0 and P1

d2 Height difference between P0 and P1

Steps	key	Display
<p>① In the [Traverse &amp; Inverse] screen, press [F1] or [1] to enter the Inverse sub application.</p>	<p>[F1] or [1]</p>	
<p>② There are four ways to get the known point for inverse calculation.</p> <p>A: Input the name of known point in "Pt." field in [Traverse] screen and press [F1](Meas.) entry the [COGO Meas]</p> <p>Input prism height in the "T.H." field on [COGO-Meas], then aim the prism and press [F1](ALL) or [F2](DIST) + [F3](REC) to measuring and saving the point for inverse calculation.</p>	<p>Input point name +[F1](Meas.)</p> <p>[F1](ALL) Or [F2](DIST) + [F3](REC)</p>	<p>A: Get the known point by COGO-Meas</p> <p>COGO-Meas.</p>
<p>B: Press [F1](List) in [Traverse] screen, use the key [▲][▼] to select a Known point in the point list for inverse calculation, then press [F4](OK) to be done.</p>	<p>[F1](List) + [F4](OK)</p>	<p>B: Select the point by list in the instrument.</p>

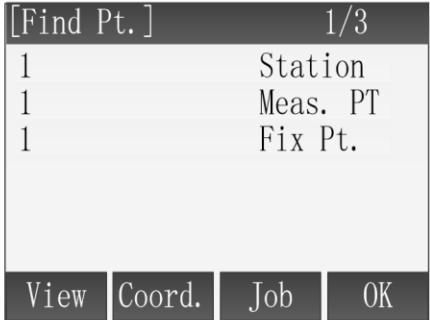
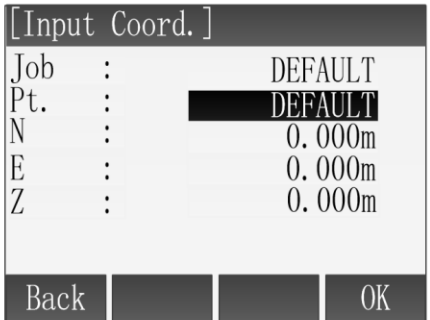
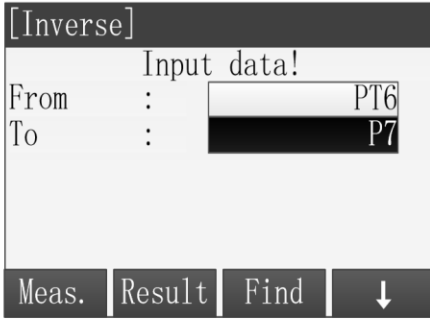
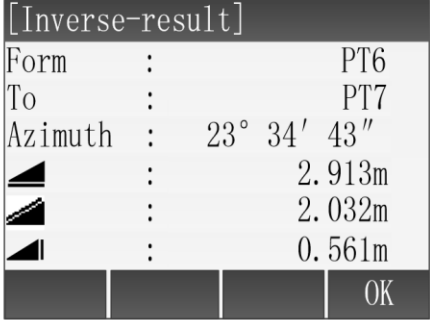
<p>C: Input the name of known point and press [F3](Find) to find whether the point is in memory, if exist, then press [F4](OK) to be selected for calculating; if not exist, then need to input or measure the point.</p>	<p>Input name + [F3](Find) + [F4](OK)</p>	<p>C: Input the name of the point and find whether it is in memory.</p> 
<p>D: Press [F2](Coord.) to input a known point that not exist in memory.</p>	<p>[F2](Coord.) + Input Coord. + [F4](OK)</p>	<p>D: Input the point through keyboard.</p> 
<p>③ After setting the first known point then use [▼][▲] move the focus to "To" field to set the second known point, then press [F2](Result) to calculate the inverse point and show the result.</p>	<p>[▼][▲]+ [F2]</p>	
<p>④ Input the name of result point in the [Traverse Result] and press [F4](REC) to save the point.</p>	<p>[F4](REC)</p>	

※ In all of the above operation, press [ESC] to return to the previous menu.

” The result point is plane data.

---

### 11.3 Bearing-Bearing Intersection

Use the bearing-bearing (BRG-BRG) sub application to calculate the intersection point of two lines. A line is defined by a point and a direction.

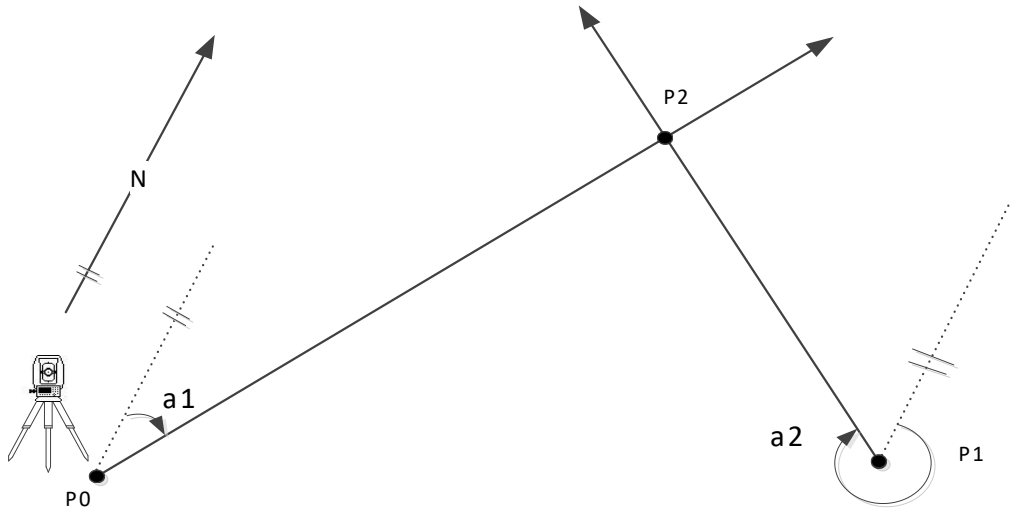

Figure 11.3 BRG-BRG Diagram

#### Known





- P0 First known point
- P1 Second known point
- a1 Direction from P0 to P2
- a2 Direction from P1 to P2

#### Unknown

- P3 COGO point

Steps	key	Display
-------	-----	---------

<p>O1 In [COGO Menu] screen, press the [F2] or number key [2] to enter the [Intersection] screen. Then press [F1] or [1] to enter the BRG-BRG sub application.</p>	<p>[F2] or [2]</p> <p>[F1] or [1]</p>	<table border="1"> <tr> <td colspan="4"><b>[COGO Menu]</b></td> </tr> <tr> <td>F1</td> <td>Traverse&amp;Inverse</td> <td>(1)</td> <td></td> </tr> <tr> <td>F2</td> <td>Intersection</td> <td>(2)</td> <td></td> </tr> <tr> <td>F3</td> <td>Offsets</td> <td>(3)</td> <td></td> </tr> <tr> <td>F4</td> <td>Extension</td> <td>(4)</td> <td></td> </tr> <tr> <td>F1</td> <td>F2</td> <td>F3</td> <td><b>F4</b></td> </tr> </table> <table border="1"> <tr> <td colspan="4"><b>[Intersection]</b></td> </tr> <tr> <td>F1</td> <td>BRG-BRG</td> <td>(1)</td> <td></td> </tr> <tr> <td>F2</td> <td>BRG-DST</td> <td>(2)</td> <td></td> </tr> <tr> <td>F3</td> <td>DST-DST</td> <td>(3)</td> <td></td> </tr> <tr> <td>F4</td> <td>LNLN</td> <td>(4)</td> <td></td> </tr> <tr> <td>F1</td> <td>F2</td> <td>F3</td> <td><b>F4</b></td> </tr> </table>	<b>[COGO Menu]</b>				F1	Traverse&Inverse	(1)		F2	Intersection	(2)		F3	Offsets	(3)		F4	Extension	(4)		F1	F2	F3	<b>F4</b>	<b>[Intersection]</b>				F1	BRG-BRG	(1)		F2	BRG-DST	(2)		F3	DST-DST	(3)		F4	LNLN	(4)		F1	F2	F3	<b>F4</b>
<b>[COGO Menu]</b>																																																		
F1	Traverse&Inverse	(1)																																																
F2	Intersection	(2)																																																
F3	Offsets	(3)																																																
F4	Extension	(4)																																																
F1	F2	F3	<b>F4</b>																																															
<b>[Intersection]</b>																																																		
F1	BRG-BRG	(1)																																																
F2	BRG-DST	(2)																																																
F3	DST-DST	(3)																																																
F4	LNLN	(4)																																																
F1	F2	F3	<b>F4</b>																																															

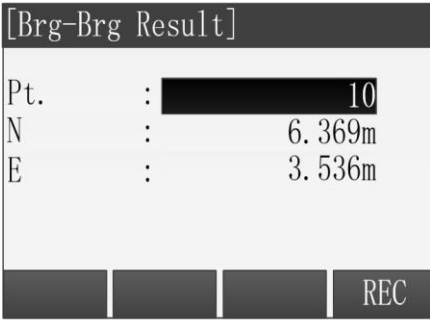
<p>② Input the name of first point in "PT1" field.</p> <p>※ There are four ways to get the known point for BRG-BRG calculation. Please refer to the step ② in the "COGO Traverse".</p>	<p>Input name of first point</p>	
<p>③ Move the focus to "AZ1" by using [▼] and input the first bearing after set first point.</p>	<p>[▼] + Input first bearing</p>	
<p>④ Move the focus to "PT2" by using [▼] to setting second point.</p>	<p>[▼] + Set second point</p>	
<p>⑤ Move the focus to "AZ2" by using [▼] and input the second bearing after set second point.</p>	<p>[▼] + Input second bearing</p>	
<p>⑥ When all of the data are entered correctly, press [F2](Result) to calculate the intersection point and show the result.</p> <p>Input the name of result point</p>	<p>[F2]</p>	



in the [BRG-BRG Result] and press [F4](REC) to save the point.		
--	--	--

''' In all of the above operation, press [ESC] to return to the previous menu.

''' The result point is plane data.

## 11.4 Bearing-Distance Intersection

Use the bearing-distance (BRG-DST) sub application to calculate the intersection point of a line and a circle. The line is defined by a point and a direction. The circle is defined by the center point and the radius. The result may be have 1 intersection point, may be have 2 points, or may be have no one.

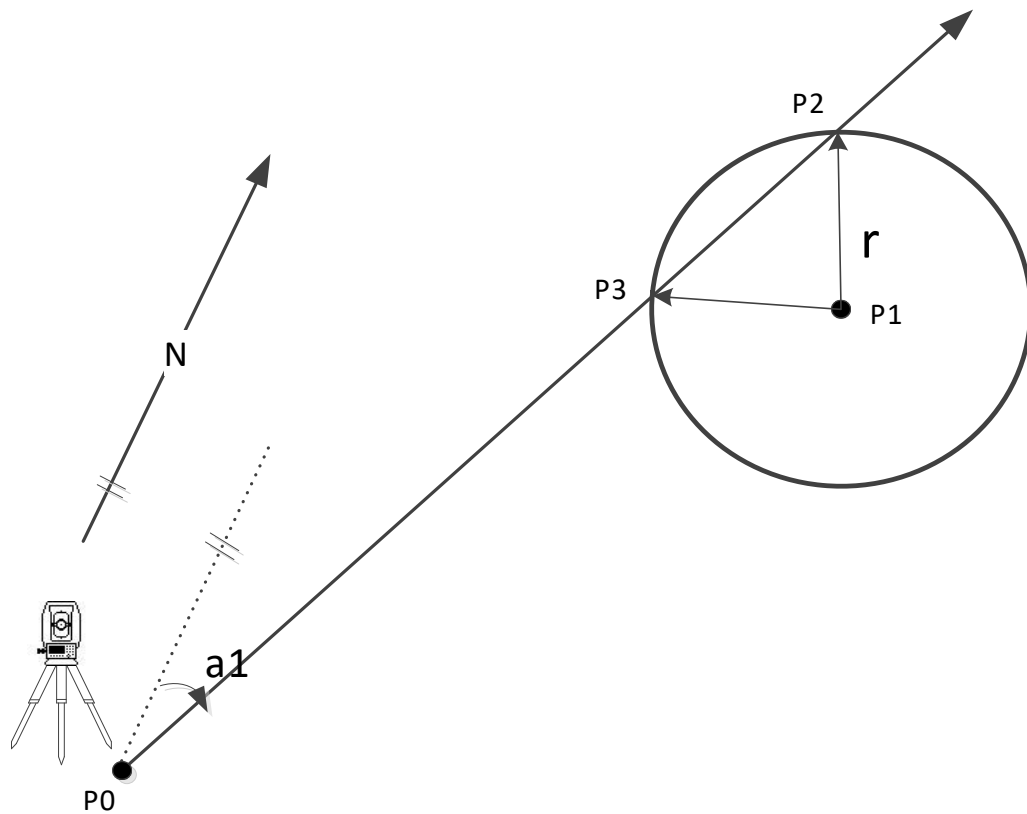

Figure 11.4 BRG-DST Diagram

### Known

P0 First known point

P1 Second known point

a1 Direction from P0 to P2 or P3

r Radius, as the distance from P1 to P2 or P3

Steps	key	Display
① In the [Intersection] screen, press [F2] or [2] to enter the BRG-DST subapplication.	[F2] or [2]	
② Input the name of first point in "PT1" field.  ※ There are four ways to get the known point for BRG-DST calculation. Please refer to the step ② in the "COGO Traverse".	Input name of first point	
③ Move the focus to "AZ1" by using [▼] and input the bearing after set first point.	[▼] + Input bearing	
④ Move the focus to "PT2" by using [▼] to setting second point.	[▼] + Set second point	

#### Unknown

- P2 First COGO point
- P3 Second COGO point

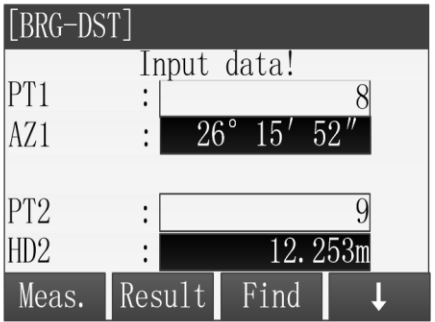
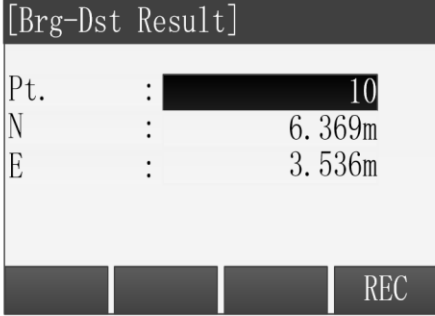
<p>⑤ Move the focus to “HD2” by using [▼] and input the radius after set second point.</p>	<p>[▼] + Input radius</p>	
<p>⑥ When all of the data are entered correctly, press [F2] (Result) to calculate the intersection point and show the results.</p> <p>Input the name of result point in the [BRG-DST Result] and press [F4](REC) to save the point.</p> <p>Press [F1] to switch to view results.</p>	<p>[F2]</p>	

※ In all of the above operation, press [ESC] to return to the previous menu.

” The result point is plane data.

## 11.5 Distance-Distance Intersection

Use the distance-distance (DST-DST) sub application to calculate the intersection point of two circles. The circles are defined by the known point as the center point and the distance from the known point to the COGO point as the radius. The result may be have 1 intersection point, may be have 2 points, or may be have no one.

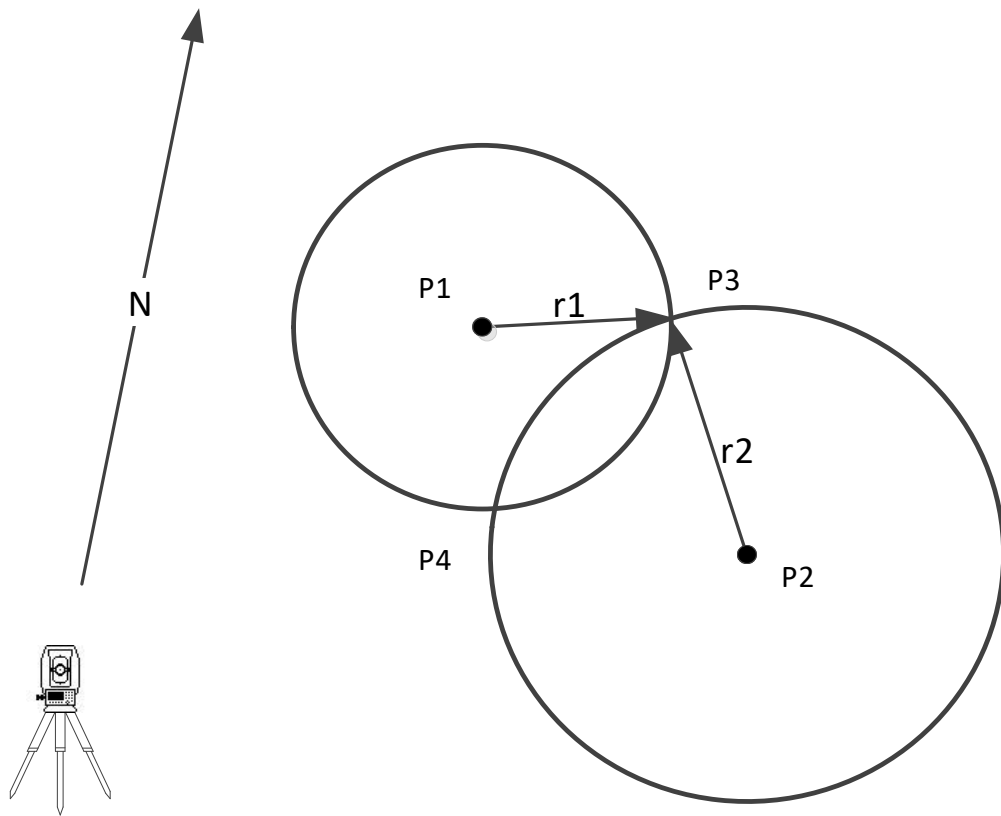

Figure 11.5 DST-DST Diagram

**Known**

- P1 First known point
- P2 Second known point
- r1 Radius, as the distance from P1 to P3 or P4
- r2 Radius, as the distance from P2 to P3 or P4

**Unknown**

- P3 First COGO point
- P4 Second COGO point

Steps	key	Display
-------	-----	---------

<p>O1 In the [Intersection] screen, press [F3] or [3] to enter the DST-DST sub application.</p>	<p>[F3] or [3]</p>	<table border="1"> <tr> <td colspan="4" data-bbox="879 248 1310 300"><b>[Intersection]</b></td> </tr> <tr> <td data-bbox="879 300 986 344">F1</td> <td data-bbox="986 300 1209 344">BRG-BRG</td> <td data-bbox="1209 300 1310 344">(1)</td> <td></td> </tr> <tr> <td data-bbox="879 344 986 389">F2</td> <td data-bbox="986 344 1209 389">BRG-DST</td> <td data-bbox="1209 344 1310 389">(2)</td> <td></td> </tr> <tr> <td data-bbox="879 389 986 434">F3</td> <td data-bbox="986 389 1209 434">DST-DST</td> <td data-bbox="1209 389 1310 434">(3)</td> <td></td> </tr> <tr> <td data-bbox="879 434 986 479">F4</td> <td data-bbox="986 434 1209 479">LNLN</td> <td data-bbox="1209 434 1310 479">(4)</td> <td></td> </tr> <tr> <td data-bbox="879 479 986 524">F1</td> <td data-bbox="986 479 1094 524">F2</td> <td data-bbox="1094 479 1203 524">F3</td> <td data-bbox="1203 479 1310 524"><b>F4</b></td> </tr> </table>	<b>[Intersection]</b>				F1	BRG-BRG	(1)		F2	BRG-DST	(2)		F3	DST-DST	(3)		F4	LNLN	(4)		F1	F2	F3	<b>F4</b>
<b>[Intersection]</b>																										
F1	BRG-BRG	(1)																								
F2	BRG-DST	(2)																								
F3	DST-DST	(3)																								
F4	LNLN	(4)																								
F1	F2	F3	<b>F4</b>																							

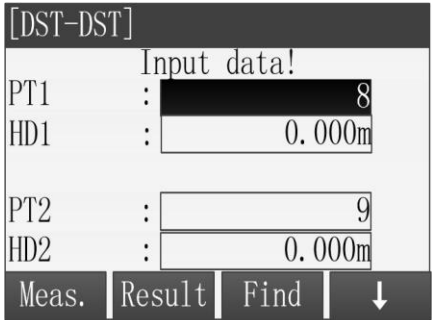
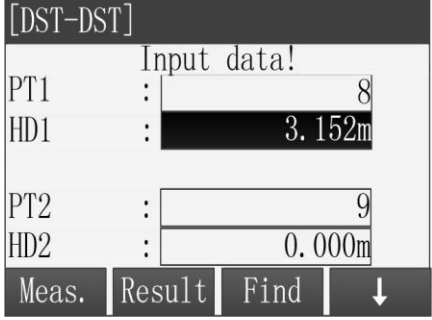
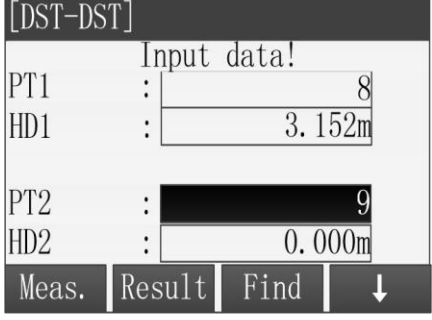
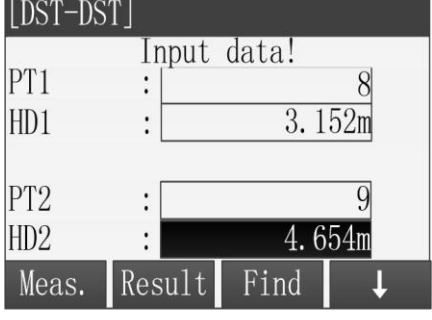
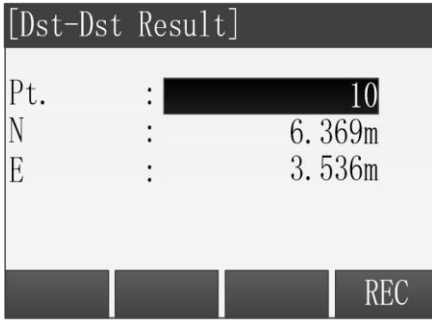
<p>② Input the name of first point in “PT1” field.</p> <p>※ There are four ways to get the known point for DST-DST calculation. Please refer to the step ② in the “COGO Traverse”.</p>	<p>Set first point</p>	
<p>③ Move the focus to “HD1” by using [▼] key and input the first radius after set first point.</p>	<p>[▼] + radius</p>	
<p>④ Move the focus to “PT2” by using [▼] to setting second point.</p>	<p>[▼] + Set second point</p>	
<p>⑤ Move the focus to “HD2” by using [▼] and input the second radius after set second point.</p>	<p>[▼] + Input second radius</p>	
<p>⑥ When all of the data are entered correctly, press [F2](Result) to calculate the intersection point and show the results.</p> <p>Input the name of result point</p>	<p>[F2]</p>	

---

in the [DST-DST Result] and press [F4](REC) to save the point.  Press [F1] to switch to view results.		
--	--	--

"" In all of the above operation, press [ESC] to return to the previous menu. "" The result point is plane data.

---

## 11.6 Line-Line Intersection

Use the line-line (LNLN) sub application to calculate the intersection point of two lines. A line is defined by two points.

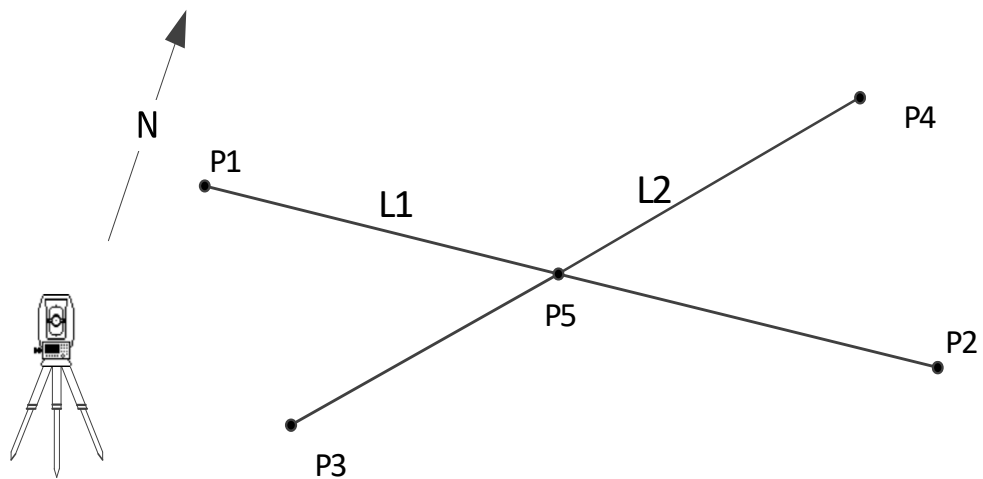

Figure 11.6 LNLN Diagram

### Known

- P1 First known point
- P2 Second known point
- P3 Third known point
- P4 Fourth known point

L1 Line from P1 to P2

L2 Line from P3 to P4

### Unknown

- P5 COGO point

Steps	key	Display
-------	-----	---------

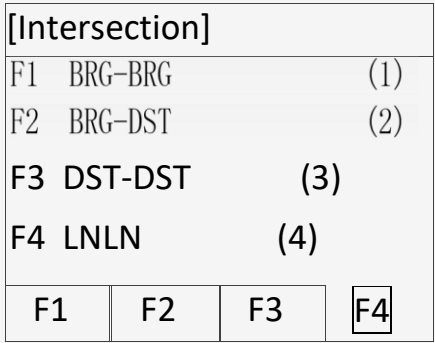
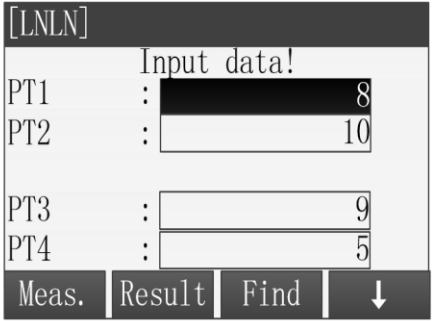
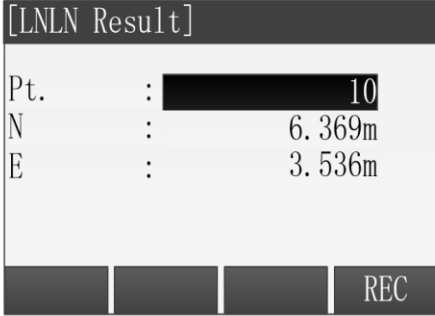

<p>○1 In the [Intersection] screen, press [F4] or [4] to enter the LNLN sub application.</p>	<p>[F4] or [4]</p>	
<p>② Set the known point one by one. ※ There are four ways to get the known point for LNLN calculation. Please refer to the step ② in the “COGO Traverse”.</p>	<p>Set the known points</p>	
<p>③ When all of the points are to calculate the intersection point and show the results.  Input the name of result point in the [LNLN Result] and press [F4](REC) to save the point.</p>	<p>[F2]</p>	

※ In all of the above operation, press [ESC] to return to the previous menu.

” The result point is plane data.

## 11.7 Distance-Offset

Use the distance-offset (DistOff) sub application to calculate the foot point (COGO point) coordinates of offset point to baseline, the baseline is defined by two known points, and the longitudinal and offset distance of the offset point in relation to the line.

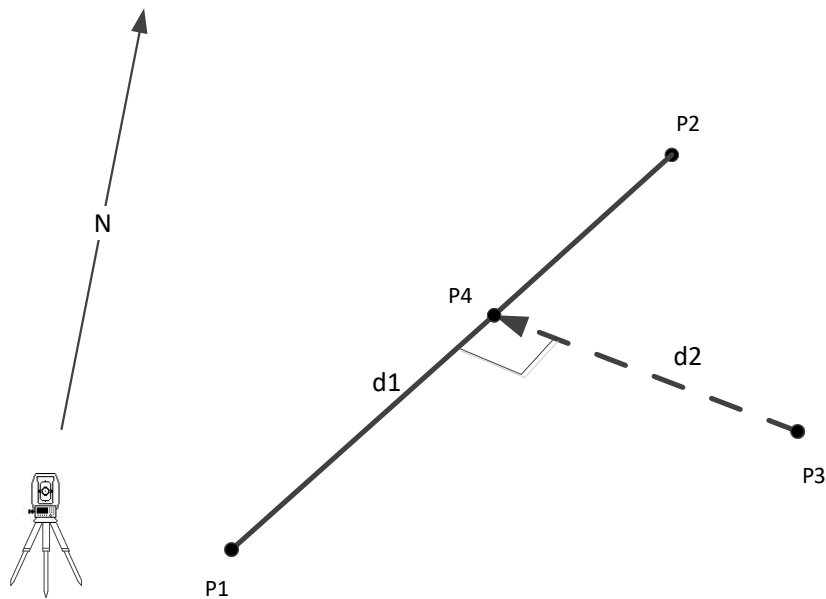

Figure 11.7 DistOff Diagram

**Known**

- P1 Start point
- P2 End point
- P3 Offset point

**Unknown**

- d1  $\Delta$ line d2
- $\Delta$ Offset
- P4 COGO point (foot point)

Steps	key	Display												
<p>○1 In [COGO Menu] screen, press the [F3] or number key [3] enter the [Offsets] screen, then press [F1] or [1] enter the DistOff sub application.</p>	<p>[F3] or [3]</p>	<p>[COGO Menu]</p> <table border="1"> <tr> <td>F1</td> <td>Traverse&amp;Inverse</td> <td>(1)</td> </tr> <tr> <td>F2</td> <td>Intersection</td> <td>(2)</td> </tr> <tr> <td>F3</td> <td>Offsets</td> <td>(3)</td> </tr> <tr> <td>F4</td> <td>Extension</td> <td>(4)</td> </tr> </table> <p>F1   F2   F3   <b>F4</b></p>	F1	Traverse&Inverse	(1)	F2	Intersection	(2)	F3	Offsets	(3)	F4	Extension	(4)
F1	Traverse&Inverse	(1)												
F2	Intersection	(2)												
F3	Offsets	(3)												
F4	Extension	(4)												

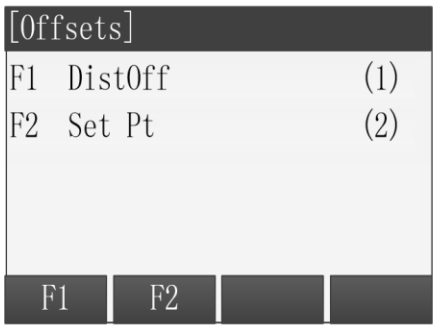
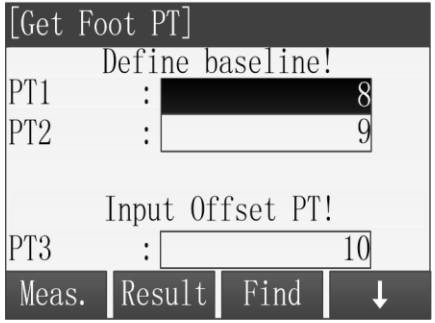
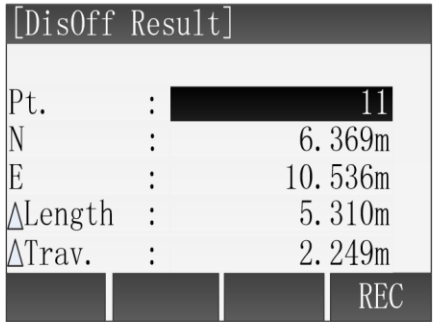
	[F1] or [1]	
<p>② Set the start point, end point and offset point one by one.</p> <p>※There are four ways to get the known point for DistOff calculation. Please refer to the step ② in the “COGO Traverse”.</p>	Set the known points	
<p>③ When all of the points are to calculate the intersection point and show the results.</p> <p>Input the name of result point in the [DistOff Result] and press [F4](REC) to save the point.</p>	[F2] + [F4]	

※ In all of the above operation, press [ESC] to return to the previous menu.

” The result point is plane data.

## 11.8 Set Point

Use the Set Point (Set Pt) sub application to calculate the coordinate of a new point in relation to a line from known longitudinal and offset distance.

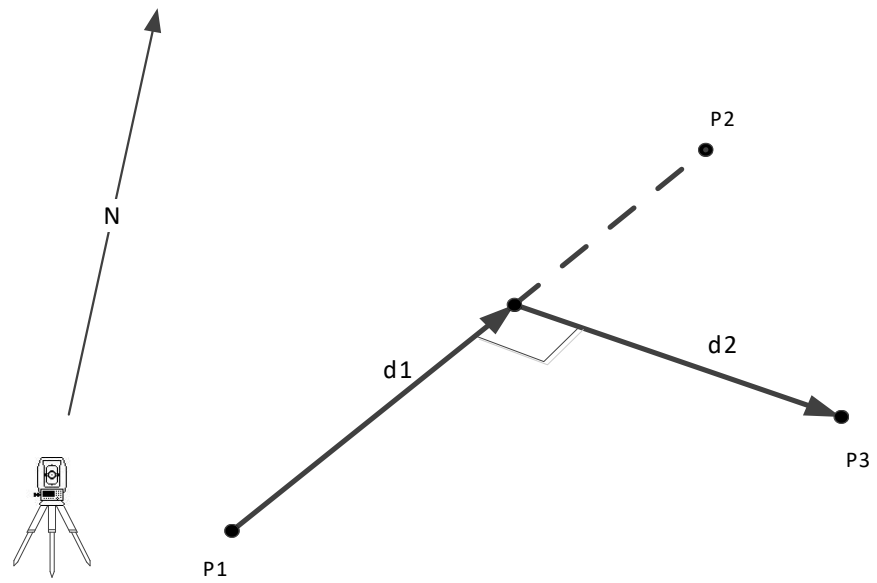

Figure 11.8 Set Point Diagram

**Known**

P1 Start Point

P2 End Point

d1  $\Delta$ line d2

$\Delta$ Offset

**Unknown**

P3 COGO point

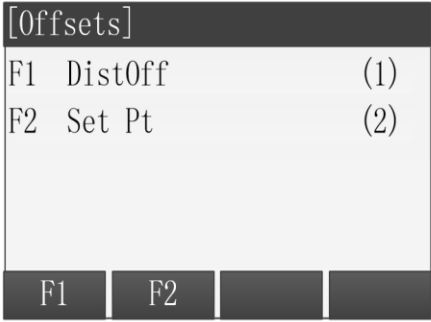
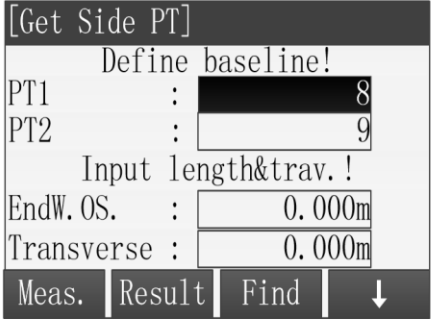
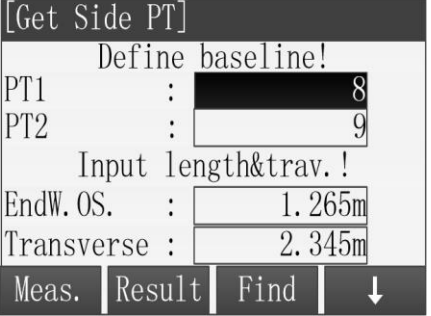
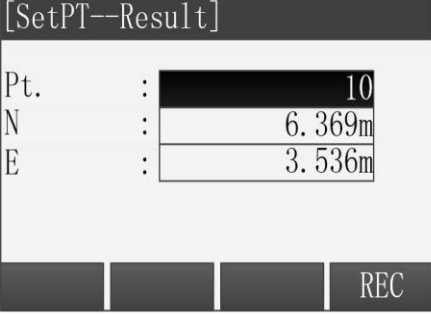
Steps	key	Display
<p>① In the [Offsets] screen, press [F2] or [2] to enter the Set Point sub application.</p>	<p>[F2] or [2]</p>	
<p>② Set the start point and end point. ※There are four ways to get the known point for Set Point calculation. Please refer to the step ② in the “COGO Traverse”.</p>	<p>Set known points</p>	
<p>③ Then baseline is defined, press [▼] key to move the focus down and input the longitudinal and offset distance.</p>	<p>[▼] + Input distance</p>	
<p>④ When all of the data are set correctly, press [F2](Result) to calculate the intersection point and show the results.  Input the name of result point in the [SetPT Result] and press [F4](REC) to save the point.</p>	<p>[F2]</p>	

※ In all of the above operation, press [ESC] to return to the previous menu.

''' The result point is plane data.

## 11.9 Extension

Use the Extension sub application to calculate the coordinate of extended point from a known baseline.

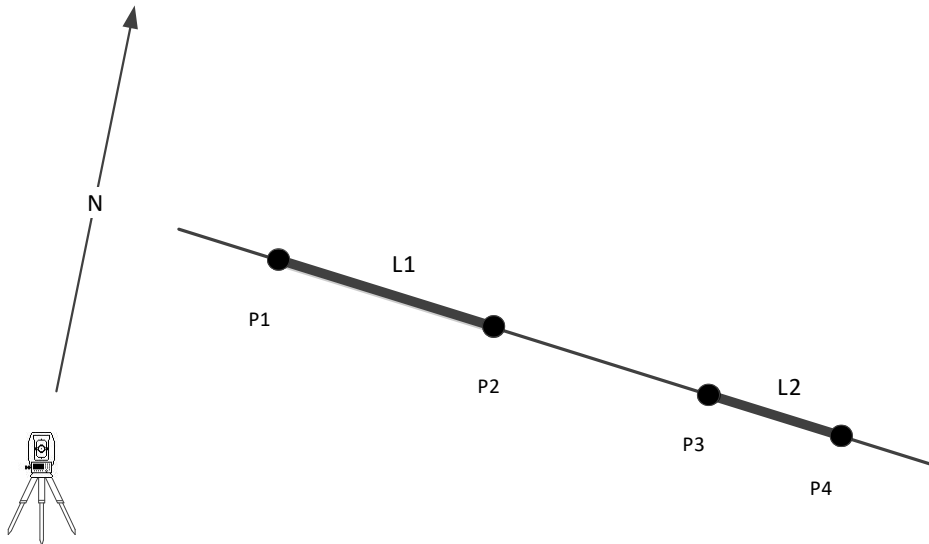

Figure 11.9 Extension Diagram

### Known

- P1 Baseline Start Point
- P2 Baseline End Point
- L1, L2 Extension Distance

### Unknown

- P2, P4 Extended COGO Point

Steps	Key	Display				
O1 In the [COGO Menu] screen, press the [F4] or number key [4] enter the [Extension] screen.	[F4] or [4]	<div style="border: 1px solid black; padding: 5px;"> <p>[COGO Menu]</p> <p>F1 Traverse&amp;Inverse (1)</p> <p>F2 Intersection (2)</p> <p>F3 Offsets (3)</p> <p>F4 Extension (4)</p> <table border="1" style="width: 100%; text-align: center;"> <tr> <td>F1</td> <td>F2</td> <td>F3</td> <td style="border: 2px solid black;">F4</td> </tr> </table> </div>	F1	F2	F3	F4
F1	F2	F3	F4			

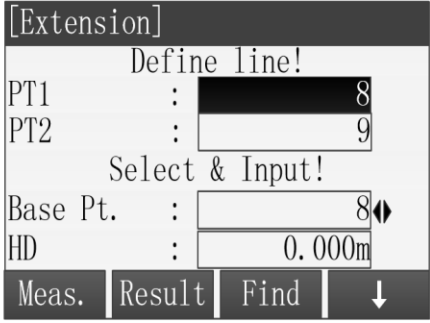
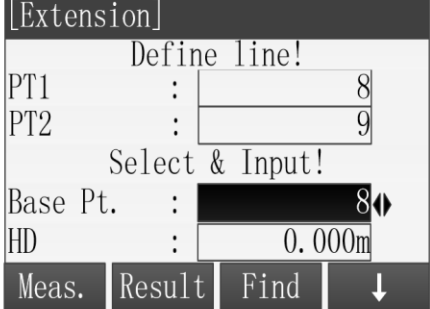
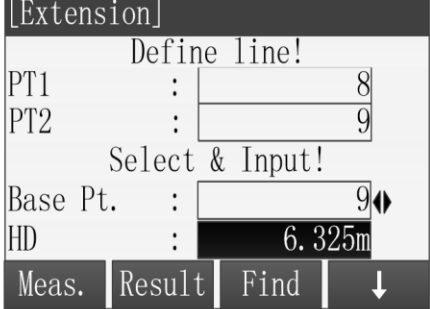
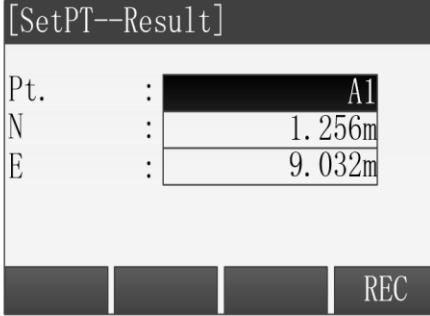
<p>② Set the baseline start point and end point.      ※ There are four ways to get the known point for Extension calculation. Please refer to the step ② in the “COGO Traverse”.</p>	<p>Set known points</p>	
<p>③ Then baseline is defined, press [▼] key to move the focus down and use [◀][▶] Key to select base point.</p>	<p>[▼] + [◀][▶]</p>	
<p>④ Then press [▼] key to move the focus down and input the extension distance in the “HD” field.</p>	<p>[▼] + Input distance</p>	
<p>⑤ When all of the data are set correctly, press [F2](Result) to calculate the intersection point and show the results.      Input the name of result point in the [Extension Result] and press [F4](REC) to save the point.</p>	<p>[F2]</p>	

※ In all of the above operation, press [ESC] to return to the previous menu.

” The result point is plane data.

## 12. Road

Road is an application used to measure or stake out points relative to a defined element. The element can be a line, curve or spiral. Chainage, incremental stake outs and offsets(left and right) are supported.

Setting job, setting station and setting backsight must be done before road define and staking out.

[Road]			
F1	Road Manage	(1)	
F2	HC list	(2)	
F3	Vert. curve list	(3)	
F4	Road Stakeout	(4)	
F1	F2	F3	F4

### 12.1 Road Manage

After setting up the job, station and back sight point, user can start to define the road path.

Steps	Key	Display																								
① Pressing key [F4] to start the road function after job setting, station setting and BS.	[F4]	<table border="1"> <tr> <td colspan="4">[Road]</td> </tr> <tr> <td>[*] F1</td> <td>Set Job</td> <td>(1)</td> <td></td> </tr> <tr> <td>[*] F2</td> <td>Set STA</td> <td>(2)</td> <td></td> </tr> <tr> <td>[*] F3</td> <td>Set B.S.</td> <td>(3)</td> <td></td> </tr> <tr> <td>F4</td> <td>Start</td> <td>(4)</td> <td></td> </tr> <tr> <td>F1</td> <td>F2</td> <td>F3</td> <td>F4</td> </tr> </table>	[Road]				[*] F1	Set Job	(1)		[*] F2	Set STA	(2)		[*] F3	Set B.S.	(3)		F4	Start	(4)		F1	F2	F3	F4
[Road]																										
[*] F1	Set Job	(1)																								
[*] F2	Set STA	(2)																								
[*] F3	Set B.S.	(3)																								
F4	Start	(4)																								
F1	F2	F3	F4																							
② Pressing key [F1] <b>Define road path.</b>	[F1]	<table border="1"> <tr> <td colspan="4">[Road]</td> </tr> <tr> <td>F1</td> <td>Define road path</td> <td>(1)</td> <td></td> </tr> <tr> <td>F2</td> <td>Road Stakeout</td> <td>(2)</td> <td></td> </tr> <tr> <td>F3</td> <td>Result. Setting out</td> <td>(3)</td> <td></td> </tr> <tr> <td>F4</td> <td>Transfer</td> <td>(4)</td> <td></td> </tr> <tr> <td>F1</td> <td>F2</td> <td>F3</td> <td>F4</td> </tr> </table>	[Road]				F1	Define road path	(1)		F2	Road Stakeout	(2)		F3	Result. Setting out	(3)		F4	Transfer	(4)		F1	F2	F3	F4
[Road]																										
F1	Define road path	(1)																								
F2	Road Stakeout	(2)																								
F3	Result. Setting out	(3)																								
F4	Transfer	(4)																								
F1	F2	F3	F4																							
	[F1]	<table border="1"> <tr> <td colspan="4">[Horizontal alignment]</td> </tr> </table>	[Horizontal alignment]																							
[Horizontal alignment]																										



<p>○3 There are 2 methods for defining a road. Press F1 <b>Elements Method</b> for first method.</p>		<table border="1"> <tr> <td colspan="4">F1 Element Method (1)</td> </tr> <tr> <td colspan="4">F2 Intersection Method (2)</td> </tr> <tr> <td>F1</td> <td>F2</td> <td>F3</td> <td>F4</td> </tr> <tr> <td colspan="4"> </td> </tr> </table>	F1 Element Method (1)				F2 Intersection Method (2)				F1	F2	F3	F4																								
F1 Element Method (1)																																						
F2 Intersection Method (2)																																						
F1	F2	F3	F4																																			
<p>○4 Then input the data by clicking F1 <b>Add</b> button. There are three types of the elements<sup>1</sup>.          [STR]: Straight line, radius should keep 0.000, which means infinite.          [ARC]: Curve.          [TRANS]: Spiral.          [Radius] The Radius is the starting one. Positive value means the spiral direction is right while the negative value means the direction of the spiral is left.</p>	<p>[F1]</p>	<table border="1"> <tr> <td colspan="4">[Element Method]</td> </tr> <tr> <td colspan="3">Chainage :</td> <td>↕</td> </tr> <tr> <td>Type :</td> <td colspan="3">Radius</td> </tr> <tr> <td>:</td> <td colspan="3"> </td> </tr> <tr> <td>N :</td> <td colspan="3"> </td> </tr> <tr> <td>E :</td> <td colspan="3">Length</td> </tr> <tr> <td>:</td> <td colspan="3"> </td> </tr> <tr> <td>Add</td> <td> </td> <td>View</td> <td> </td> </tr> <tr> <td colspan="4"> </td> </tr> </table>	[Element Method]				Chainage :			↕	Type :	Radius			:				N :				E :	Length			:				Add		View					
[Element Method]																																						
Chainage :			↕																																			
Type :	Radius																																					
:																																						
N :																																						
E :	Length																																					
:																																						
Add		View																																				
<p>○5 Another method to define the road path is Intersection Method. Go back to the previous menu and press F2 Intersection Method.</p>	<p>[F2]</p>	<table border="1"> <tr> <td colspan="4">[Horizontal alignment]</td> </tr> <tr> <td colspan="4">F1 Element Method (1)</td> </tr> <tr> <td colspan="4">F2 Intersection Method (2)</td> </tr> <tr> <td>F1</td> <td>F2</td> <td>F3</td> <td>F4</td> </tr> <tr> <td colspan="4"> </td> </tr> </table>	[Horizontal alignment]				F1 Element Method (1)				F2 Intersection Method (2)				F1	F2	F3	F4																				
[Horizontal alignment]																																						
F1 Element Method (1)																																						
F2 Intersection Method (2)																																						
F1	F2	F3	F4																																			





Clicking F1 <b>Add</b> to add the necessary info <sup>'''2</sup> .	F1	[PT]
		Chainage : <input type="text"/>
		N : <input type="text"/>
		E : <input type="text"/>
		Radius : <input type="text"/>
		slownesscu <input type="text"/>
		slownesscu <input type="text"/>
		<input type="button" value="Add"/> <input type="button" value="View"/>
<sup>'''1</sup> : The type combo must be Line-Spiral-Curve-Spiral-Line, Line-Spiral-Spiral-Line, Line-Curve-Line, Spiral-Curve-Spiral.		
<sup>'''2</sup> : Maximum 20 sets of data can be used in Intersection Method.		

## 12.2 Road Stakeout

After the road had been designed and had been implemented into the program, user can start to do road stakeout.

Steps	Key	Display
O1 In Road program, click F2 <b>Road Stakeout</b> to enter the function.	[F2]	[Road]
		F1 Define road path (1) F2 Road Stakeout (2) F3 Result. Setting out (3) F4 Transfer (4)
		<input type="button" value="F1"/> <input type="button" value="F2"/> <input type="button" value="F3"/> <input type="button" value="F4"/>
O2 Pressing F1 <b>Sidestake Stakout</b> to go for sidestake stakeout interface. Input the chainage and the coordinates of the points that should be stakeout will be loaded and you will start the staking job.	[F1]	
		[ Sides take stakeout] <input type="text"/> 1/3 Chaina ge : 0.0 00 m T.H. : 0.0 00 m

[T.H]:Target height  
[Increment]: Interval between to stakes.  
[Offset] : the offset to the center stake, left is negative while right is positive.

Azimut h :	0.0 00		
Back :	0.0 00 m		
Offset lef:	0.0 00 m	 	
LA			
<b>Meas.</b>	REC	EDM	<b>Coord.</b>

### 12.3 Result.Setting out

After the staking out, the result can be checked.

Steps	Key	Display
① Click F3 <b>Result.Setting out</b> for the result checking.	[F3]	<pre> [Road] F1 Define road path (1) F2 Road Stakeout (2) F3 Result. Setting out (3) F4 Transfer (4)           </pre>
② All the result with corresponding result can be viewed here.	[F1]	<pre> [Result.Sidestake stakeout] Chainage : 0.000 m Offset : 1.300 m E : 0.000 m N : 0.000 m Z : 0.000 m           </pre>

### 12.4 Transfer

User can import the predefined road data for staking out while he can also export the result. Either by serial com port or by USB disk. By clicking F4 in the home button then there will come for the import and export.

Steps	Key	Display
-------	-----	---------

<p>O1 Pressing key [F4] enter Data transfer function</p>	<p>[F4]</p>	<table border="1"> <tr> <td colspan="4">[Road]</td> </tr> <tr> <td>F1</td> <td>Define road path</td> <td>(1)</td> <td></td> </tr> <tr> <td>F2</td> <td>Road Stakeout</td> <td>(2)</td> <td>F3</td> </tr> <tr> <td></td> <td>Result. Setting out</td> <td>(3)</td> <td></td> </tr> <tr> <td>F4</td> <td>Transfer</td> <td>(4)</td> <td></td> </tr> <tr> <td>F1</td> <td>F2</td> <td>F3</td> <td>F4</td> </tr> </table>	[Road]				F1	Define road path	(1)		F2	Road Stakeout	(2)	F3		Result. Setting out	(3)		F4	Transfer	(4)		F1	F2	F3	F4
[Road]																										
F1	Define road path	(1)																								
F2	Road Stakeout	(2)	F3																							
	Result. Setting out	(3)																								
F4	Transfer	(4)																								
F1	F2	F3	F4																							
<p>[PHI]:Means the intersection data. [Sec]:refer to the element method [TXT]: is for the stake data. All data mentioned above can be created by Hi-Survey.</p>	<p>[F3]</p>	<table border="1"> <tr> <td colspan="4">[ Transfer]</td> </tr> <tr> <td>Transfer :</td> <td>Import</td> <td></td> <td>↔</td> </tr> <tr> <td>Mode :</td> <td>RS232C</td> <td></td> <td>↔</td> </tr> <tr> <td>Source :</td> <td>PHI</td> <td></td> <td>↔</td> </tr> <tr> <td>Back</td> <td>Sourc</td> <td>e</td> <td>OK</td> </tr> </table>	[ Transfer]				Transfer :	Import		↔	Mode :	RS232C		↔	Source :	PHI		↔	Back	Sourc	e	OK				
[ Transfer]																										
Transfer :	Import		↔																							
Mode :	RS232C		↔																							
Source :	PHI		↔																							
Back	Sourc	e	OK																							

### 13. Stakeout Reference Element

Stakeout Reference Element is used for making Reference Element stakeout and check easier, such as building, road cross section, or simple excavation. User can define a Reference Line/ARC, according to measuring result, to calculate out the deviated difference& elevation difference between measuring point and reference line/arc. Reference element function include:

- ◇ RefLine
- ◇ RefArc
- ◇ RefSurface

#### 13.1 RefLine

User need to define a reference line through a known base line. The reference line can be shifted in longitudinal, horizontal, vertical direction, or rotate around the first base point as needed. The line after shift is as reference line, all observed data refer reference line. User can choose the first point, second point or mean point in refline direction as referred elevation point.

Refline schematic diagram:

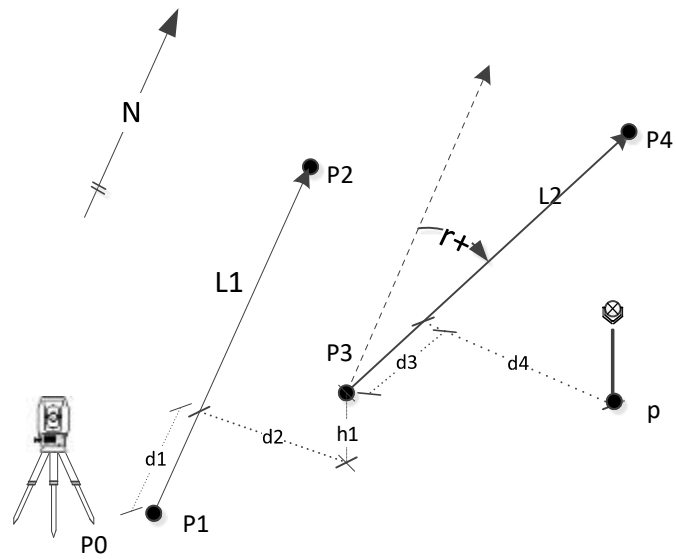

**Known**

L1 Baseline

P1 First point

P2 Second point

d1 Offset

r+ Rotate

L2 Reference Line

P3 First reference point

P4 Second reference point

d2 Line

P0 STA

**Unknown** p

Measure point d3  $\Delta$

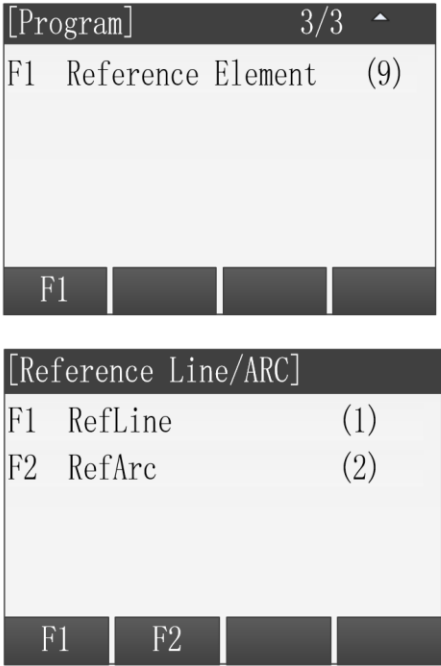
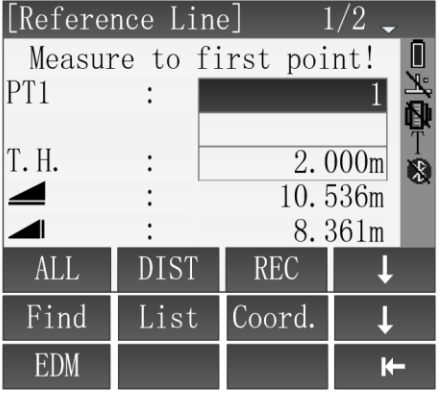

Length d4  $\Delta$  trav.

● Reference Line

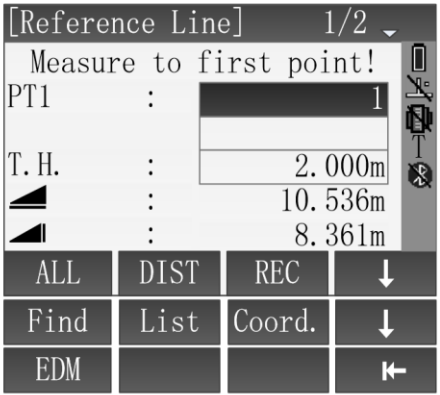
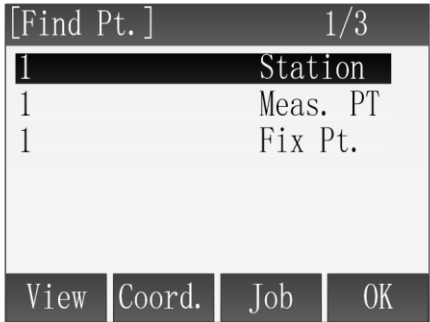
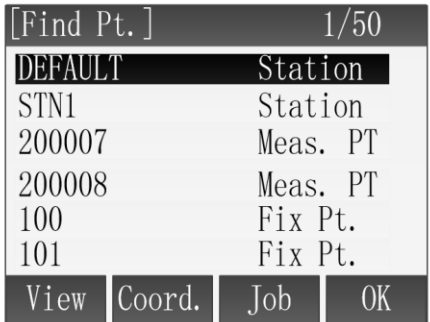
Steps	Key	Display
<p>① Press [F1] or numeric key [9] in main menu, then set Job, B.S and enter [Reference Line/ARC] menu([F4]), press [F1] or numeric key [1] to enter RefLine function.</p>	<p>[F1] or [9]  [F1] or [1]</p>	 <p>[Program] 3/3 ^ F1 Reference Element (9) F1         [Reference Line/ARC] F1 RefLine (1) F2 RefArc (2) F1   F2      </p>
<p>② There're several methods to obtain the first point for baseline definition</p> <p>A: Enter point name, then press [F1](ALL) to define first point.</p>	<p>Input point name + [F1]</p>	<p>A: Get the target point by measure.</p>  <p>[Reference Line] 1/2 v Measure to first point! PT1 : [1] T. H. : 2.000m ▲ : 10.536m ▲ : 8.361m ALL   DIST   REC   ↓ Find   List   Coord.   ↓ EDM       ←</p>

<p>B: Input point name, Press [F2](DIST) + [F3](REC) to save target point, the saved result will be directly put into calculation.</p>	<p>[F2] + [F3]</p>	<p>B: Get the target point by DIST+REC.</p> 
<p>C: Input point name, press [F4](↓) to shift to subscript function, then press [F1](Find) to check if this point exists, if not exist, then should firstly input or</p>	<p>Input point name + [F4] + [F1] + [F4]</p>	<p>C: Input the name of the point and find whether it is in memory.</p> 
<p>D: Press [F2](List) , in [Find Pt.] dialog, search the known points in job through [▲]\[▼] and press [F4](OK) to select.</p>	<p>[F2] + [F4]</p>	<p>D: Select the point by list in the instrument.</p> 
<p>E: Press [F3](Coord.), input point name, coordinate data and press [F4](OK), it will indicate cover if the point name is repeated.</p>	<p>[F3] + Input point name coordinate+ [F4]</p>	<p>E: Input the point through keyboard.</p>

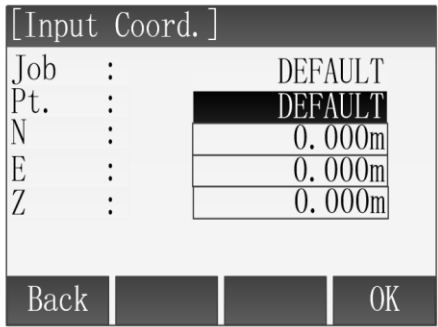
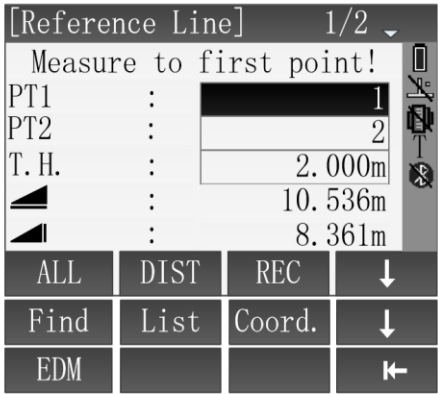
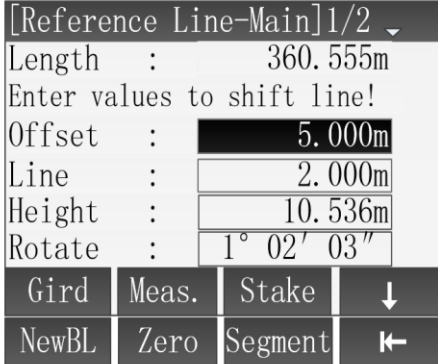
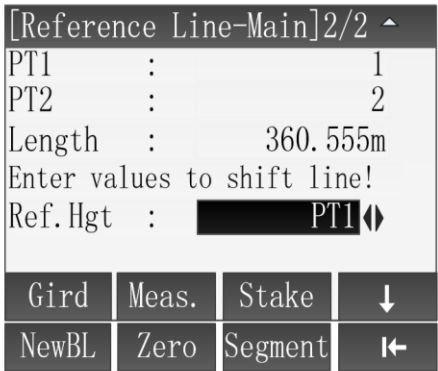
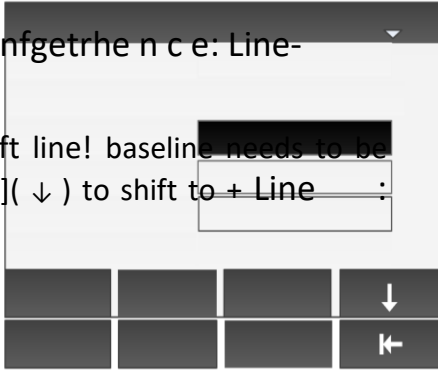

		
<p>③ After defining first point of baseline, enter into interface of second point definition, the way is same as with first point.</p>	<p>[F1] or [F2]+[F3] or [F4]+[F1] or [F4]+[F2] or [F4]+[F3]</p>	
<p>④ After baseline definition, enter [Reference Line-Main] interface, select settings through [▲]\[▼], input translation and rotation parameters.</p> <p>Press [F4]( ↓ ) to enter [Reference Line-Main] press [◀]\[▶] to choose Ref.Hgt, after set up.※<sup>1</sup></p>	<p>[▲]\[▼] + Input parameter [F4] + [◀]\[▶]</p>	 
<p>⑤ In the interface of [Reference Line-Main], if Enter values to shift line! baseline needs to be redefined, [F4] Offset : 5.000m press [F4]( ↓ ) to shift to + Line : 2.000m</p>	<p>[ L Re en f g e t r h e n c e : L i n e - M a 3 i 6 n 0 ] . 1 5 / 5 2 5 m</p>	
<p>156</p>		

Height : 10.536m

subscript function and press [F1] [F1] Rotate : 1°02'03"

(NewBL) to redefine new Gird Meas. Stake baseline. NewBL Zero Segment

⑥ In the interface of [ P R T e 1 f e r e n c e : Line-Main]2/21  
 [Reference Line-Main] , input PT2 : 2 translation parameters, if you [F4] Length : 360.555m  
 need to clear, press [F4] (↓) to + Enter values to shift line!  
 Ref.Hgt : PT1

shift subscript function, press [F2]  
 [F2] (Zero) to recover input Gird Meas. Stake parameters to zero. NewBL Zero Segment

'''1 Ref.Hgt options :

- PT1 : The elevation value of defined first point
- PT2 : The elevation value of defined second point
- Equal : Average value of defined two endpoints' elevation
- None : Not perform elevation difference calculation

''' In above operation, press [ESC] to return to previous menu

Steps	Key	Display
① In the interface of [Reference Line-Main], press [F1] (Gird) to enter the [Grid Definition] .	[F1]	<div style="border: 1px solid black; padding: 5px;">           [ Reference Line- Main]1/2            Length : 360.555m            Enter values to shift line Offset :            Line : 2.000m            Height : 10.536m            Rotate : <span style="border: 1px solid black; padding: 2px;">1°02 03</span>            Gird <span style="border: 1px solid black; padding: 2px;">Meas.</span> Stake         </div>
② In the [Grid Definition] interface, use [▲] \ [▼] to select input box, use keyboard to enter + start chainage of gird and	[▲] \ [▼]	<div style="border: 1px solid black; padding: 5px;">           [ G r i d D e f i n i t i o n ]            Enter start c h a i n a g e o f g r i d !            1. 147m         </div>

● **Stakeout Grid**

increment grid points, then press [F4](OK) to next step.	Input parameters  + [F4]	<table border="1"> <tr> <td colspan="2">Start Chain:</td> <td>rid poin ts</td> </tr> <tr> <td>Inc rement</td> <td></td> <td>2. 258m</td> </tr> <tr> <td>g Increm ent</td> <td></td> <td>3. 369m</td> </tr> <tr> <td>:</td> <td></td> <td></td> </tr> <tr> <td colspan="3">Transv erse :</td> </tr> <tr> <td>Back</td> <td></td> <td>OK</td> </tr> </table>	Start Chain:		rid poin ts	Inc rement		2. 258m	g Increm ent		3. 369m	:			Transv erse :			Back		OK
Start Chain:		rid poin ts																		
Inc rement		2. 258m																		
g Increm ent		3. 369m																		
:																				
Transv erse :																				
Back		OK																		

<p>③ In [Stakeout Grid] interface, use [◀] [▶] to select the offset, chainage, then press [F1](ALL) or [F2]+[F3] (DIST+REC) to save this measuring point data.</p>	<p>[◀] [▶] + [F1] or [F2]+[F3]</p>	
--	--	--

''' In above operations, press [ESC] to return to previous menu.

● **Measure Line&Offset**

	Steps Key	Display
<p>In interface of [Reference Line-Main] , press [F2] (Meas.) to enter [Measure Line&amp;Offset] interface. Rotate : 1°02'03"</p>	<p>Enter values to shift line! Offset : 5.000m [F2] Line : 2.000m</p>	
<p>Gird Meas. Stake  O2 There are many methods to</p>		

---

[ Measure Line&Offset]

obtain points for calculating Pt. : 4 Input point T.H. : 2.000m  
Line&Offset

name  Length : 31..316497m

m  $\uparrow$  A: Input the name of point,  Trav. :

+ press [F1](ALL) to measure

\_ : 1.256m

[F1]

current point, calculate and

display the offset to reline , ALL DIST REC then save this point data.

B: Input point name, press [F2]  
(DIST) to measure target point, [F2]  
calculate and display this point's +  
offset to reline, then press [F3]  
[F3](REC) to save this point data.

B: Get the target point  
by DIST+REC.

C: Input the name of known point and press [F4](↓) to shift	Input point	C: Input the name of the point and find whether it is in memory.
to subscript function, then press [F3](Find) to find whether the point is in memory, if exist, then press [F4](OK) to be selected for calculating; if not exist, then need to input or measure the point.	name + [F4] + [F1] + [F4]	
D: Press [F2] (List) in [Find Pt.] screen, use the key [▲]\[▼] to select a known point in the point list for traverse calculation, then press [F4](OK) to be selected.	[F2] + [F4]	<p>D: Select the point by list in the instrument.</p>
E: Press [F3](Coord.) to input a known point that not exist in memory.	[F3] + Input point name coordinate+ [F4]	<p>E: Input the point through keyboard.</p>

※ In above operation, press [ESC] to return to previous menu.

● **Orthogonal stakeout** Steps Key Display

[ R eference Line-Main]1/2  
 Length : 360.555m

○1 In [Reference Line-Main] E Onftfesre tv a l ue:s to shift 5! .i0n0e0!m screen,  
 press [F3](Stake) enter [F1] Line : 2.000m  
 Height :10.536m [Orthogonal  
 stakeout] to input Rotate : 1°02'03"  
 stakeout values. Gird Meas. Stake  
 NewBL Zero Segment

② In interface of [▲][▼] [E On rttehro goorntahl. SSttaakkeeo  
 uvta] lues!  
 +  
 [Orthogonal Stakeout] use Input Pt. : 360.555m [▲][▼] to select input box,  
 use T.H. : 5.000m  
 parameter EndW.OS. : 2.000m  
 keyboard to set every offset  
 s Transverse: 10.536m  
 parameters, then press [F4](OK) + Z : 1°02'03" to enter orthogonal  
 stakeout. [F4] Back Reset OK

[ O rthog. Stakeout] 1/2  
 ③ In [Orthg. Stakeout] Pt. : 3  
 T.H. : 2.000m  
 interface, measure and save  
 [F1] T  
 current measuring point through or Hz -1°02'03" [F1](ALL) or  
 [F2]+[F3](DIST+REC), -146.573m  
 [F2]+[F3] : -15.842m  
 and it will return to [Orthogonal  
 ALL DIST REC  
 Stakeout] screen.  
 NEXT PT EDM Back

''' In above operation, press [ESC] to return to previous menu.

● Segment stakeout

Steps	Key	Display
-------	-----	---------

<p>○1 In [Reference Line-Main] + screen, press [F4](↓) and Press [F3] to enter [Segment Definition] interface</p>	<p>[F4] [F1]</p>	<p>[ R eference Line-Main]1/2 Length : 360.555m Enter values to shift line! Offset : 5.000m Line : 2.000m Height : 10.536m Rotate : 1°02'03"</p> <table border="1" data-bbox="853 577 1332 694"> <tr> <td>Gird</td> <td>Meas.</td> <td>Stake</td> <td>▼</td> </tr> <tr> <td>NewBL</td> <td>Zero</td> <td>Segment</td> <td>◀</td> </tr> </table>	Gird	Meas.	Stake	▼	NewBL	Zero	Segment	◀
Gird	Meas.	Stake	▼							
NewBL	Zero	Segment	◀							

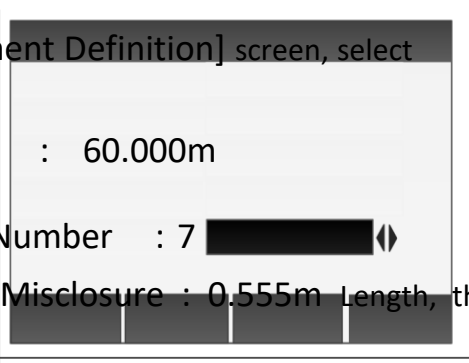
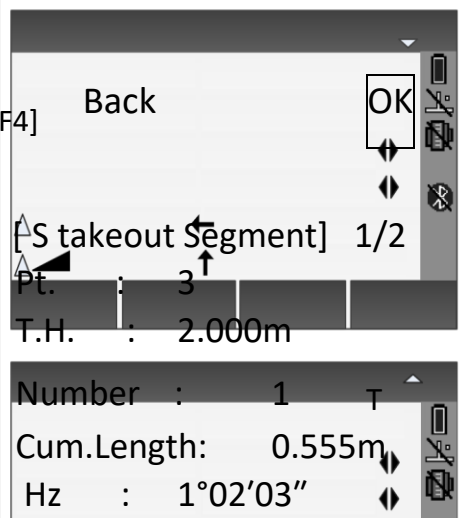
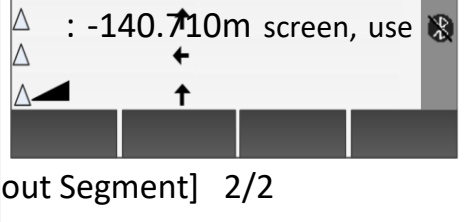

<p>② In [Segment Definition] ▲▼ [ S egment Definition] screen, select input box [ ]\ [ ] Line Length: 360.555m through [ ▲]\ [ ▼], use keyboard to set the Segment parameters Segment No. and Segment :</p>	<p>▲▼ [ S egment Definition] screen, select input box [ ]\ [ ] Line Length: 360.555m through [ ▲]\ [ ▼], use keyboard to set the Segment parameters Segment No. and Segment :</p>	
<p>others, then press [F4](OK) to enter segment stakeout.***</p>	<p>1 [F4]</p>	
<p>③ In [Stakeout Segment] [◀]\ [▶] — [◀]\ [▶] to select ALL DIST REC EDM segment No., then save current point data through</p>	<p>[F1] [ S takeout Segment] 2/2</p>	

or Pt. : 3

[F1](ALL)or Cum.Length:0.555m

[F2]+[F3] (DIST+REC) Number : 1

Length 130.644m<sup>T</sup>  
 Trav. -52.216m  
 - -8.188m  
 ALL DIST REC EDM

\*\*\*1 Segment options:

Start : Misclosure at the start point

EndPt : Misclosure at the end point

Equal : Divide Reference Line equally into several pieces "" In above operation, press [ESC] to return to previous menu.

### 13.2 RefArc

RefArc can be defined through "Centre, Start Point" or "Start&End Pt, Angle", and you can calculate Line&Offset of point to refarc. The application program allow user define a refarc and finish below task about refarc:

- Measure Line&Offset

RefArc schematic diagram:

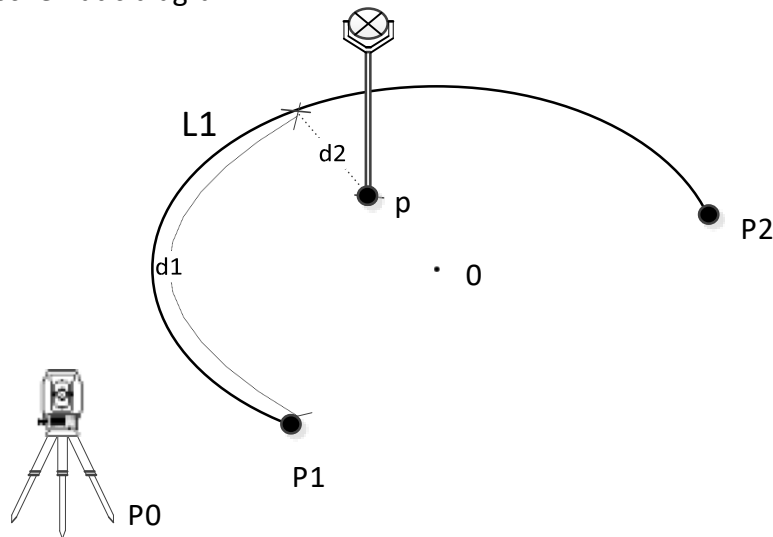

#### Known

L1 RefArc  
O Centre  
P0 STA

P1 Start PT  
P2 End PT

**Unknown** p

Measure point d1

△Line d2 △Offset

#### ● Centre, Start PT

Steps	Key	Display
-------	-----	---------

<p>○1 In [Program] main menu 3/3 page, press [F1] or numeric [9], set job, B.S. and enter [Reference Line/ARC] menu, then press [F2] or numeric [2] to enter RefArc function.</p>	<p>[F1] or [9]</p> <p>[F2] or [2]</p>	<table border="1"> <tr> <td colspan="4">[Program] 3/3 ^</td> </tr> <tr> <td colspan="4">F1 Reference Element (9)</td> </tr> <tr> <td>F1</td> <td></td> <td></td> <td></td> </tr> <tr> <td colspan="4">[Reference Line/ARC]</td> </tr> <tr> <td colspan="4">F1 RefLine (1)</td> </tr> <tr> <td colspan="4">F2 RefArc (2)</td> </tr> <tr> <td>F1</td> <td>F2</td> <td></td> <td></td> </tr> </table>	[Program] 3/3 ^				F1 Reference Element (9)				F1				[Reference Line/ARC]				F1 RefLine (1)				F2 RefArc (2)				F1	F2		
[Program] 3/3 ^																														
F1 Reference Element (9)																														
F1																														
[Reference Line/ARC]																														
F1 RefLine (1)																														
F2 RefArc (2)																														
F1	F2																													

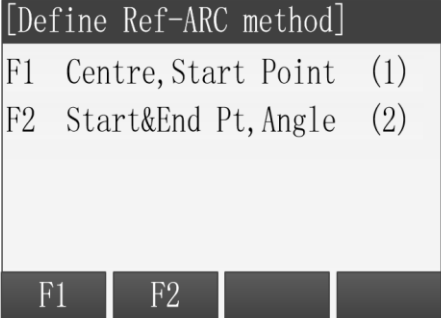
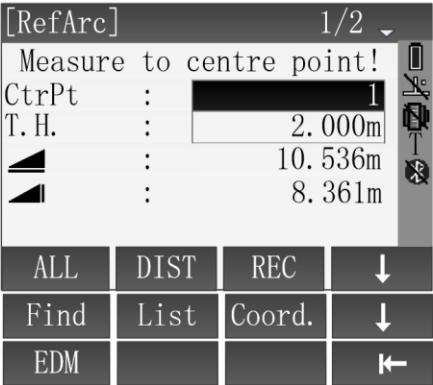
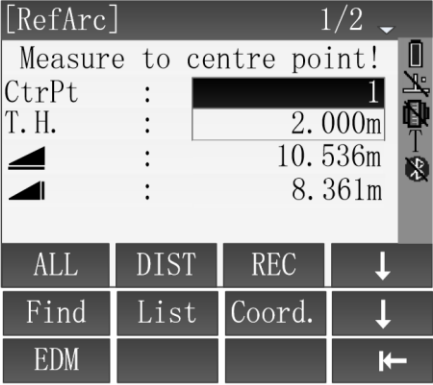
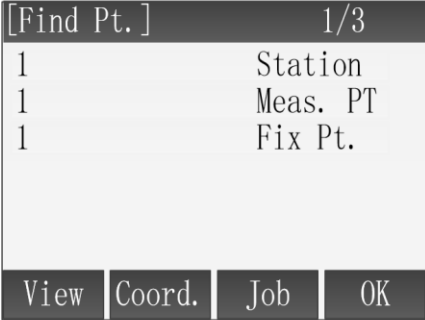
<p>② In [Define Ref-ARC method] screen, then press [F1] or numeric key [1], enter [Centre, Start Point] method, measure Centre point to define arc.</p>	<p>[F1] or [1]</p>	
<p>③ There are several methods to obtain CtrPt which is used for RefArc definition</p> <p>A: Enter point name, then press [F1](ALL) to define the CtrPt.</p>	<p>Input point name + [F1]</p>	<p>A: Get the target point by measure.</p> 
<p>B: Input point name, Press [F2](DIST) + [F3](REC) to save the centre point, the saved result will be directly put into calculation.</p>	<p>[F2] + [F3]</p>	<p>B: Get the target point by DIST+REC.</p> 
<p>C: Input point name, press [F4](↓) to shift to subscript function, press [F1](Find) to check if this point exists, if not exist, then should firstly input or measuring this point's coordinate.</p>	<p>Input point name + [F4] + [F1] + [F4]</p>	<p>C: Input the name of the point and find whether it is in memory.</p> 

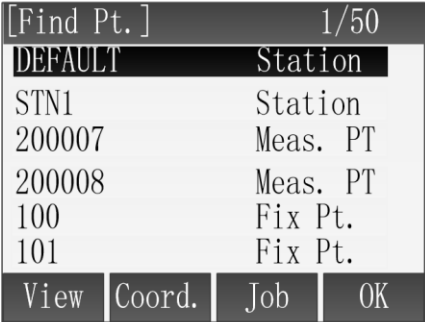
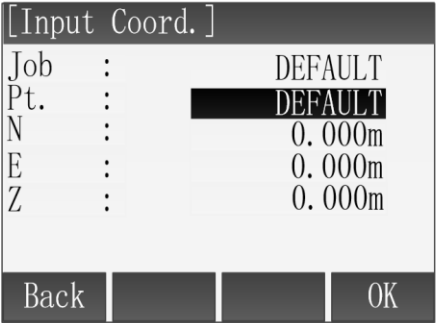
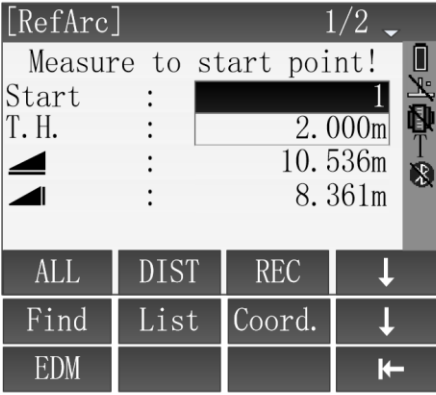
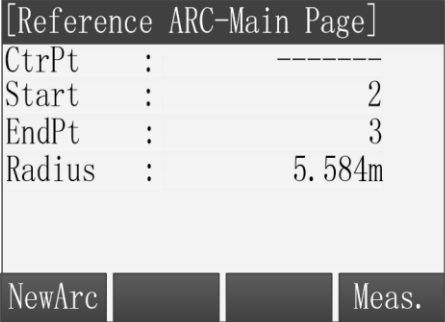
<p>D: Press [F2](List) , in [Find Pt.] dialog, search the known points in job through [▲][▼] and press [F4](OK) to select.</p>	<p>[F2] + [F4]</p>	<p>D: Select the point by list in the instrument.</p> 
<p>E: Press [F3] (Coord.), input point name, coordinate's data, it will indicate recover if point name is repeated, then press [F4](OK) to save the point.</p>	<p>[F3] + Input point name coordinate+ [F4]</p>	<p>E: Input the point through keyboard.</p> 
<p>④ After measuring centre point, you can measure the start point, the definition is same as centre point. ※<sup>1</sup></p>	<p>[F1] or [F2]+[F3] or [F4]+[F1] or [F4]+[F2] or [F4]+[F3]</p>	
<p>⑤ After definition of RefArc, enter interface of [Reference ARC-Main Page];</p> <p>Press [F4](Meas.) to enter [Measure Line&amp;Offset] interface;</p>	<p>[F4]</p>	

<p>If it needs to define a new RefArc , press [F1](NewArc) to define.</p>	<p>[F1]</p>	
---	-------------	--

※<sup>1</sup> When the centre and start point coincide, the system error reporting "invalid target data, please input again, select "yes" or press [ESC], return to the measurement center interface, and restart the definition of arc. "" In above operation, press [ESC] to return to previous menu.

● **Start&End Pt, Angle**

Steps	Key	Display
-------	-----	---------

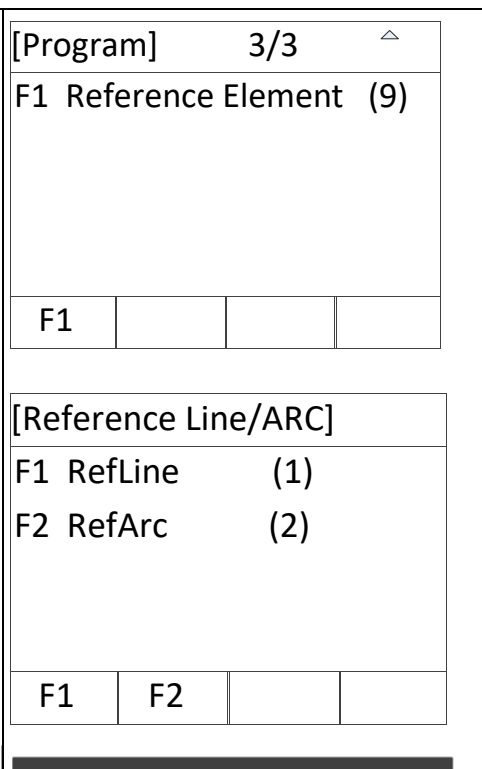
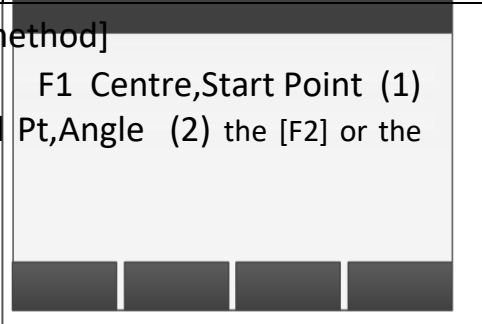
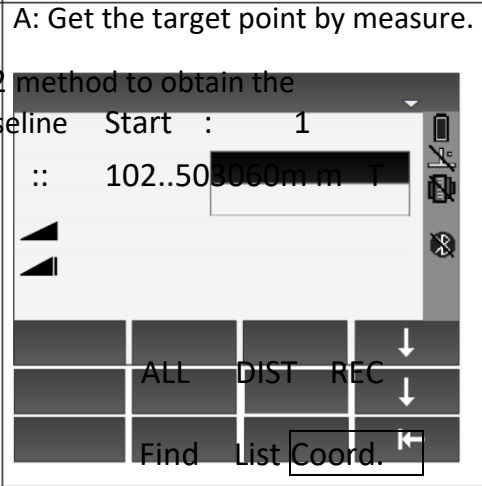
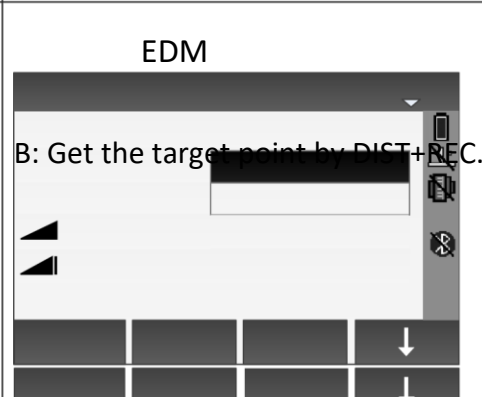
<p>○1 Press the [F1] or the numeric key [9] in the 3/3 page of the main menu, set the job, B.S and enter [Reference Line/ARC] menu, then press the [F2] or the numeric key [2] to enter the definition of RefArc.</p>	<p>[F1] or [9]</p> <p>[F2] or [2]</p>	
<p>○2 In [Define Ref-ARC method] screen, press [F2] F2 Start&amp;End Pt,Angle the [F2] or the numeric or key [2] to choose the [2] [Start&amp;End Pt, Angle ], and measure start point.</p>	<p>F1 F2</p>	
<p>③ There are several [ R efArc] 1/2 definition Input point name T_._H_ . : 8.361m A: Enter point name, then press [F1](ALL) to define start point.</p>	<p>[F1]</p>	<p>A: Get the target point by measure.</p> 
<p>170</p>		<p>EDM</p> <p>B: Get the target point by DIST+REC.</p> 

---

---

B: Input point name, Measure to start point! press [ R efArc] 1/2  
Start : 1 [F2](DIST) +

[F3](REC) to save target [F2] T.\_H. :: 102..503060m m T  
+ point , the saved result : 8.361m  
[F3]

will be directly put into

calculation.

ALL DIST REC

Find List

EDM

C: Input point name, C: Input the name of the point and

Input point name find whether it is in memory.  
press [F4](↓) to shift to

+ [ F ind Pt.] 1/3  
subscript function, press [F4] 1 Station

[F1](Find) to check if this +  
point exists, if not exist, [F1]  
then should firstly input +

or measure this point's [F4]

coordinate. View  Job OK

D: Press [F2](List) , in [F2] D: Select the point by list in the [Find Pt.] screen, search +  
instrument.

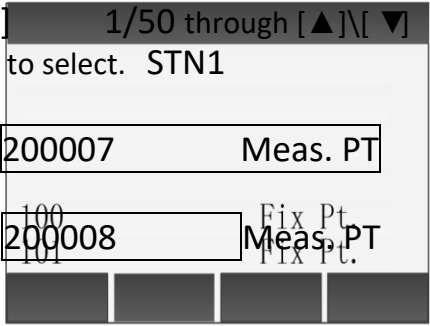
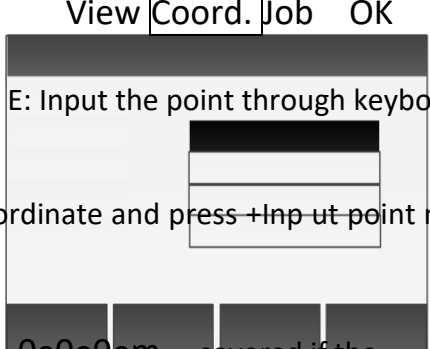
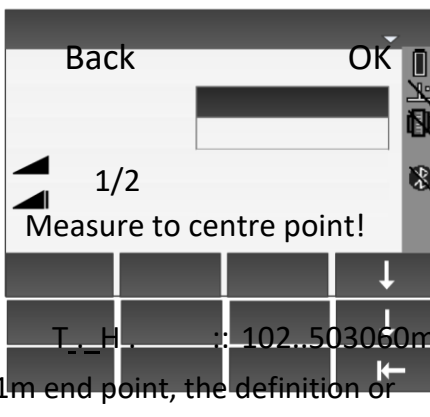
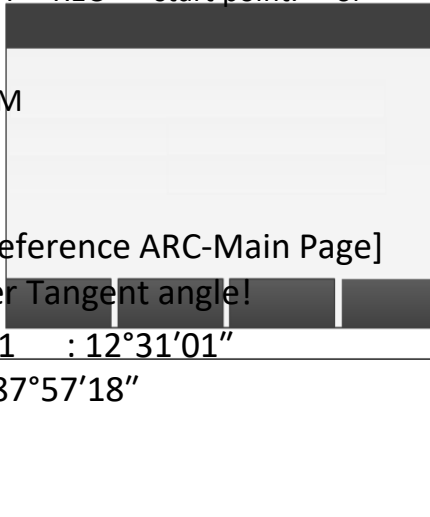

<p>the known points in job [F4] [ F ind Pt.] and DEFAULT Station press [F4](OK) Station</p>		
<p>E: Press [F3](Coord.), [ I nput Coord.] input point name, [F3] Job : DEFAULT coordinate and press +Inp ut point name</p>		
<p>[F4](OK), it will be coordinate+ Ez : 00.00000m covered if the point [F4] name is repeated.</p>	<p>[F1] [ R efArc]</p> <p>④ After definition of or CtrPt : 1 the start point, enter the [orF2]+[F 3] interface of measure to [F4]+[F1] : 8.361m end point, the definition of</p>	
<p>of end point is same as [F4]+[F2] ALL DIST REC start point. or Find List Coord.</p> <p>⑤ After completing the definition of the start&amp;end point, input Enter Tangent angle! the AZ1(start point), Enter angle AZ1 : 12°31'01" + AZ2 : 87°57'18" AZ2(end point) tangent angle respectively, then</p>	<p>[F4]+[F3] EDM</p> <p>[Reference ARC-Main Page]</p>	

press [F4](OK) to next step."<sup>1</sup>

Back

OK

⑥ Reference arc was defined, enter the [Reference ARC-Main Page] interface;

Press [F4] (DIST) into the [Measure Line&Offset] function;



If it needs to define a new RefArc , press [F1] (NewArc) to define.

The screenshot displays three sequential screens from the instrument's menu system:

- [Reference ARC-Main Page]:** Shows parameters for a reference arc: CtrPt (-----), Start (2), EndPt (3), and Radius (5.584m). Navigation buttons include NewArc and Meas.
- [Measure Line&offset]:** Shows measurement results: Pt. (4), T. H. (2.000m), ΔLine (130.644m), ΔOffset (-52.216m), and Δ (8.188m). Navigation buttons include ALL, DIST, REC, and a downward arrow.
- [RefArc]:** Shows parameters for a new reference arc: Measure to centre point!, CtrPt (1), T. H. (2.000m), and two other values (10.536m and 8.361m). Navigation buttons include ALL, DIST, REC, Find, List, Coord., EDM, and a leftward arrow.

※<sup>1</sup> AZ1 and AZ2 are start point, end point tangent azimuth respectively . If the input data is not in conformity with the requirements, the instrument will report "invalid target data, please input again", you can select "yes" or press the [ESC] to return to the interface of starting point measurement, start to define arc. "" In above operation, press [ESC] to return to previous menu.

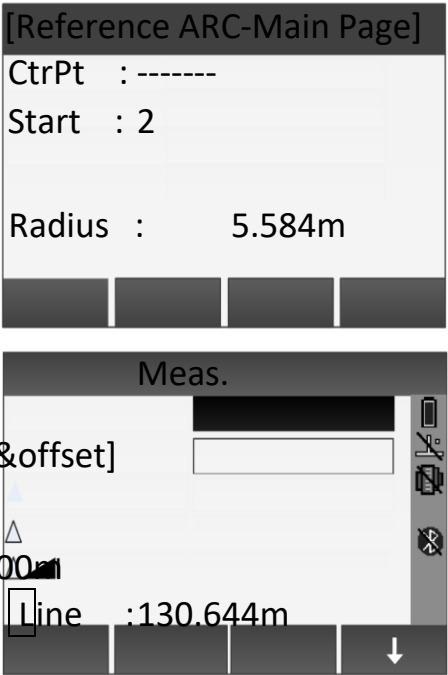
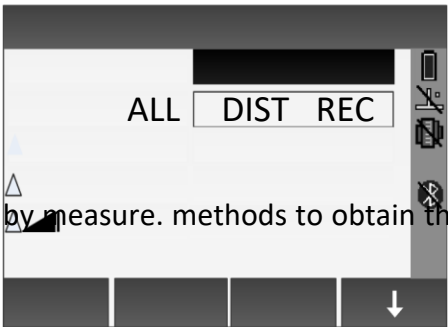
● Measure Line&Offset

Steps	Key	Display
<p>○1 Using method of the "Centre, Start Point" or "Start&amp;End Pt, Angle" defines the reference arc, entering the [Reference Pt. ARC-Main Page], and press [F4] (Meas.) to</p>	<p>EndPt : 3</p> <p><b>NewArc</b></p> <p>[F4]</p> <p>[ Measure Line&amp;offset]</p> <p>: 4</p> <p>T.H. : 2.000m</p> <p>-52.216m<sup>T</sup></p>	
<p>Measure Line&amp;Offset</p> <p>② There are several A: Get the target point by measure. methods to obtain the [ Measure Line&amp;offset]</p> <p>Pt which is used for</p>	<p>Offset :</p> <p>:-8.188m</p> <p>Pt. : 4</p>	
<p>Measure Line&amp;Offset</p> <p>Offset : -52.216m<sup>T</sup></p> <p>A: Enter point name,</p>	<p>Input point name T.H. : 2.000m</p> <p>+ <b>Line</b> : 130.644m</p> <p>[F1]</p> <p>: -8.188m then press [F1](ALL) to</p>	

---

define the Pt.      ALL    DIST    REC

B:    Get    the    target    point    by  
DIST+REC.

B: Input point name,

[ Press    [F2](DIST)    +

P M t e . a s u r e    L i : n e & o f f s e t ]    4

[F2]

[F3](REC) to save the    T.H.    :    2.000m

+

Pt, the saved result will    [L] i n e    :    130.644m    T

[F3]

be directly put into    O f f s e t    :    -52.216m

:    -8.188m

calculation.

ALL    DIST    REC

C: Input point name, Input point name

+

C: Input the name of the point and

press [F4](↓) to shift to

[F4]

find whether it is in memory.

subscript    function, +

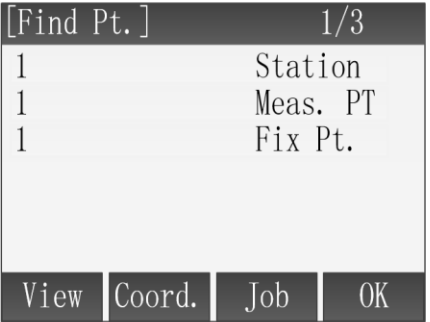
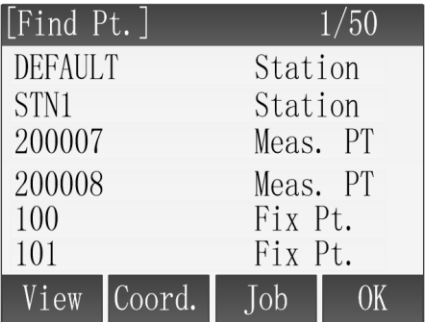
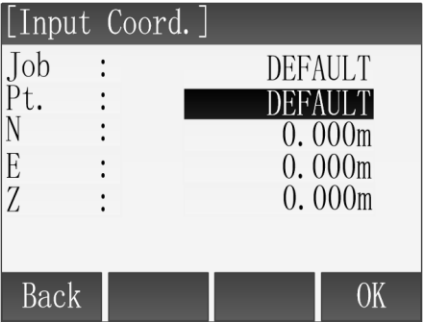
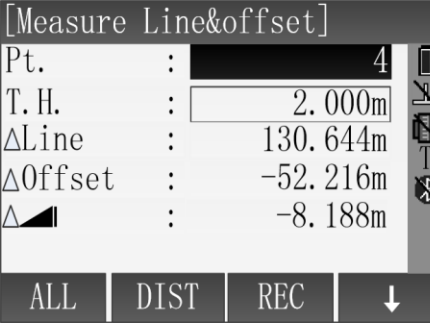
<p>press [F1](Find) to check whether this point was existed, if not exist, then should firstly input or measuring this point's coordinate.</p>	<p>[F1] + [F4]</p>	
<p>D: Press [F2](List) , in [Find Pt.] screen, search the known points in job through [▲][▼] and press [F4](OK) to select.</p>	<p>[F2] + [F4]</p>	<p>D: Select the point by list in the instrument.</p> 
<p>E: Press [F3](Coord.), Input point name, coordinate's data, it will indicate recover if point name is repeated, then press [F4](OK) to save the point.</p>	<p>[F3] + Input point name coordinate + [F4]</p>	<p>E: Input the point through keyboard.</p> 
<p>③ After measuring points in different ways, we can see the result of the high deviation, <math>\Delta</math>Line and <math>\Delta</math>Offset.※<sup>1</sup></p>		

※<sup>1</sup> Result of Line&Offset:

$\Delta$ Line: Measuring point relative to the start point of arc , if it is beyond the reference arc , $\Delta$ Line will be negative, and on the contrary is positive;

$\Delta$ Offset: the offset of the measuring point with respect to the arc in the direction of the radius. If the measuring point is in the circle, the  $\Delta$ Offset will be positive, and on the contrary is negative.

$\Delta$ ▲: the elevation difference between measuring point and starting point;If it is higher than start point, it will be positive, and on the contrary is negative.

''' In above operation, press [ESC] to return to previous menu.

### 13.3 RefSurface

Reference Surface is also known as Reference Plane. It is a function that can be used to measure points relative to a reference plane. It can be used to:

- **Measuring a point to calculate and store the perpendicular offset to the plane**
- **Calculating the perpendicular distance form the intersection point to the local X and Z axis. The intersection point is the footprint point of the perpendicular vector from the measured point through the defined plane.**
- **Viewing, storing and staking out the coordinates of the intersection point.** A reference plane is created by measuring three points on a plane. These three points define a local coordinate system:
  - **The first point is the origin of a local coordinate system.**
  - **The second point defines the direction of the local Z-axis.** □ **The third point defines the plane.**

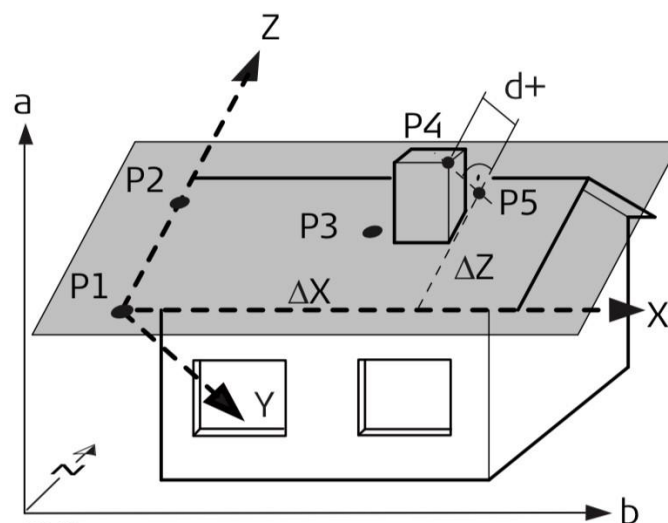

X-axis of local coordinate system.

Y-axis of local coordinate system.

Z-axis of local coordinate system.

P1 First point, origin of local coordinate system.

P2 Second point

P3 Third point

P4 Measured point. This point is probably not located on the plane.

P5 Footprint point of the perpendicular vector from P4 to the defined plane. This point is definitely located on the defined plane. d+ Perpendicular distance from P4 to the plane.

**Functions that can be done by the software buttons:**

[New-tar]: To record and save the intersection point and to proceed to measure a new target point.

[Stakeout]: To display stake out values for the intersection point.

[New-sur]: To define a new reference plane.

[Done]: to go back to the program menu.

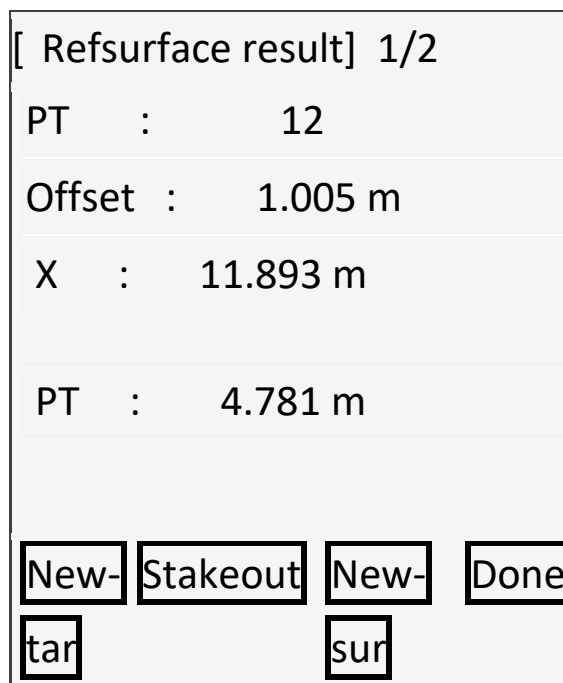

## 6. File manage

File manager contains all functions of input data, edit data and view data.

[Job Manage] 1/2 ▾			
F1 Job (1)			
F2 Fix Pt. (2)			
F3 Meas. PT (3)			
F4 Code (4)			
F1	F2	F3	F4
[Job Manage] 2/2 ▲			
F1 Mem.stat. (5)			
F1			

### 1. Job

- All kinds of measurement data are saved in the selected job. Such as Fix Pt., Meas. PT and so on.
- The function can new a job, select a job and delete a job.
- The definition of the job contains the inputting of Job's name and Operator.

#### 1.1 Select a Job

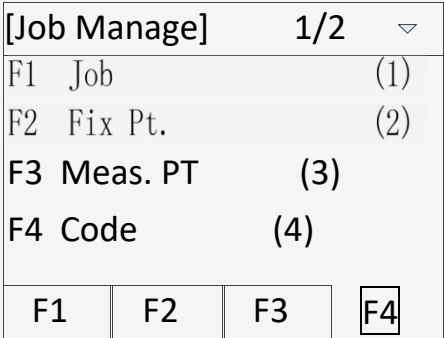
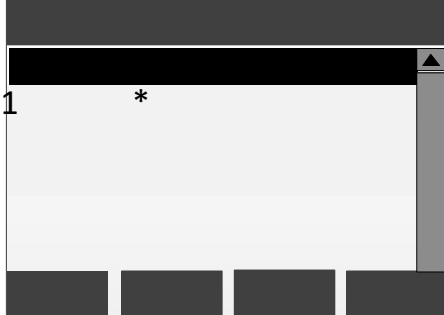
Steps	Key	Display
<p>O1 Press [F1] in the menu of Job Manager to enter menu of job function.</p>	[F1]	
<p>O2 The interface displays the job</p> <p>179</p>	<p>[Job list]</p> <p>JJOBB2 1 *</p>	





list in the current storage. The JOB3 [SD]  
 jobs in the SD card have the mark of JOB4 [SD]  
 “[SD]” and the current job have  
 the mark of “\*”.  New View OK

O3 Using the direction keys to [Job list]

select a job, when the needed job JOB1  
JOB2 \* [↓] JOB3  
 is selected, press the key of [F4],  
[SD ]  
+ JOB4 [SD ]  
 the program gives a prompt of  
[F4]  
 “Job Set” and open the job as the  
 current job.  New View

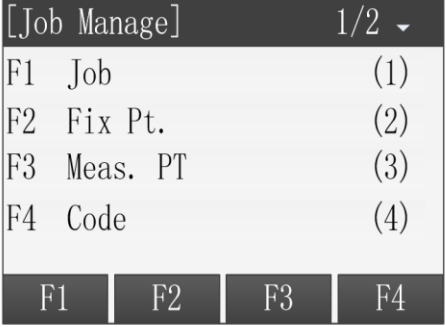
## 1.2 New a Job

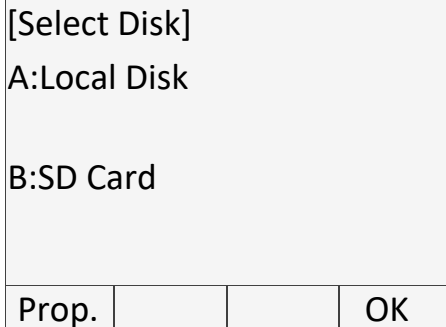
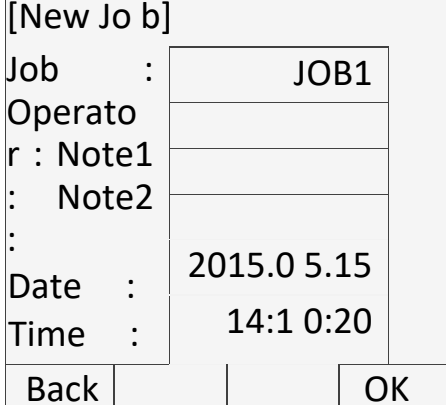
Steps	Key	Display
<p>① In the menu of Job Manager, press [F1] to enter the menu of job function.</p>	[F1]	 <p>[Job Manage] 1/2 ▾            F1 Job (1)            F2 Fix Pt. (2)            F3 Meas. PT (3)            F4 Code (4)            F1   F2   F3   F4</p>
<p>② The interface displays the job list in the current storage. The jobs in the SD card have the mark of “[SD]” and the current job have the mark of “*”. Press [F2] (New) to enter the function of new a job.</p>		 <p>[Job list]            JOB1 *            JOB2            JOB3 [SD]            JOB4 [SD]            Delete   New   View   OK</p>
<p>③ If the instrument has loaded the SD card, there is an interface of Select Disk. In the interface, selecting the disk which is used to new a job by pressing the key of up or down and press [F4] to make sure. A:Local Disk  B:SD Card</p>		 <p>[Select Disk]            A:Local Disk             B:SD Card            Prop.       OK</p>
<p>④ The screen displays the information of new job, including the name of the job, the operator and so on. After inputting one item, press [ENT] to move the cursor to the next input area.”<sup>1</sup></p>	[ENT]	 <p>[New Job]            Job : JOB1            Operator : Note1            : Note2            :            Date : 2015.0 5.15            Time : 14:1 0:20            Back       OK</p>

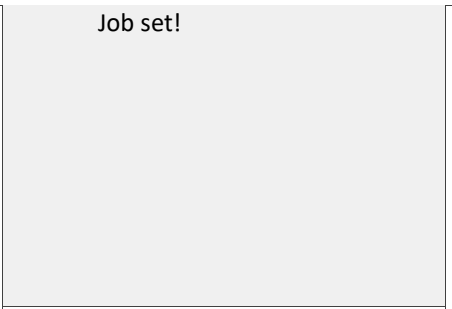
<p>○5 After finishing inputting, press [F4] (OK) to save the job and set it as the current job.</p>	[F4]	
<p>"1: The system creates the data and time automatically.</p>		

[Job]: The name of job inputted arbitrarily by the operator and saving data to the file after this.

[Operator]: The name of operator and it can have the default value.

[Note1] and [Note2] describe the situation of the project and they can have the default values.

- If the job name you inputted exists, the program will give a prompt that Job exists, use another job name.

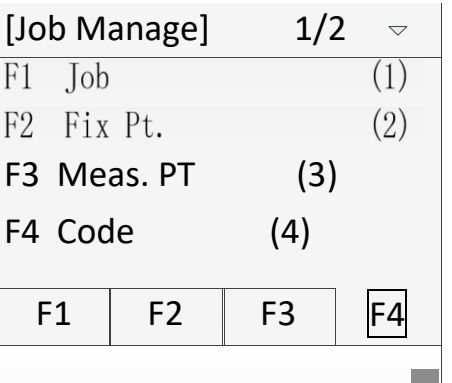
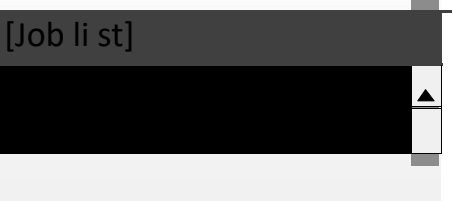

### 1.3 Delete a job

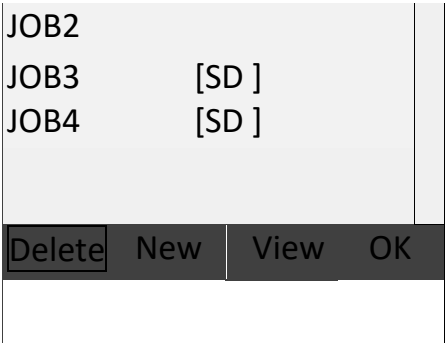
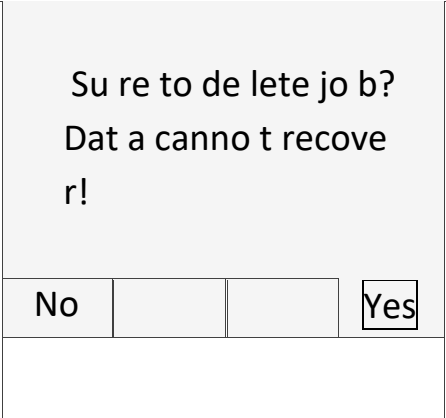
Steps	Key	Display
<p>○1 In the menu of Job Manager, press [F1] to enter the menu of job function.</p>	[F1]	
<p>○2 The interface displays the job list in the current storage. The jobs in the SD card have the mark</p>		

<p>of “[SD]” and the current job have the mark of “*”.</p>		
<p>o3 Using the direction key up or down to select the job that need to be deleted. Press [F1] (Delete) and a dialog appears as shown in the picture on the right.</p> <p>If you make sure to delete it, please press [F4] (Yes), otherwise, press [F1] (No) to back to the previous menu.</p> <p>”<sub>1</sub></p>	<p>[↑], [↓] + [F1] + [F4]</p>	
<p>”<sub>1</sub>: The current job can’t be deleted.</p>		

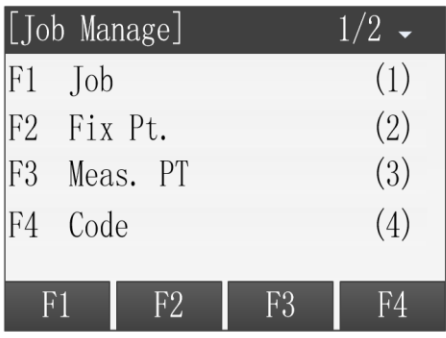
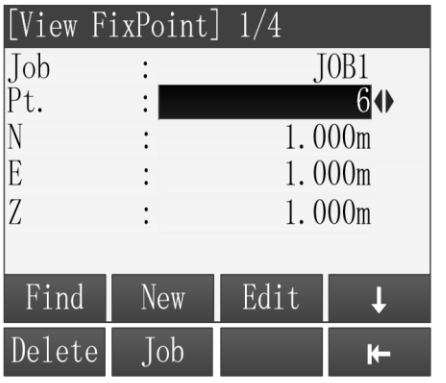

## 2. Fix Pt.

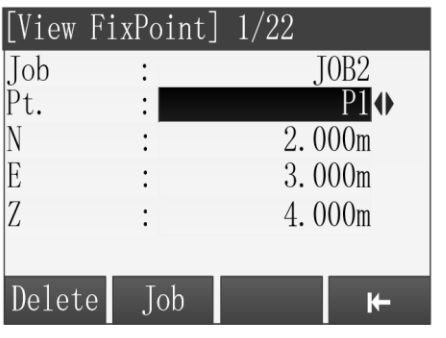
The function can view, edit and delete the fixpoints in all jobs.

Steps	Key	Display
① In the menu of Job Manager, press [F2] to enter the interface of Fix Pt. function.	[F2]	 <p>[Job Manage] 1/2 ▾            F1 Job (1)            F2 Fix Pt. (2)            F3 Meas. PT (3)            F4 Code (4)            F1   F2   F3   F4</p>
② The interface displays the fixpoints of the current job. Pressing the direction key of left or right can scan all fixpoints in the job. Press [F4] to switch to the second page' soft key.	[F4] + [F2]	 <p>[View FixPoint] 1/4            Job : JOB1            Pt. : 6            N : 1.000m            E : 1.000m            Z : 1.000m            Find   New   Edit   ↓            Delete   Job   ←</p>
③ Press [F2](Job) to enter the list of job, press the direction key of up or down to select the job which the viewed fixpoints exist, then press [F4] to make sure. ※ <sup>1</sup>	[F4]	 <p>[Job list]            JOB1 *            JOB2            JOB3 [SD]            JOB4 [SD]            Delete   New   View   OK</p>
④ Program displays the data of fixpoints in the corresponding job. Press the direction key of left or right can view all fixpoints in the job.	[←] [→]	 <p>[View FixPoint] 1/22            Job : JOB2            Pt. : P1            N : 2.000m            E : 3.000m            Z : 4.000m            Delete   Job   ←</p>
※ <sup>1</sup> : The selected job is only used to view fixpoints and it will not be set as current job.		

## 2.1 Search Fix Pt.

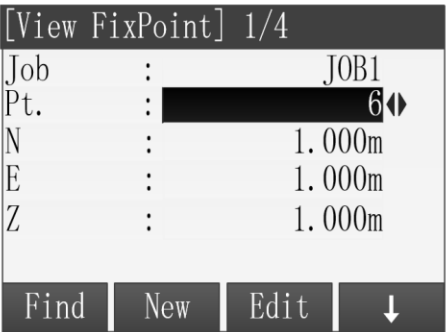
Input the name of point or "\*" to view the fixpoints in the selected job.

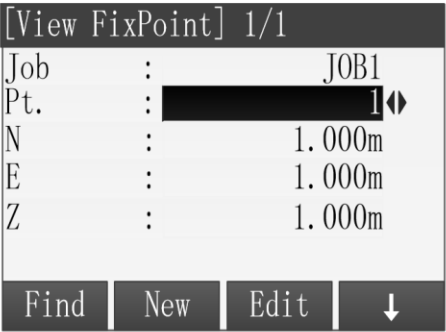
Steps	Key	Display
① In the interface of View FixPoints, pressing [F1] (Find) to enter the function of finding fixpoints.	[F1]	
② There appears a dialog as shown in the picture on the right. Input the name of point or the wildcard of "*", press [ENT] to make sure and press [F4] (OK) to find.	[ENT] + [F4]	
③ Displaying the dialog of finding result. If the point exists in the job, the interface will display the coordinate information of the point. If input the wildcard of "*", you can view all fixpoints by pressing the direction key of left or right.		

## 2.2 Add Fix Pt.

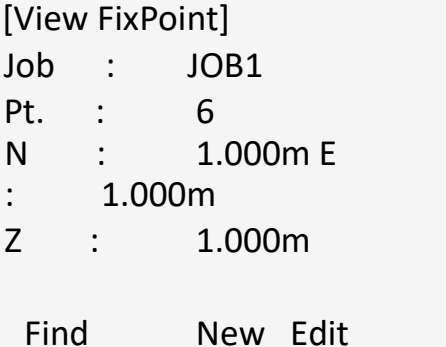
Steps	Key	Display
01 In the interface of View FixPoint, pressing [F2] (New) to enter the function of new fixpoint. If you want to change the job which need to new points, you can press [Job] to select the target job.	[F2]	

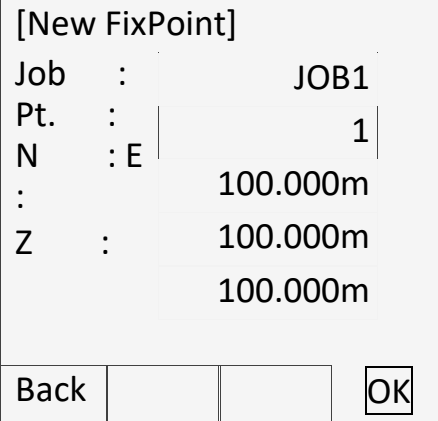
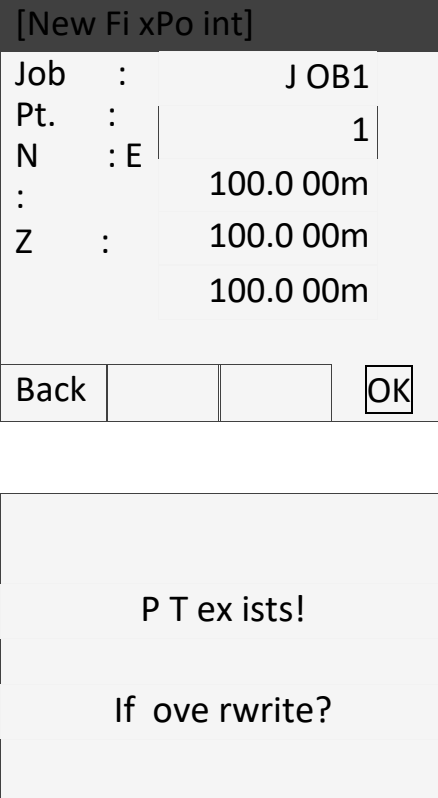
<p>O2 There appears a dialog as shown in the picture on the right. If want to back to the previous menu, you can press [F1] (Back).</p>		
<p>O3 Input the new name and coordinate of fixpoint, press [Ent] to finish inputting and press [F4] (OK) to save the fixpoint.</p> <p>If the inputted point name exists in the memory, the program will give a prompt of whether to overwrite, press [F4](Yes) to overwrite or press [F1](No) to cancel the operation.</p>	<p>[F4]</p>	

		<table border="1"> <tr> <td>No</td> <td></td> <td></td> <td>Yes</td> </tr> </table>	No			Yes																												
No			Yes																															
<p>O4 After finishing new a fixpoint, the program makes the point plus 1 automatically and you can continue to input other fix points, as shown in the picture on the right. Press [F1] (Back) or [ESC] to go back.</p>		<table border="1"> <tr> <td colspan="4">[New Fi xPo int]</td> </tr> <tr> <td>Job</td> <td>:</td> <td colspan="2">J OB1</td> </tr> <tr> <td>Pt.</td> <td>:</td> <td colspan="2">2</td> </tr> <tr> <td>N</td> <td>:</td> <td>E</td> <td></td> </tr> <tr> <td>:</td> <td></td> <td colspan="2">100.0 00m</td> </tr> <tr> <td>Z</td> <td>:</td> <td colspan="2">100.0 00m</td> </tr> <tr> <td></td> <td></td> <td colspan="2">100.0 00m</td> </tr> <tr> <td>Back</td> <td></td> <td></td> <td>OK</td> </tr> </table>	[New Fi xPo int]				Job	:	J OB1		Pt.	:	2		N	:	E		:		100.0 00m		Z	:	100.0 00m				100.0 00m		Back			OK
[New Fi xPo int]																																		
Job	:	J OB1																																
Pt.	:	2																																
N	:	E																																
:		100.0 00m																																
Z	:	100.0 00m																																
		100.0 00m																																
Back			OK																															

### 2.3 Edit Fix Pt.



The function can edit the fixpoints in the memory.

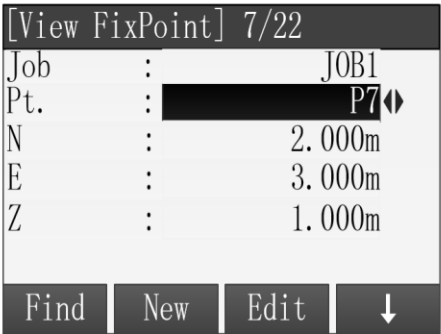
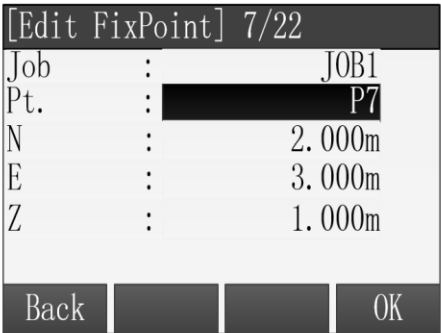
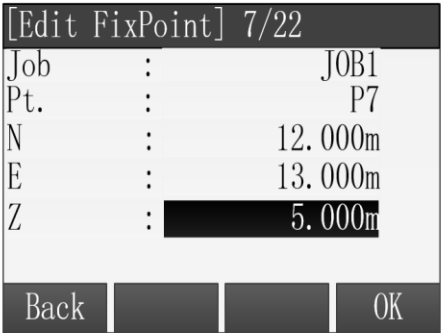

Steps	Key	Display
<p>① In the interface of View FixPoint, you can find the data of need to be edited by pressing the direction key of left or right or in the function of finding. If you want to change the job which the point needs to be edited, you can press [Job] to select the target job.</p>		
<p>② Press [F3] (Edit) to enter the interface of Edit Fixpoint. The screen displays the point data. Input the new point's name and coordinate and press [ENT] to move the cursor to the next row. When the data doesn't need to be edited, you can press [ENT] directly.</p>		
<p>③ Press [F4] (OK) to save the edited data after finishing inputting. Program gives a prompt whether to overwrite or not and press [F4] (OK) to over right and save.</p>	[F4]	

## 2.4 Delete Fix Pt.

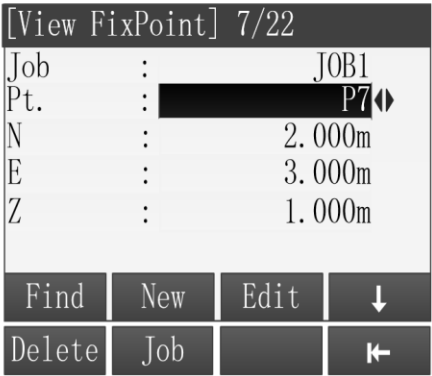
Delete the selected fixpoint from the job.

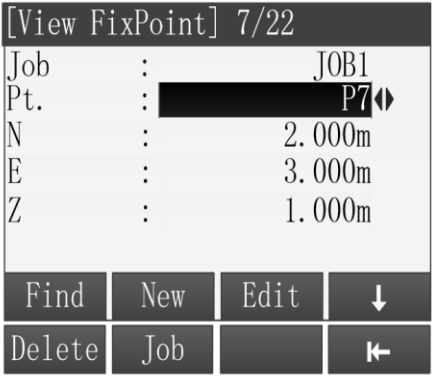
Steps	Key	Display
<p>① In the interface of View FixPoint, you can find the data of need to be deleted by pressing the direction key of left or right or in the function of finding, then press [F4] to switch to the second page of soft key.</p> <p>If you want to change the job which the point needs to be deleted, you can press [Job] to select the target job.</p>	[F4]	
<p>② Press [F1] (Delete) to start the function of deleting data, the interface as shown the dialog on the right. Press [F4] (OK) to delete data and press [F1] (No) to cancel the operation.</p>	[F2]	
<p>③ The interface backs to the previous menu.</p>		

## 3. Meas. Pt.

The measurement data in the job can be searched, displayed, and part of them can be deleted.

### 3.1 View the measurement data

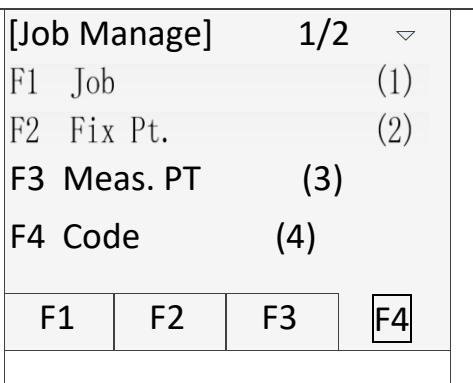
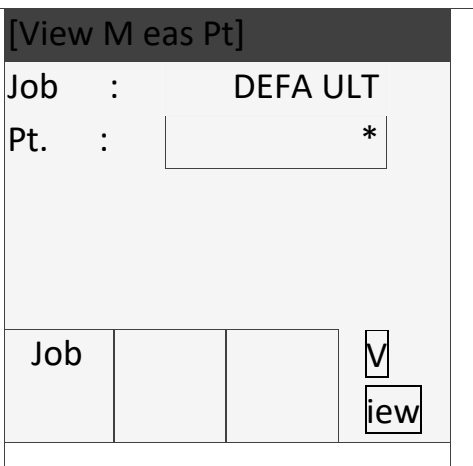
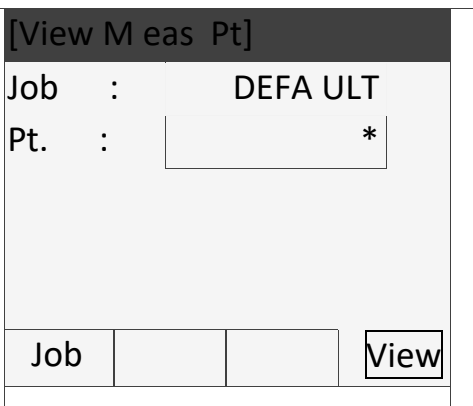
Steps	Key	Display
<p>○1 In the menu of Job Manager, press [F3] to enter the function of Meas.PT.</p>	[F4]	
<p>○2 The default viewed job is the current job in the program, if you want to view the measurement data in other jobs, please press [F1] (Job) to enter the list of job to select.</p>	[F2]	
<p>○3 The default viewed points are all points in the job and using the wildcard character to stand for. If want to view a certain point, you can input the name of the point and press [F4] to view.</p>	[F4]	

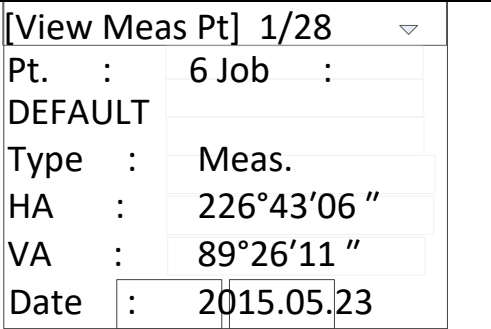
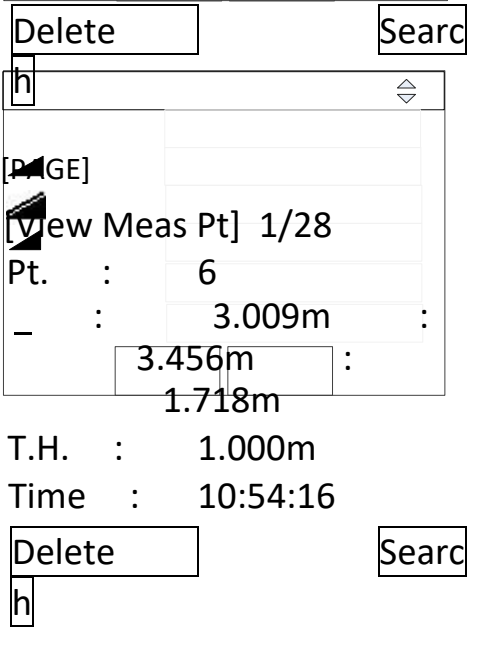
<p>○4 The screen starts to display the information of measurement data from the first piece of data in the job. Press the direction key of left or right can view the measurement point data which match the view condition one by one.</p> <p>Pressing [PAGE] can view a piece of measurement point data' other pages.</p> <p>Press [Search] to back to the interface of View Meas PT.</p>	 
---	--

### 3.2 Delete measurement data

The not good and the repeating measurement data can be deleted.

The station data and the last piece of data in the data items can not be deleted.

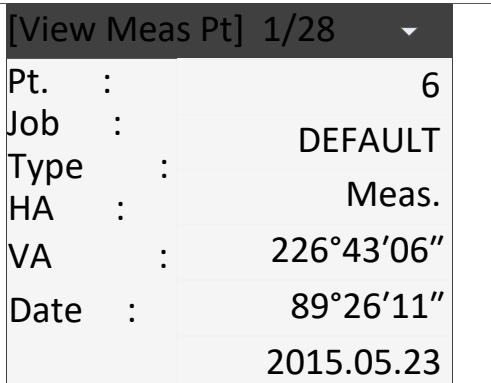
Steps	Key	Display
<p>○1 After finding the measurement point data which need to be deleted, press [F1] to delete.</p>	<p>[F1]</p>	

		<div style="border: 1px solid black; padding: 5px;"> <span>Delete</span> <span style="float: right;"><span>Search</span> h</span> </div>
<p>O2 The window of program prompts whether to delete or not. Press [F4] to make sure to delete and press [F1] to cancel the operation.</p>	[F4]	<div style="border: 1px solid black; padding: 10px; text-align: center;"> <p>If delete data? Da ta cannot recov er!</p> <div style="display: flex; justify-content: space-around; margin-top: 10px;"> <span>No</span> <span>Yes</span> </div> </div>
<p>O3 After the data is deleted, the screen displays the next piece of data.</p>	[F4]	<div style="border: 1px solid black; padding: 5px;"> <p>[View Meas Pt] 1/27  Pt. : 6 Job : DEFAULT  Type : Meas.  HA : 226°43'06 "  VA : 89°26'11 "  Date : 2015.05.23</p> <div style="display: flex; justify-content: space-between; margin-top: 5px;"> <span><span>Delete</span></span> <span><span>Search</span> h</span> </div> </div>

## 4. Code.

Here can make operations on the code library, such as new, finding and deleting.

### 4.1 Input Code

Every code has a note and up to 8 characters attributes.

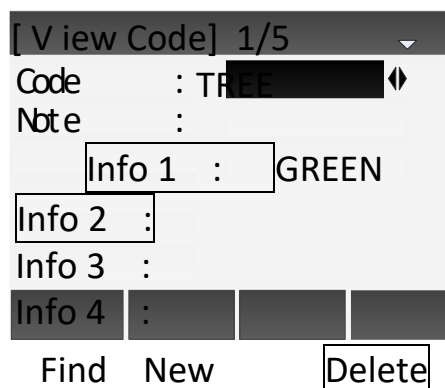

GSI-The introduction of code' attributes:

Code: Name of the code

Note: Additional annotation

Info1: The other editable information

.....

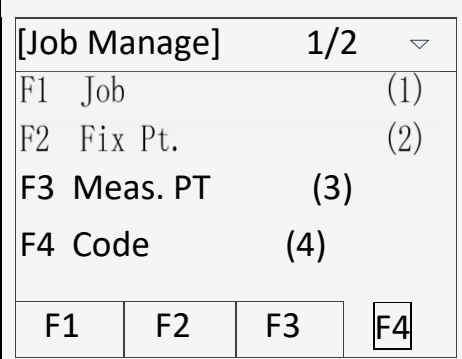

Info8: Other information

Steps	Key	Display
O1 In the menu of Job Manage, pressing [F4] to enter the function of Code.	[F4 ]	

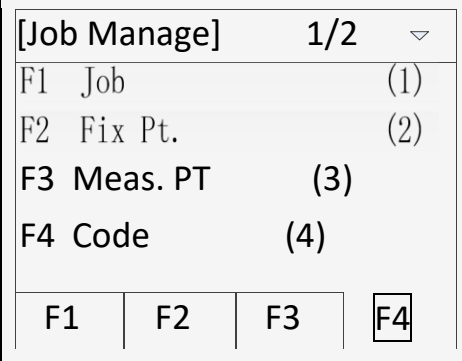
## 4.2 View Code

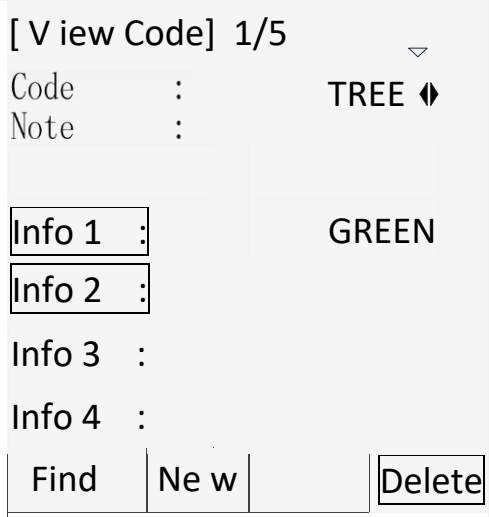
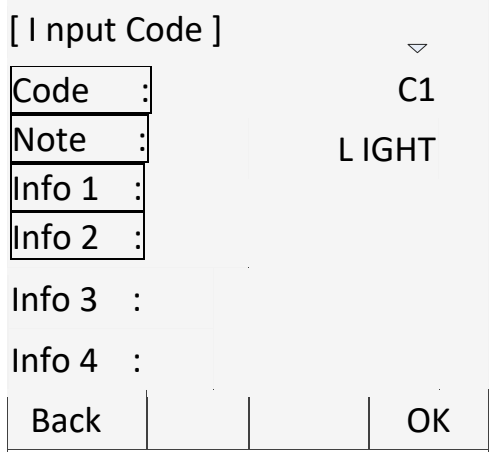
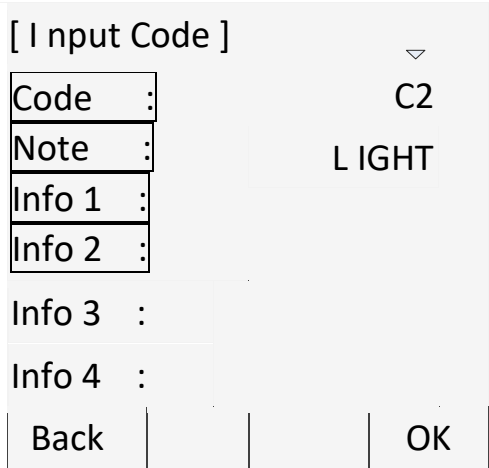
Steps	Key	Display
O1 In the menu of Job Manage, pressing [F4] to enter the function of Code.	[F4 ]	

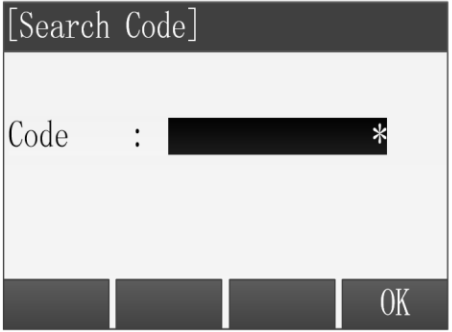
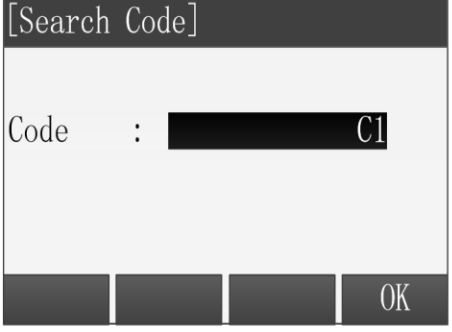
<p>O2 In the interface of View Code, pressing [F2] to enter the function of new code.</p>	<p>[F2]</p>	
<p>O3 Input the name of code and the code information in the interface of Input code.</p>		
<p>O4 After finishing inputting, press [F4] to save the code. Program makes the Code's name plus 1 automatically, and you can continue to input other code. If the inputted code name exists in the memory, the program will give a prompt of whether to overwrite</p>	<p>[F4]</p>	

<p>② Press the direction key of left or right, you can view all codes one by one.</p>		
<p>③ Press [F1] to enter the interface of Search Code. The default value is wildcard character, it stands for all codes.</p>		
<p>④ Input the certain code name and input [F4] to start to search.</p>	<p>[F4]</p>	
<p>⑤ Program displays the searching result, if there are more than one codes matching the searching condition, you can view them one by one by pressing the direction key of left or right. If there is no code matches the condition, the program will give a prompt.</p>		

### 4.3 Delete Code

Steps	Key	Display
-------	-----	---------

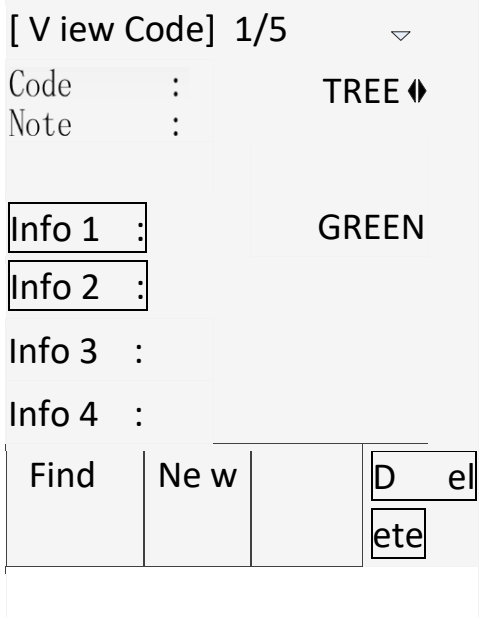
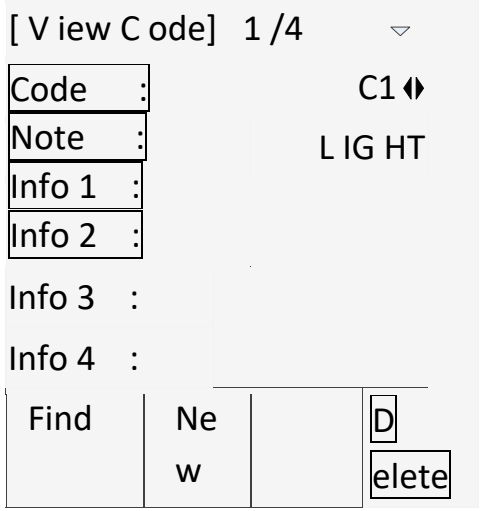
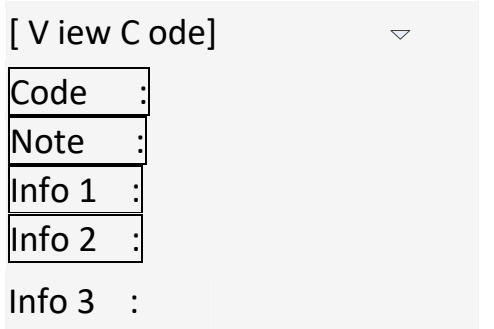

<p>○1 After entering the dialog of code function, press the direction key of left or right to delete the code which need to be deleted.</p> <p>You can also press the key of [Find] to find the corresponding code.</p>		
<p>○2 After finding the code need to be deleted, press [F4] and program will give a prompt whether make sure to delete.</p> <p>A: If the deleted code is find by pressing the direction keys, after the code is deleted, the screen will display the next code.</p> <p>B: If the deleted code which find by press the key of [Find], after the code deleted, the interface displays an empty code, it means that all fields are empty. If there is more than one code matching the finding condition, it will display the next code.</p>	<p>[F4]</p>	<p>A:</p>  <p>B:</p> 

		Info 4 : <input type="text"/> <input type="button" value="Find"/> <input type="button" value="New"/> <input type="button" value="Delete"/>
--	--	---

## 5. Memory Statistics

Display the information of the memory usage and format the memory.

Format the memory can delete all data of job, code and road. The setting of application also can be reset, please operate carefully.

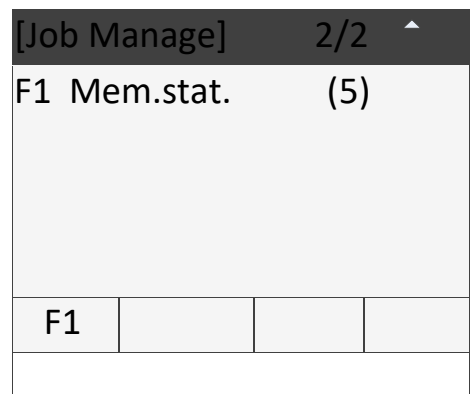
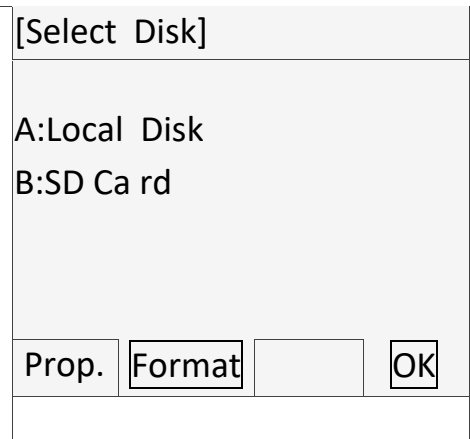
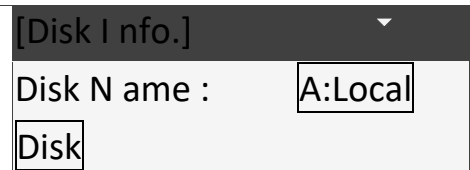
Steps	Key	Display
O1 In the menu of Job Manage, press [PAGE] and display the second page of the menu, press [F1] to enter the function of memory statistics.	[F1]	
O2 Program displays the disk list of the instrument, the default are "A: Local Disk", if instrument has loaded the SD card, it will display the additional disk of " B: SD".		
O3 Press [F1] (Prop.) can view the properties of the disk, including free space.	[F1]	

		<table border="1"> <tr> <td>Disk Sp ace:</td> <td>2 036KB</td> </tr> <tr> <td>Used Sp ace:</td> <td>66KB</td> </tr> <tr> <td>Free Sp ace:</td> <td>1 970KB</td> </tr> <tr> <td><input type="button" value="Format"/></td> <td><input type="button" value="OK"/></td> </tr> </table>	Disk Sp ace:	2 036KB	Used Sp ace:	66KB	Free Sp ace:	1 970KB	<input type="button" value="Format"/>	<input type="button" value="OK"/>
Disk Sp ace:	2 036KB									
Used Sp ace:	66KB									
Free Sp ace:	1 970KB									
<input type="button" value="Format"/>	<input type="button" value="OK"/>									
<p>O4 Press [F2] (Format) can format the disk, program will give a prompt to make sure to format or not, press [F4] to make sure to format and press [F1 to cancel the operation.]</p> <p>"1</p>	<p>[F2]</p>	<table border="1"> <tr> <td colspan="2" style="text-align: center;">Sure to format?</td> </tr> <tr> <td colspan="2" style="text-align: center;">Da ta cannot recov er!</td> </tr> <tr> <td><input type="button" value="No"/></td> <td><input type="button" value="Yes"/></td> </tr> </table>	Sure to format?		Da ta cannot recov er!		<input type="button" value="No"/>	<input type="button" value="Yes"/>		
Sure to format?										
Da ta cannot recov er!										
<input type="button" value="No"/>	<input type="button" value="Yes"/>									
<p>"1: SD card does not support the formatting operation in the instrument.</p>										

## 7. Data Transfer

This function is doing data transmission between instrument and computer, or between instrument and removable device. This function includes 2 parts, import and export.

The data transmission between instrument and removable device must have U Disk plugged in.

**Note:** The machine supports up to 8G U disk read and write, when running the program, don't insert or pull out the U disk. If you pull out the U disk when the instrument checking it, the subsequent operations may cause error!

### 1. Data Import

User can use this function to transfer fixed points data or code data to instrument from computer via RS232 cable. User can also transfer fixed points data to instrument via U Disk.

Import: Fixed Points, Code

Method: RS232, U Disk

Format: CASS, GTS-7, CSV, GSI(For U Disk)

Source: Data file in U Disk (For U Disk)

Job: Target job that data been transfer to.

Steps	Key	Display																				
<p>O1 In main menu, chooses “4 Transfer” to enter “Data Transfer” menu.</p> <p>Pressing [F1] or [1] enters “Import Data”.</p>	[4]	<table border="1"> <tr><td colspan="4">[Transfer]</td></tr> <tr><td>F1</td><td>Import Data</td><td>(1)</td><td></td></tr> <tr><td>F2</td><td>Export Data</td><td>(2)</td><td></td></tr> <tr><td colspan="4"> </td></tr> <tr><td>F1</td><td>F2</td><td></td><td></td></tr> </table>	[Transfer]				F1	Import Data	(1)		F2	Export Data	(2)						F1	F2		
	[Transfer]																					
F1	Import Data	(1)																				
F2	Export Data	(2)																				
F1	F2																					
[F1] or [1]	<table border="1"> <tr><td colspan="4">[Import Data]</td></tr> <tr><td>F1</td><td>Fix Pt.</td><td>(1)</td><td></td></tr> <tr><td>F2</td><td>Cod e</td><td>(2)</td><td></td></tr> <tr><td colspan="4"> </td></tr> <tr><td>F1</td><td>F2</td><td></td><td></td></tr> </table>	[Import Data]				F1	Fix Pt.	(1)		F2	Cod e	(2)						F1	F2			
[Import Data]																						
F1	Fix Pt.	(1)																				
F2	Cod e	(2)																				
F1	F2																					

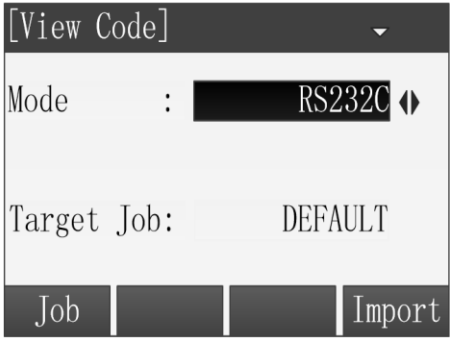
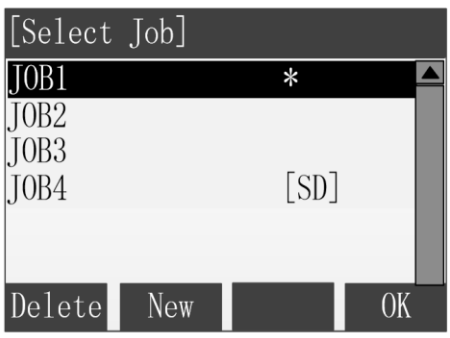
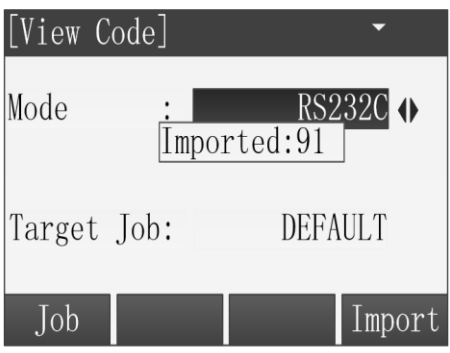
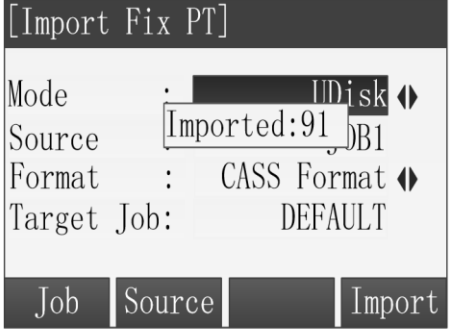
<p>② In “Import Data” menu, press [F1] or [1] entering “Import Fix Pt” window.</p>	<p>[F1] or [1]</p>	
<p>③ Press [F1](Job) to select the job you want transfer data into, then press [F4] (OK).</p>	<p>[F1]  [F4]</p>	
<p>④ If choosing RS232C method, using cable to connect instrument and computer first, on computer side, press button [Send] in transfer software, and then press [F4] (Import) on the instrument.</p>	<p>[F4]</p>	
<p>⑤ If choosing U Disk method, plugging u disk in the instrument usb port first, then:</p> <ol style="list-style-type: none"> <li>1. Press [◀], [▶] key to select “U Disk”;</li> <li>2. Press [F2] to explore files in u disk and select the data file.</li> <li>3. Press [▼], [▲] moving to the format option, then press [◀], [▶] key to select the data file’s format.</li> <li>4. Press [F4] (Import) to start import.</li> </ol>		

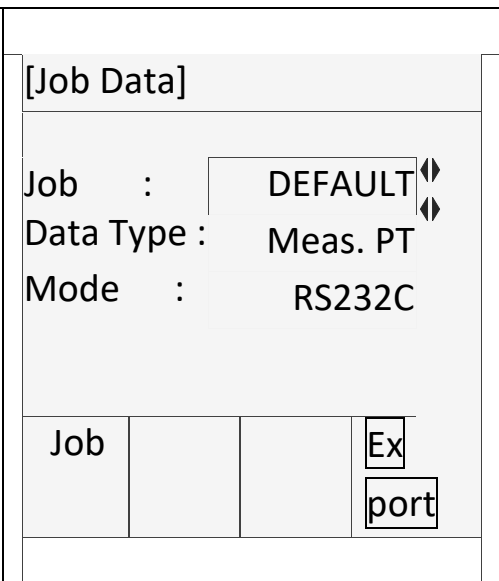
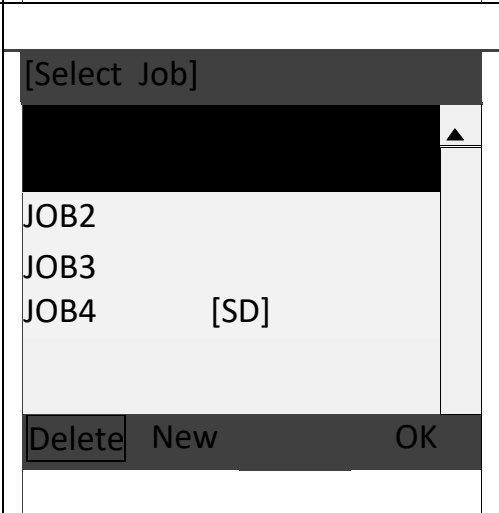
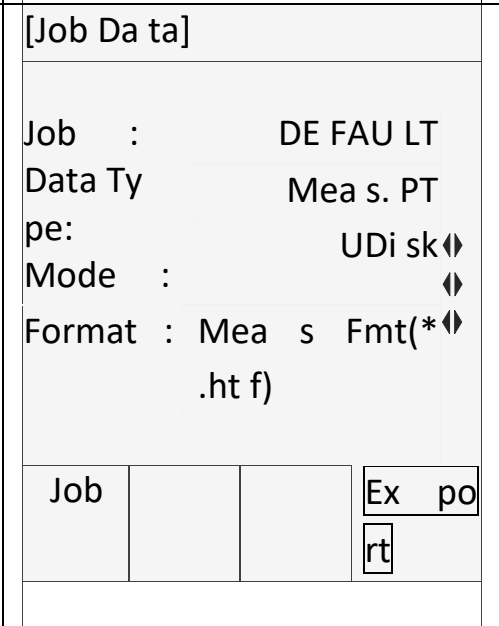
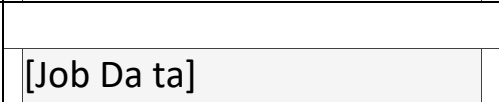

<p>O2 In “Export Data” menu, press [F1] or [1] entering “Export job data” function.</p>	<p>[F1] or [1]</p>	
<p>O3 Press [F1] to select job that you need to export, then press [F4].</p>	<p>[F1]  [F4]</p>	
<p>O4 Press [◀], [▶] key to select data type that you want to export.</p>	<p>[◀]  [▶]</p>	
<p>O5 Two methods to use:</p>	<p>[◀]</p>	

<p>RS232C, U Disk. [▶]</p> <p>Press [◀], [▶] key to select transfer method (mode). [F4]</p> <p>If choosing RS232C, software on the computer should be ready, and then press [F4] to start export.</p> <p>If choosing U Disk, the U Disk should have been plugged in, then press [F4] to start export.</p>	<div data-bbox="850 210 1315 573"> <p>Job : DEF AULT</p> <p>Data Ty pe Meas . PT</p> <p>: Mode : RS 232C</p> <table border="1"> <tr> <td>Job</td> <td></td> <td></td> <td>Export</td> </tr> </table> </div> <div data-bbox="850 618 1315 1133"> <p>[Job Da ta]</p> <p>Job : DE FAULT</p> <p>Data Ty pe: Mea s. PT</p> <p>Mode : UDisk</p> <p>Format : Meas Fmt(*.htf)</p> <table border="1"> <tr> <td>Job</td> <td></td> <td></td> <td>Export</td> </tr> </table> </div>	Job			Export	Job			Export
Job			Export						
Job			Export						

<p>User can also use key [◀], [▶] to select the format of export data.</p> <p>CASS, GTS-7 for fixed points data; HTF, GSI for measure data.</p>	<div data-bbox="850 1498 1315 1901"> <p>[Job Data]</p> <p>Job : DEFAULT</p> <p>Data Type: Meas. PT</p> <p>Mode : UDisk</p> <p>Format : Meas Fmt(*.htf)</p> <table border="1"> <tr> <td>Job</td> <td></td> <td></td> <td>Export</td> </tr> </table> </div>	Job			Export
Job			Export		
	[F4]				



○6 Export code can only use RS232C method. This is same to Step○5 .

[Import Code]

Data Type Code ⬆  
: To : RS 232C

Export

## 8. Instrument Setting

### 1. General Setting

In Setting Menu, choose “1 General” to enter “General Setting”.



Light	:	LOW	Hz increment:	Right	
Trigger Key	:	DIST	V-Setting	:	Zenith
User Key1	:	Level	Angle Unit	:	°" User Key2
NP/P		Min. Reading:			1"
Key Beep	:	On	Dist. Unit	:	Meter Sector Beep : On
Dist.Decimal:		0.0001			
Tilt	:	Off	Temp. Unit	:	
Reset		OK	Reset		OK

Press. Unit	:	hPA
Code	:	Permanent
Auto-Off	:	Off
Port	:	RS232C
Baudrate	:	115200
Coord. type	:	NEZ
Language	:	English
Reset		OK

#### Fields of General Setting

Field	Description
Light	<b>High, Medium, Low, Off.</b> 4 Levels of background light.
Contrast	<b>1~9.</b> Set the display contrast.
Trigger Key	<b>Off:</b> Disable trigger key. <b>ALL:</b> Dist and record. <b>DIST:</b> Only dist.

<b>User Key 1</b>	Configures  1 with a function from the FNC menu.
<b>User Key2</b>	Configures  2 with a function from the FNC menu.
<b>Key Beep</b>	<p>The beep is an acoustic signal after each key stroke.</p> <p><b>On:</b> Enable beep.</p> <p><b>Off:</b> Disable beep.</p>
<b>Sector Beep</b>	<p><b>On:</b> Sector Beep sounds at right angles(0°, 90°, 180°, 270°or 0, 100, 200, 300 gon).</p> <p><b>Off:</b> Sector Beep disabled.</p>
<b>Tilt</b>	<p><b>On:</b> Biaxial compensation enable.</p> <p><b>Off:</b> Tilting compensation disable.</p> <p><b>X Only :</b> Single axis compensation enable.</p>
<b>Hz increment</b>	<p><b>Right:</b> Set horizontal angle to clockwise direction measurement.</p> <p><b>Left:</b> Set horizontal angle to counter-clockwise direction measurement.</p>

## V-Setting

**Zenith:** Zenith =  $0^\circ$ ; Horizon =  $90^\circ$ .

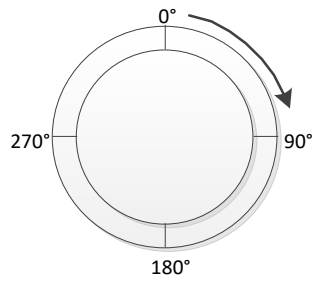

**Horiz.0:** Zenith =  $270^\circ$ ; Horizon =  $0^\circ$ .

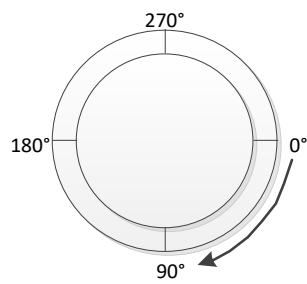

**Vert90:** Zenith =  $90^\circ$ ; Horizon =  $0^\circ$ ;

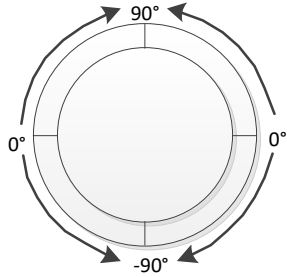
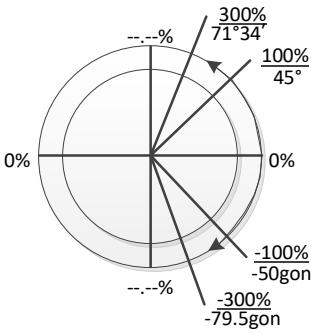
	<p>Positive above horizon, negative below horizon.</p>  <p><b>Slope:</b> Zenith <math>45^\circ=100\%</math>; Horizon = <math>0\%</math>.</p> <p>Positive above horizon, negative below horizon.</p> <p>Exceed 300% shows “---.---%”.</p> 
<p><b>Angle Unit</b></p>	<p>Sets The units shown for all angular fields.</p> <p>° Degree sexagesimal, <math>0^\circ</math> to <math>359^\circ 59' 59''</math>.</p> <p><b>GON</b> Gon, 0 gon to 399.999 gon.</p> <p><b>MIL</b> Mil , 0 to 6399.99mil.</p> <p>The setting of the angle units can be changed at any time. The actual displayed values are converted according to the select unit.</p>

<b>Mini. Reading</b>	<p>Sets the number of decimal places shown for all angular fields. This is for data display and does not apply to data export or storage.</p> <p>°′″:1" /5"/10"</p> <p>Gon:0.0002/ 0.001 / 0.002</p>
	<p>Mil :0.005 / 0.02 / 0.05</p>
<b>Dist. Unit</b>	<p>Sets the units shown for all distance and coordinate related fields.</p> <p><b>Meter</b> Meters [m].</p> <p><b>US-ft</b> US feet [ft].</p> <p><b>INT-ft</b> International feet[fi].</p> <p><b>ft-in1/8</b> US feet-inch-1/8 inch [ft].</p>
<b>Dist. Decimal</b>	<p>Sets the number of decimal places shown for all distance fields. This is for data display and does not apply to data export or storage.</p> <p><b>3</b>Display distance with three decimals.</p> <p><b>4</b>Display distance with four decimals.</p>
<b>Temp. Unit</b>	<p>Sets the units shown for all temperature fields.</p> <p>° Degree Celsius.</p> <p>°F Degree Fahrenheit.</p>
<b>Press. Unit</b>	<p>Sets the units shown for all pressure fields.</p> <p><b>hPA</b> hecto-Pascal.</p> <p><b>mmHg</b> Millimeter mercury.</p> <p><b>inHg</b> Inch mercury.</p>

<b>Code</b>	<p>Sets if the code will be used for one, or many, measurements.</p> <p><b>Rec/Reset</b> The code is cleared after ALL or REC.</p> <p><b>Permanent</b> The code remains after measurements.</p>
<b>Auto-Off</b>	<p><b>30min</b> Auto power off after 30min's no operation.</p> <p><b>Off</b> Disable auto-off.</p>
<b>Port</b>	<p><b>RS232C</b> Use serial port as communication interface.</p> <p><b>Bluetooth</b> Use Bluetooth as communication interface.</p> <p>If instrument does not support Bluetooth, there will be no Bluetooth option here.</p>
<b>Baudrate</b>	<p>Sets the serial port baudrate.</p> <p><b>9600/19200/115200</b></p>
<b>Coord. type</b>	<p>Sets the type of coord.</p> <p><b>NEZ/ENZ</b></p>
<b>Language</b>	<p>Changes the software's interface language.</p>

## 2. EDM Setting

See Chapter "3.2 EDM Setting".

## 9. Adjust and Tools

### 1. Adjust

**Warning :**

The following functions must be carried out under the guidance of professionals, if the operation is wrong, it may lead to the instrument can't work properly!

[Adjust]	2/2
F1 Adjust Tilt Zero	(5)
F1 Const.Setting	(6)
F2 Factory Setting	(7)
F1	F2 F3

below:

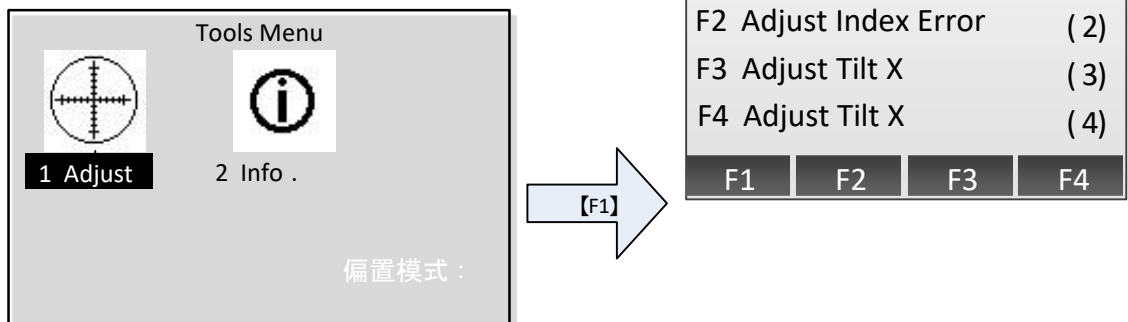

Through Main Menu → “6 Tools” → “1 Adjust”, entering adjust menu, Like

Input PIN code(82543), and then press key ENT, the instrument will be turned off.

[PIN]			
PIN	:	[REDACTED]	
Back			OK

#### 1.1 View adjust parameters

In Tools Menu, choose “1 Adjust”, and then press [F1] to enter “View adjust parameters”.



Parameters include Vert. I.E and tilt sensor parameters.

[View Adjust Param.]	
Vert. I.E.: Xk	93°35 52
:	-0.8400
X0 :	9
Yk :	1.000
Y0 :	0
	OK

## 1.2 Adjust Index Error

In Tools Menu, choose “1 Adjust”, then press [F2] to enter “Adjust Index Error”.

Steps:

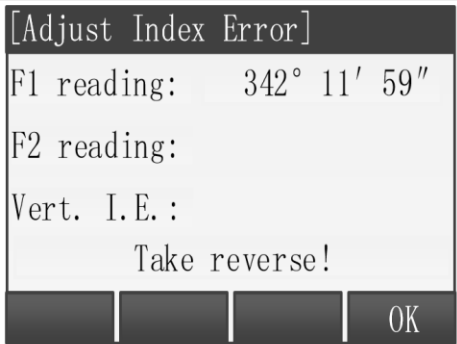
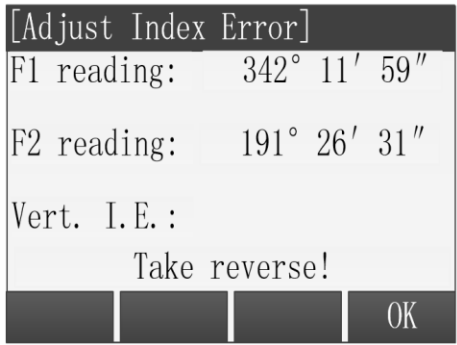
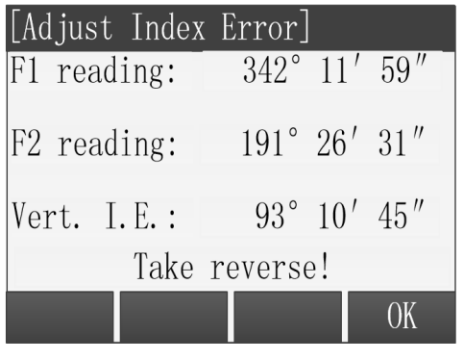
Steps	Key	Display
① After leveling the total station, aim at target with face left, then press [F4](OK).	[F4]	
② Aim at the same target with face right, and press [F4] (OK).	[F4]	
③ Program will show the result value, press [F4](OK) to save.	[F4]	

**Note:** If there is no special requirement, the compensator should be turned on before Index error correction.

## 1.3 Adjust Tilt X

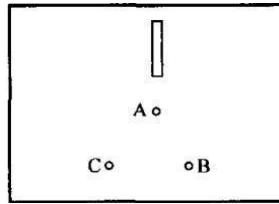

Before compensating for the compensator, make sure that the indicator difference is recalibrated in accordance with 9.1.2 procedure in the closed compensator state.

First, place the instrument as picture shown below with collimator facing up. This will help screw A to adjust the inclination of the instrument.

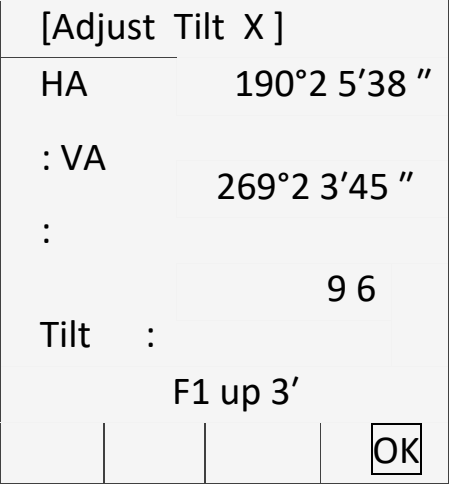

In Tools Menu, choose “1 Adjust”, and then press [F3] to enter “Adjust Tilt X”. These are the calibration of x-direction of compensator’s vertical axis.

Steps	Key	Display
<p>○1 Level instrument, focus on the reticle of collimator, record the vertical angle <math>V_0</math>. Use fine tuning to set vertical angle to <math>V_0+3'</math>, focus on the reticle center accurately, wait for stable value, press [F4](OK).</p>	[F4]	<div style="background-color: #cccccc; padding: 5px; border: 1px solid black;"> <p>[Adjust Tilt X]</p> <p>HA            <math>10^{\circ}12'02''</math></p> <p>:</p> <p>VA    :            <math>81^{\circ}53'50''</math></p> <p>Tilt    :            -117</p> <p style="text-align: center;">F1 up 3'</p> <p style="text-align: right; border: 1px solid black; padding: 2px;">OK</p> </div>
<p>○2 Use fine tuning to set the vertical angle to <math>V_0-3'</math>, focus on the reticle center accurately, wait for stable value, press [F4] (OK).</p>	[F4]	<div style="background-color: #cccccc; padding: 5px; border: 1px solid black;"> <p>[Adjust Tilt X]</p> <p>HA            <math>10^{\circ}12'02''</math></p> <p>:</p> <p>VA    :            <math>81^{\circ}59'50''</math></p> <p>Tilt    :            -86</p> <p style="text-align: center;">F1 do wn 3'</p> <p style="text-align: right; border: 1px solid black; padding: 2px;">OK</p> </div>
<p>○3 Use fine tuning to set the vertical angle as <math>V_0</math>, focus on the reticle center accurately.</p>		



<p>O4 Reverse the telescope, use face right to focus on the reticle of collimator, record the vertical angle V1. Use fine tuning to set the vertical angle as V1-3', focus on the reticle center accurately, wait for stable value, press F4(OK).</p>	<p>[F4]</p>	
<p>⑤ Use fine tuning to set the vertical angle as V1+3', focus on the reticle center accurately, wait for stable value, press [F4](OK).</p>	<p>[F4]</p>	
<p>⑥ After finishing, it will display the results, press [F4](OK), save and back to menu.</p>	<p>[F4]</p>	

**Note:** CoK (linear coefficient): If absolute value > 1.5, you need to re-calibrate; In the correction process by pressing the ESC key, will exit, holding compensator parameters unchanged.

## 1.4 Adjust Tilt Y

In Tools Menu, choose “1 Adjust”, and then press [F4] to enter “Adjust Tilt Y”.

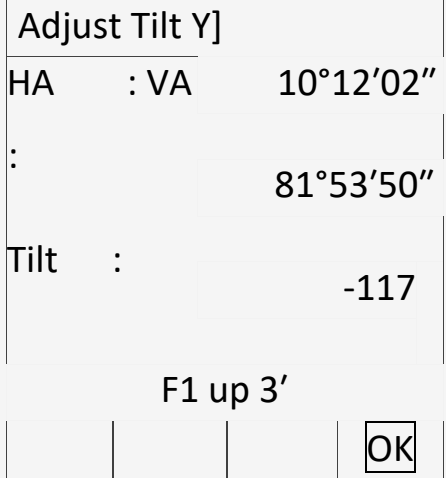
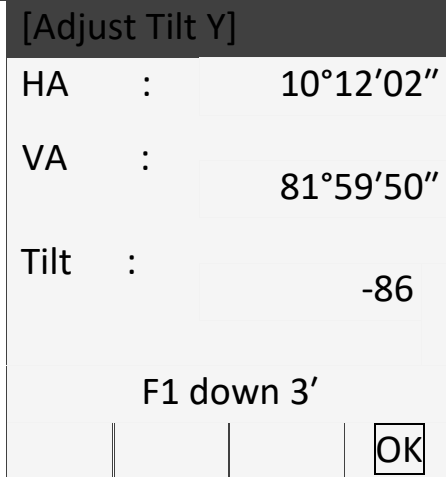
These are the calibration of y-direction of compensator’s vertical axis.

Steps	Key	Display
<p>O1 Level instrument, focus on the reticle of collimator, record the vertical angle V0. Use fine tuning to set vertical angle to V0+3', focus on the reticle center accurately, then turn the instrument counterclockwise 90°, wait for stable value, press [F4](OK), and then turn 90° clockwise back to the original direction.</p>	<p>[F4]</p>	 <p>The screenshot shows the 'Adjust Tilt Y' menu with the following values: HA : VA 10°12'02", VA : 81°53'50", and Tilt : -117. At the bottom, it displays 'F1 up 3'' and an 'OK' button.</p>
<p>O2 Use fine tuning to set the vertical angle to V0-3', focus on the reticle center accurately, then turn the instrument counterclockwise 90°, wait for stable value, press [F4] (OK), and then turn 90° clockwise back to the original direction.</p>	<p>[F4]</p>	 <p>The screenshot shows the 'Adjust Tilt Y' menu with the following values: HA : VA 10°12'02", VA : 81°59'50", and Tilt : -86. At the bottom, it displays 'F1 down 3'' and an 'OK' button.</p>
<p>O3 Use fine tuning to set the vertical angle as V0, focus on the reticle center accurately.</p>		
<p>O4 Reverse the telescope,</p>	<p>[F4]</p>	 <p>The screenshot shows the beginning of the 'Adjust Tilt Y' menu.</p>

<p>use face right to focus on the reticle of collimator, record the vertical angle V1. Use fine tuning to set the vertical angle as V1-3', focus on the reticle center accurately, then turn the instrument counterclockwise 90°, wait for stable value, press F4(OK), and then turn 90° clockwise back to the original direction.</p>		<table border="1" style="width: 100%; border-collapse: collapse;"> <tr> <td style="width: 15%;">HA</td> <td style="width: 10%;">:</td> <td style="width: 15%;">190°2 5'38 "</td> <td style="width: 10%;"></td> <td style="width: 10%;"></td> <td style="width: 10%;"></td> <td style="width: 10%;"></td> </tr> <tr> <td>VA</td> <td>:</td> <td>269°2 3'45 "</td> <td></td> <td></td> <td></td> <td></td> </tr> <tr> <td>Tilt</td> <td>:</td> <td></td> <td></td> <td>9 6</td> <td></td> <td></td> </tr> <tr> <td colspan="7" style="text-align: center;">F1 up 3'</td> </tr> <tr> <td></td> <td></td> <td></td> <td></td> <td></td> <td></td> <td style="text-align: right; border: 1px solid black;">OK</td> </tr> </table>	HA	:	190°2 5'38 "					VA	:	269°2 3'45 "					Tilt	:			9 6			F1 up 3'													OK														
HA	:	190°2 5'38 "																																																	
VA	:	269°2 3'45 "																																																	
Tilt	:			9 6																																															
F1 up 3'																																																			
						OK																																													
<p>O5 Use fine tuning to set the vertical angle as V1+3', focus on the reticle center accurately, then turn the instrument counterclockwise 90°, wait for stable value, press [F4](OK).</p>	[F4]	<table border="1" style="width: 100%; border-collapse: collapse;"> <tr> <td colspan="7" style="text-align: center;">[Adjust Tilt Y]</td> </tr> <tr> <td>HA</td> <td>:</td> <td>342°1 1'59 "</td> <td></td> <td></td> <td></td> <td></td> </tr> <tr> <td>VA</td> <td>:</td> <td></td> <td></td> <td></td> <td></td> <td></td> </tr> <tr> <td>Tilt</td> <td>:</td> <td>269°2 9'46 "</td> <td></td> <td></td> <td></td> <td></td> </tr> <tr> <td colspan="7" style="text-align: center;">91</td> </tr> <tr> <td colspan="7" style="text-align: center;">F1 down 3'</td> </tr> <tr> <td></td> <td></td> <td></td> <td></td> <td></td> <td></td> <td style="text-align: right; border: 1px solid black;">OK</td> </tr> </table>	[Adjust Tilt Y]							HA	:	342°1 1'59 "					VA	:						Tilt	:	269°2 9'46 "					91							F1 down 3'													OK
[Adjust Tilt Y]																																																			
HA	:	342°1 1'59 "																																																	
VA	:																																																		
Tilt	:	269°2 9'46 "																																																	
91																																																			
F1 down 3'																																																			
						OK																																													
<p>O6 After finishing, it will display the results, press [F4](OK), save and back to menu.</p>	[F4]	<table border="1" style="width: 100%; border-collapse: collapse;"> <tr> <td colspan="7" style="text-align: center;">[Adjust Tilt Y]</td> </tr> <tr> <td>HA</td> <td>:</td> <td>342°11'59"</td> <td></td> <td></td> <td></td> <td></td> </tr> <tr> <td>VA</td> <td>:</td> <td>269°29'46"</td> <td></td> <td></td> <td></td> <td></td> </tr> <tr> <td>Tilt</td> <td>:</td> <td></td> <td></td> <td>100</td> <td></td> <td></td> </tr> <tr> <td colspan="7" style="text-align: center;">Xk: 33.0859 X0: -55</td> </tr> <tr> <td></td> <td></td> <td></td> <td></td> <td></td> <td></td> <td style="text-align: right; border: 1px solid black;">OK</td> </tr> </table>	[Adjust Tilt Y]							HA	:	342°11'59"					VA	:	269°29'46"					Tilt	:			100			Xk: 33.0859 X0: -55													OK							
[Adjust Tilt Y]																																																			
HA	:	342°11'59"																																																	
VA	:	269°29'46"																																																	
Tilt	:			100																																															
Xk: 33.0859 X0: -55																																																			
						OK																																													

**Note:** CoK (linear coefficient): If absolute value > 1.5, you need to re-calibrate; In the correction process by pressing the ESC key, will exit, holding compensator parameters unchanged.

## 1.5 Adjust Tilt Zero

In Tools Menu, choose “1 Adjust”, then press [F4] +[F1] to enter “Adjust Tilt Zero”.

Steps:

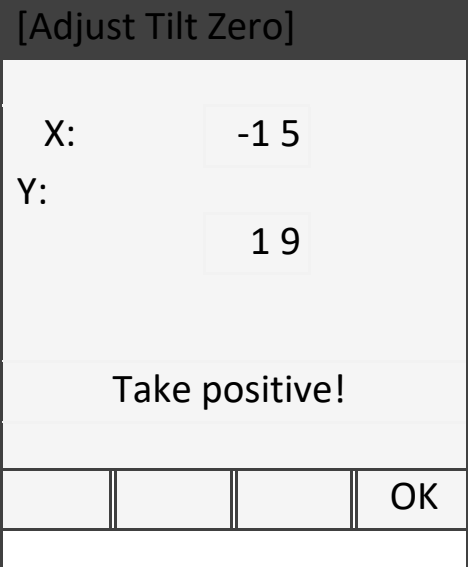
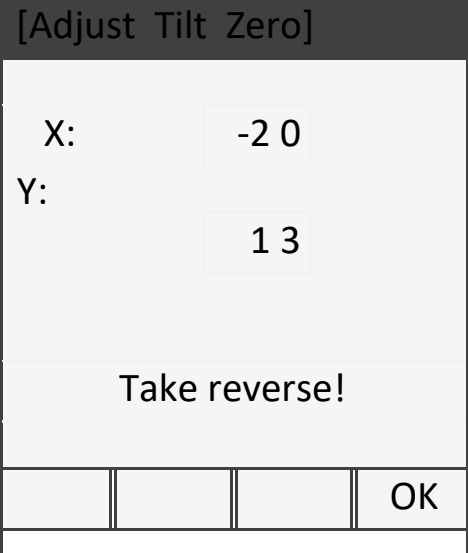
Steps	Key	Display
<p>○1 After leveling the total station, aim at target with face left, then press [F4](OK).</p>	<p>[F4]</p>	 <p>[Adjust Tilt Zero]</p> <p>X: -1 5</p> <p>Y: 1 9</p> <p>Take positive!</p> <p>OK</p>
<p>○2 Aim at the same target with face right, and press [F4] (OK).</p>	<p>[F4]</p>	 <p>[Adjust Tilt Zero]</p> <p>X: -2 0</p> <p>Y: 1 3</p> <p>Take reverse!</p> <p>OK</p>

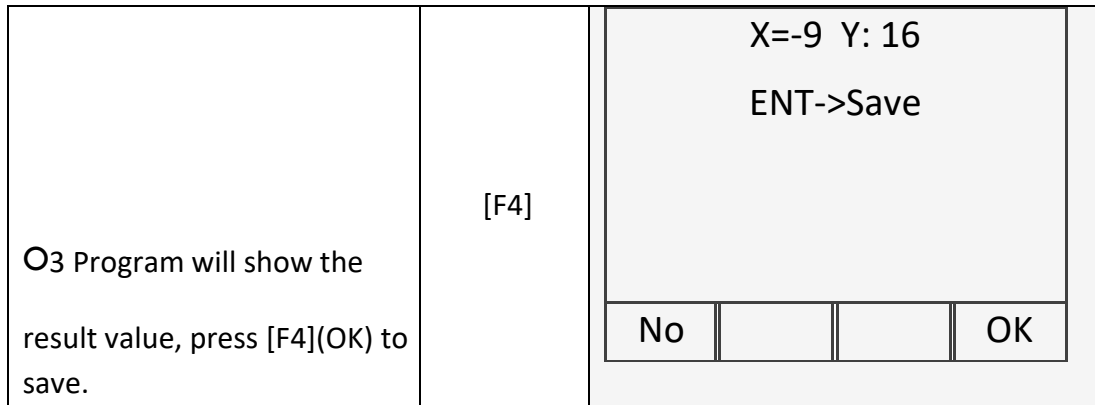

**Note:** If there is no special requirement, the compensator should be turned on before Index error correction.

## 1.6 Instrument constant setting

In Tools Menu, choose “1 Adjust”, and then press [F4] to enter “Const. Setting”. Press [F4](OK) to save after editing the constants.

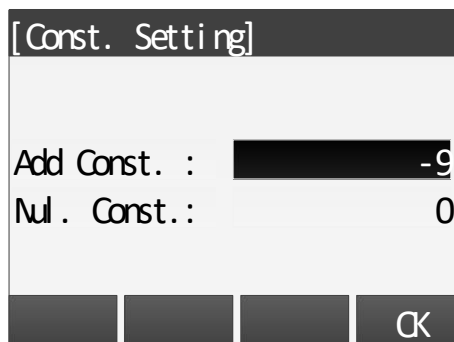

## 1.7 Factory setting

In Tools Menu, choose “1 Adjust”, and then press [5] to enter “Factory Setting”.

If you need to reset the instrument parameters to factory state, you can use this function, press key [F4] (Yes) and then the instrument will auto power off.

## 2. System information

### 2.1 View System Information

In Tools Menu, choose “2 Info.” to enter “Info”.

In this window, user can view detail information about the instrument, includes instrument type and SN, firmware version and date time.



[Info.]			
Inst.No. :	648164		
FW. Ver. :			
Time :	V1.0(20151103)		
Date :	13:42:28		
	2015.11.12		
Date	Time	Upgrade	Back

**System Information**

## 2.2 Set System Date

In system information window, press [F1] (Date) to enter “Date Setting” window.

To set the date, input the new date string that in the format of tips, then press [F4] (OK) to save the new date.

For example: To set date “2015-11-11”, input string “20151111”, then press [F4] (OK) to save.

[Date Setting]			
Date :	2015.11.1 2		
Input as yyyymmdd			
Back			OK

**Date Setting**

## 2.3 Set System Time

In system information window, press [F2] (Time) to enter “Time Setting” window.

To set the time, input the new time string that in the format of tips, then press [F4] (OK) to save the new time.

For example: To set time “13:58:30”, input string “135830”, then press [F4] (OK) to save.

[Time Setting]	
Time(24h):	13:58:30

Input as hhhmss			
Back			OK

Time Setting

## 2.4 Firmware Upgrade

### Warning :

The following functions must be carried out under the guidance of professionals, if the operation is wrong, it may lead to the instrument can't work properly!

This function is prepared for the users to upgrade the instrument software.

1. Input PIN code(82543), and then press key ENT, the instrument will be turned off.

[FW. Upgrade]			
PIN :			
Back			OK

2. Connected to the computer through a serial cable, after installing the correct driver premise, open a HyperTerminal software, configure the correct serial port, it will "bits / sec" is set to 115200, "Data Flow Control" is set to "None" and press

OK.

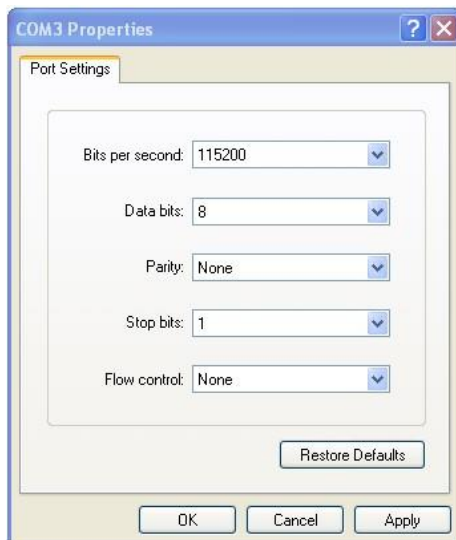

3. Press the power key of the instrument in Hyper Terminal , shown as follows:

**Note:** Software upgrade operation must be careful once you select the instrument into the upgrade status; if press "3" in the picture below, you can also resume running the previous program.

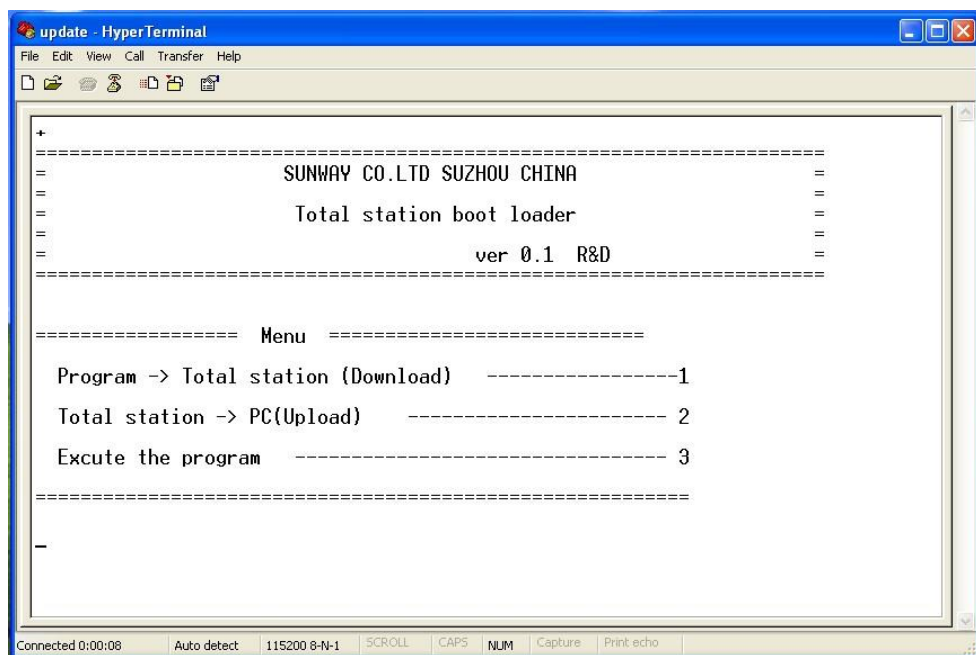

4.

Press 1 button on the keyboard into waiting to send program state, and then select "send file".

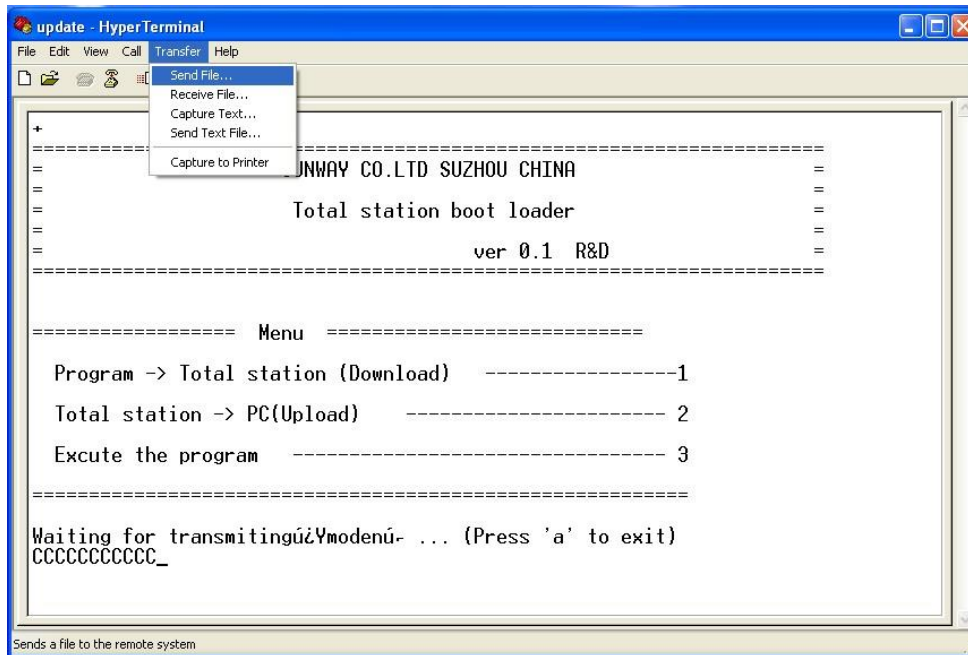

5. Select the new edition total station software, click on "send" button.

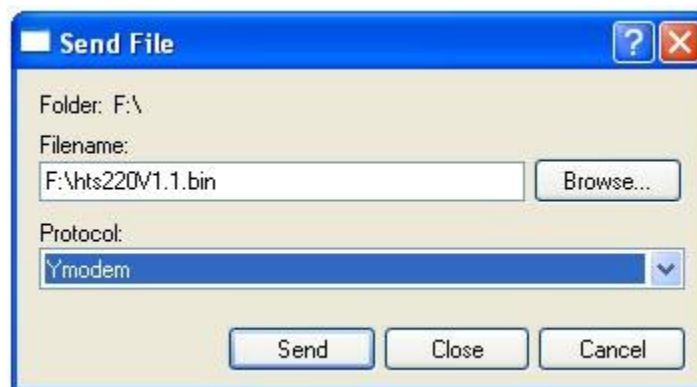

6. It will display the sending application process, and then close the super terminal, starting up after removing the instrument battery and then putting in again. The current software is the new version updated previously.

### 3. Checkout and calibration

The instrument at the factory has to undergo a rigorous inspection and correction, meeting the quality requirements. However, after long transport or environmental change, its internal structure will be some impact. Therefore, the new purchased instruments should be checked and calibrated before surveying to ensure the precision.

### 3.1 Tube level

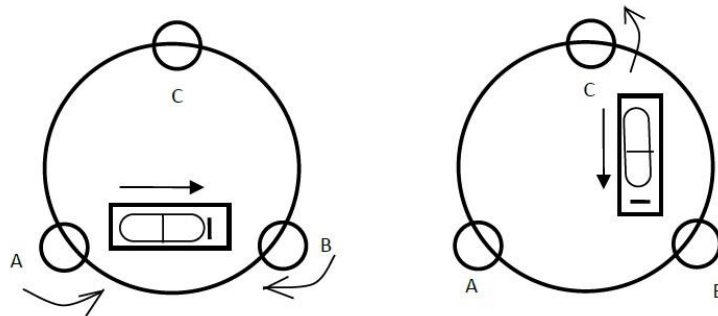

- ◆ **Checkout**

Refer to the chapter "Leveling instrument accurately by tube level" of "Setting up the instrument"

- ◆ **Calibration**

1. In the calibration, if the leveling bulbs diverge from the center, use the foot spiral which parallels the leveling tube to adjust to make the bubble move half of the distance to the center. For the remaining, use the calibration needle to turn the level calibration screw (in the right of the water-level) to adjust the bubble to the center.
2. Turn the instrument for 180 °, check that whether the bubble is in the center. If the bubble is not centered, repeat Step (1) until the bubble to the center.
3. Turn the instrument for 90°, use the third foot screw to adjust the bubble to the center.

- Repeat the Steps of checkout and calibration until the bubble in the center in every direction.

### 3.2 Circular level

- ◆ **Checkout**

After the level tube calibrated correct, if the circular level bubble also in the center, so there is no need to calibrate

- ◆ **Calibration**

If the bubbles is not in the center, use the correction needle or six angle wrench to adjust the correction screw which under the bubble to make the bubble to the center. For calibration, you shall first loosen the calibration screw (1 or 2) which opposite to the direction of the bubble offset, then tighten the other correction screw in the offset direction to make the bubble in the center. When the bubble is in center, make sure the pressures of the three calibration screws are consistent.

### 3.3 Telescope reticle

#### ◆ Checkout

After leveling the instrument find a target A with the telescope, make the center of the crosshair focused on target A and fixed horizontal and vertical brake hand wheel.

1. Rotate telescope vertical micrometer hand wheel, move A point to the edge of the field of view (A 'points).
2. If A moves along the vertical line of the crosshair, but A point is still in the vertical line, as the left picture, the crosshair doesn't need to calibrate. If A point deviate from vertical line center, as the right pictured, the crosshair is slant, so need to calibrate the reticle.

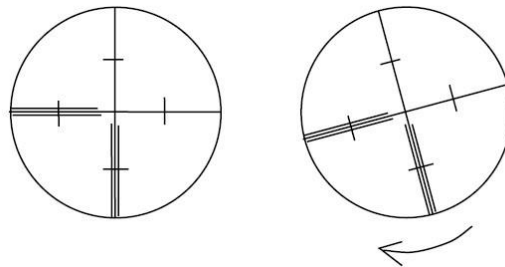

#### ◆ Calibration

1. First, take down the reticle cover between telescope eyepiece and focusing hand wheel, and you can see four fixed screw of the reticle bed (see attached figure).
2. Unscrew the three fixed screw evenly with screwdriver, rotate the reticle around collimation axis, to make A point on the vertical line of the reticle.
3. Tighten the screw evenly, test the calibration results with the above methods.
4. Put the protective cover back.

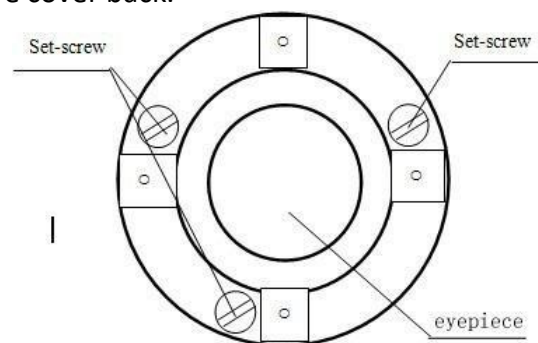

### 3.4 The verticality of collimation axis and horizontal axis(2C)

#### ◆ Checkout

1. Set a target A in about 100m away, and make sure the vertical angle of the target is within  $\pm 3^\circ$ . Precisely level the instrument and switch on it.
2. Make the telescope focused on target A in face left, and read the horizontal angle.

For example: horizontal Angle  $L = 10^{\circ}13'10''$ .

- Loosen the vertical and horizontal brake hand wheel, turn the telescope, rotate the alidade to face right and focus on the same target A. Before aiming please tighten the horizontal and vertical brake hand wheel and read the horizontal angle.

For example: level Angle  $R = 190^{\circ}13'40''$ .

- $2C = L - (R \pm 180^{\circ}) = -30'' \geq \pm 20''$ , need to calibrate.

#### ◆ Calibration

- Use the horizontal micrometer hand wheel to adjust the horizontal angle to the right reading which has eliminated the C.  $R + C = 190^{\circ}13'40'' - 15'' = 190^{\circ}13'25''$
- Take down the reticle bed cover between the telescope eyepieces and focusing hand wheel, adjust the calibration screw of the crosshair on the left and right. First, loosen the screw on one side, and screw up the screw on the other side, move the reticle and focus on target A.
- Repeat the test Steps, calibrate it to  $|2C| < 10''$ .
- Tighten the calibration screws, put the protective cover back.

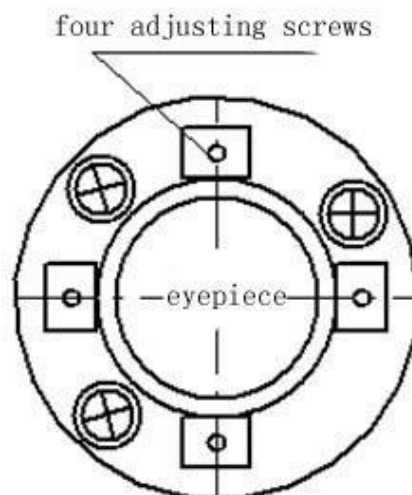

Notice: Check the photoelectric coaxiality after calibrating.

### 3.5 Vertical plate index zero automatic compensation

#### ◆ Checkout

- Set up and level the instrument, make the direction of the telescope consistent with the line between the center of the instrument and any of the foot screw.
- The vertical plate index change to zero after switching on, tighten the vertical brake hand wheel, the instrument display the current telescope vertical angle.

3. Slowly rotate feet X to 10 mm around in one direction, the display of the vertical Angle will change from changing until disappear to appear "compensation beyond!" correspondingly, it indicate that the dip angle of the vertical axis is bigger than 3', beyond the range of vertical plate compensator design. When rotating the feet spiral recovery in the opposite direction, instruments shows vertical Angle again, if you can see the change when testing it again and again in critical positions, it says that vertical plate compensator works normally.

- ◆ **Calibration**

When you find that instrument compensation is useless or abnormal, it should be sent to the factory for checking.

### 3.6 Vertical collimation error (I Angle) and vertical collimation zero value

#### setting

- ◆ **Checkout**

1. Boot after settling and leveling the instrument, focus the telescope on a clear goal A, get the face left reading of vertical Angle L.
2. Turn the telescope to aim A and get the reading R for face right.
3. If the vertical zenith angle is 0°, then  $i = (L + R - 360^\circ) / 2$ , if the vertical Angle level is 0. Then  $i = (L + R - 180^\circ) / 2$  or  $(L + R - 540^\circ) / 2$ .
4. If  $|i| \geq 10''$ , may be you need reset the zero value of vertical index.
5. Operation refers to chapter "Adjust index error".

Note: repeat the checkout steps to retest the index error again (i Angle). If the index error still can not accordance with requirements, it should check the three Steps of calibration index zero setting (in the course of zero setting, the vertical angle showed is not compensated and corrected, it is just for reference) to see whether it is incorrect, whether the focusing of target is correct, reset according to the requirements.

6. If it still can not accordant with the requirements after repeated operation, it should be sent to the factory for checking.

### 3.7 Plummet

- ◆ **Checkout**



1. Set up the instrument to the tripod, draw a cross on a white paper and put it on the ground below the instrument.
2. Adjust the focal length of the optical plummet (for the optical plummet) or switch on laser plummet, move the white paper to make the cross in the center in the field of view (or laser flare).
3. Turn the feet screw, make the center mark of the plummet coincide with the cross center.
4. Rotate alidade, every turn of  $90^\circ$ , observe the contact ratio of the optical plummet and cross center.
5. When rotate the alidade, the center of the optical plummet always coincide with the cross center, there is no need to calibrate. Otherwise you should calibrate as the following methods.

◆ **Calibration**

1. Take down the screw cover between the optical plummet eyepiece and the focusing hand wheel.
2. Fix the white paper with a cross, and mark the points when the instrument rotates  $90^\circ$ , as the figure shows A, B, C, D points.
3. Connect the diagonal points A、C and B、D with a straight line, the intersection name of the two line is O.
4. Use the calibration needle to adjust the four calibration screw, to make the center mark of the plummet coincide with point O.

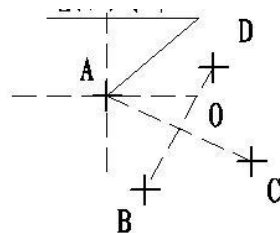

5. Repeat Step 4, check and calibrate until it meet the requirements.
6. With the laser plummet, unbolt the laser cover, using 1 # hex wrench to adjust the three screws, fasten one side and loosen the other side, and adjust the laser flare to point O.
7. Put the cover back in place.

### 3.8 Instrument additive constant (K)

The instrument constant is inspected when it out, and correct it inside the machine, make  $K = 0$ . Instrument constant change rarely, but we suggest that check it this way for one or two times each year. The checkout should be done in the standard baseline, or you can take the following simple method.

#### ◆ Checkout

1. Choose a flat field A to set up and level the instrument , mark three points A、 B、 C in the same line ,their interval is 50m, and set up the reflection prism accurately.
2. After setting the temperature and pressure data, accurately measure the horizontal distance of AB, AC.
3. Setting up and centering the instruments accurately, measure the horizontal distance of BC accurately.
4. You can get the instrument ranging constant:  
$$K = AC - (AB + BC)$$

K should be close to 0, if  $| K | > 5$  mm, it should be send to standard baseline field for strict checking, then calibrate it based on the checking value.

#### ◆ Calibration

If it turns out the instrument constant does not close to 0 but changing after strict inspection, you need to calibrate it, set the instrument additive constant according to the comprehensive constant K value. Such as: the K has been measured as -5 according to the method above, and the original instrument constant is -20,so the new value should be set as  $-20 - (-5) = -15$ ; Input -15 through "menu-> 6-> 3" and then confirm .

- Use the vertical line of the reticle to orientate, make A, B and C at the same line accurately. There must be a clear mark for point B the ground to focus on.
- Whether the prism center of B coincide with the instrument centers is the guarantee of checking the accuracy, so, you had better use tripod and all-purpose tribrach, for example, if you change the three hand type prism connector with tribrach, keep the tripod and tribrach stable, just change the prism and the part above tribrach of instrument, and it can reduce the error of misalignment.

### 3.9 The parallelism of collimation axis and photoelectricity axis

#### ◆ Checkout

1. Set up the reflecting prism 50 meters long from the instrument.
2. Focus on the reflecting prism center with telescope crosshair accurately.

3. Open EDM signal, observe maximum value of the signal, and find the center of the launch axis.
4. Check whether the telescope crosshair center coincide with the emission photoelectricity axis center, if they coincide on the whole we can say it qualified. ♦

#### **Calibration**

If the telescope crosshair center deviates from emission photoelectricity axis center largely, send it to professional repair and calibration department.

### **3.10 No prism ranging**

The red laser beam is coaxial with the telescope, used for no prism ranging, and it is sent by telescope. If the instrument has been calibrated, red laser beams will coincide with the line of sight. External influence such as the vibration, the larger temperature change and other factors may make laser beam and viewing not overlap.

- Before precise ranging, you should check whether the direction of the laser beam is coaxial. Otherwise, it could lead to inaccuracy.

#### **Warning:**

Looking straightly at the laser is dangerous.

#### **Prevention:**

Don't look laser beams directly, or focus on others.

#### ♦ **Checkout**

Put the gray side of the reflector towards the instrument, and put it 5 meters and 20 meters away. Start laser direction function. Focus on the reflector center by the telescope crosshair center, and then check the position of the red laser point. Generally speaking, the telescope is equipped with special filter, human eyes can't see laser point through the telescope, you can see the offset between the red laser point and the reflector crosshair center, you can observe this above the telescope or at the side face of reflector . If laser center coincide with the crosshair center, it indicate that the adjustment meet required accuracy. If the offset between the points position and the mark of crosshair is out of limitless, it need to send it to professional department for adjustment.

## 10. Technical parameters

Function		Unit	Configuration	
Telescope	Imaging	—	Erect	
	Magnification	×	30	
	Field of view	—	1° 20'	
	Min.target distance	m	1.5	
	Effective aperture	mm	40/50(EDM)	
Angle measurement (Hz, V)	2C index error	(")	1.4	
	Angle i index error	(")	2.0	
	Angle measurement method	—	Absolute encoder	
	Minimum reading	(")	1	
Distance measurement (IR)	Range	Single prism	km	3
		Triple prism	km	5
		No- prism <sup>1</sup>	m	400/600/800
	Time	Repeated	s	0.8s
		Tracking	s	0.4
	Minimum display		mm	0.1
	Accuracy	Prism	mm	$\pm(2+2\times 10^{-6}D)$
No- prism		$\pm(3+2\times 10^{-6}D)$		
Tilt compensator	Compensation method	—	Biaxial type	
	Compensation range	(')	$\pm 3$	
Communication Port		—	RS232C	
U disk interface		—	Yes	
Bluetooth		—	Yes	
Temperature and pressure sensor		—	Yes	
SD card		—	Yes	

Display	Screen	—	Both sides (280*160, Black and white screen)
	Illumination	—	Support
Laser Plumb	Laser (optional) Laser Plumb	—	Wavelength 635nm Maximum output power (adjustable): not less than 0.4 m W, not more than 1.0 m W
Level	Tubular level	( " ) /2 mm	30
	Round level	( ' ) /2 mm	8
Built-in application		—	Support
Battery supply	Type	—	Rechargeable High-energy lithium battery
	Voltage	V	7.4
	Power	W	< 2.2
	Battery capacity	mAh	3000
	Working duration	Angle	h
Dist+Angle		h	8 (At + 20 ° C, constant measuring mode)

1: Refers to good weather conditions (visibility is not less than 30km), the goal of KODAK CAT NO.E1527795 (90% of reflecting surface)

## 11. Attachment B File format introduction

These following example to instruct exported file format:

```

STAST001,1.205,AD
XYZ 100.000,100.000,10.000
BKB BS001,45.2526,50.0000
BS BS001,1.800
HVD98.2354,90.2314,10.235
SC A1,1.800,CODE1
NEZ 104.662,99.567,10.214
SD A2,1.800,CODE1

```

HVD 78.3628,92.4612,4.751

SA A3,1.800,CODE1

HV 63.2349,89.2547

NOTE this note

The first record consists of two lines:

The information of first line: record type, name, elevation, code Such as:

STA refers to test site

BKB refers to back sight Angle data

BS refers to back sight

SC refers to coordinate data

SD refers to distance measurement data

SA refers to Angle measurement data

The second line information: data types, data records Such as:

NEZ refers that the following data are coordinates

ENZ refers that the following data are coordinates

HVD refers that the following data are horizontal Angle and vertical Angle and slope distance

HV refers that the following data are horizontal Angle and vertical Angle